

Encyclopedia of  
Language and Education  
*Series Editor: Stephen May*

SPRINGER  
REFERENCE

Kendall A. King · Yi-Ju Lai  
Stephen May *Editors*

# Research Methods in Language and Education

*Third Edition*

 Springer

---

# Encyclopedia of Language and Education

**Series Editor**

Stephen May

Faculty of Education and Social Work

The University of Auckland

Auckland, New Zealand

In this third, fully revised edition, the 10 volume *Encyclopedia of Language and Education* offers the newest developments, including an entirely new volume of research and scholarly content, essential to the field of language teaching and learning in the age of globalization. In the selection of topics and contributors, the Encyclopedia reflects the depth of disciplinary knowledge, breadth of interdisciplinary perspective, and diversity of sociogeographic experience in the language and education field. Throughout, there is an inclusion of contributions from non-English speaking and non-Western parts of the world, providing truly global coverage. Furthermore, the authors have sought to integrate these voices fully into the whole, rather than as special cases or international perspectives in separate sections. The Encyclopedia is a necessary reference set for every university and college library in the world that serves a faculty or school of education, as well as being highly relevant to the fields of applied and socio-linguistics. The publication of this work charts the further deepening and broadening of the field of language and education since the publication of the first edition of the Encyclopedia in 1997 and the second edition in 2008.

More information about this series at <http://www.springer.com/series/15111>

---

Kendall A. King • Yi-Ju Lai • Stephen May  
Editors

# Research Methods in Language and Education

Third Edition

With 10 Figures and 1 Table

 Springer

*Editors*

Kendall A. King  
University of Minnesota  
Minneapolis, MN, USA

Yi-Ju Lai  
University of Minnesota  
Minneapolis, MN, USA

Stephen May  
Faculty of Education and Social Work  
The University of Auckland  
Auckland, New Zealand

ISBN 978-3-319-02248-2                      ISBN 978-3-319-02249-9 (eBook)  
ISBN 978-3-319-02250-5 (print and electronic bundle)  
DOI 10.1007/978-3-319-02249-9

Library of Congress Control Number: 2017936663

©1st edition: © Kluwer Academic Publishers 1997

©2nd edition: © Springer Science+Business Media LLC 2008

©Springer International Publishing AG 2017

This work is subject to copyright. All rights are reserved by the Publisher, whether the whole or part of the material is concerned, specifically the rights of translation, reprinting, reuse of illustrations, recitation, broadcasting, reproduction on microfilms or in any other physical way, and transmission or information storage and retrieval, electronic adaptation, computer software, or by similar or dissimilar methodology now known or hereafter developed.

The use of general descriptive names, registered names, trademarks, service marks, etc. in this publication does not imply, even in the absence of a specific statement, that such names are exempt from the relevant protective laws and regulations and therefore free for general use.

The publisher, the authors and the editors are safe to assume that the advice and information in this book are believed to be true and accurate at the date of publication. Neither the publisher nor the authors or the editors give a warranty, express or implied, with respect to the material contained herein or for any errors or omissions that may have been made. The publisher remains neutral with regard to jurisdictional claims in published maps and institutional affiliations.

Printed on acid-free paper

This Springer imprint is published by Springer Nature  
The registered company is Springer International Publishing AG  
The registered company address is: Gewerbestrasse 11, 6330 Cham, Switzerland

---

## Editor in Chief's Introduction to the "Encyclopedia of Language and Education"

This is one of ten volumes of the *Encyclopedia of Language and Education* published by Springer. The *Encyclopedia* – now in this, its third edition – is undoubtedly the benchmark reference text in its field. It was first published in 1997 under the general editorship of the late David Corson and comprised eight volumes, each focused on a single, substantive topic in language and education. These included: language policy and political issues in education; literacy; oral discourse and education; second language education; bilingual education; knowledge about language; language testing and assessment; and research methods in language and education.

In his introductory remarks, David made the case for the timeliness of an overarching, state-of-the-art review of the language and education field. He argued that the publication of the *Encyclopedia* reflected both the internationalism and interdisciplinarity of those engaged in the academic analysis of language and education, confirmed the maturity and cohesion of the field, and highlighted the significance of the questions addressed within its remit. Contributors across the first edition's eight volumes came from every continent and from over 40 countries. This perhaps explains the subsequent impact and reach of that first edition – although no one (except, perhaps, the publisher!) quite predicted its extent. The *Encyclopedia* was awarded a Choice Outstanding Academic Title Award by the American Library Association and was read widely by scholars and students alike around the globe.

In 2008, the second edition of the *Encyclopedia* was published under the general editorship of Nancy Hornberger. It grew to ten volumes as Nancy continued to build upon the reach and influence of the *Encyclopedia*. A particular priority in the second edition was the continued expansion of contributing scholars from contexts outside of English-speaking and/or developed contexts, as well as the more effective thematic integration of their regional concerns across the *Encyclopedia* as a whole. The second edition also foregrounded key developments in the language and education field over the previous decade, introducing two new volumes on language socialization and language ecology.

This third edition continues both the legacy and significance of the previous editions of the *Encyclopedia*. A further decade on, it consolidates, reflects, and expands (upon) the key issues in the field of language education. As with its predecessors, it overviews in substantive contributions of approximately 5000

words each, the historical development, current developments and challenges, and future directions, of a wide range of topics in language and education. The geographical focus and location of its authors, all chosen as experts in their respective topic areas, also continues to expand, as the *Encyclopedia* aims to provide the most representative international overview of the field to date.

To this end, some additional changes have been made. The emergence over the last decade of "superdiversity" as a topic of major concern in sociolinguistics, applied linguistics, and language education is now a major thread across all volumes – exploring the implications for language and education of rapidly changing processes of migration and transmigration in this late capitalist, globalized world. This interest in superdiversity foregrounds the burgeoning and rapidly complexifying uses of language(s), along with their concomitant deconstruction and (re)modification, across the globe, particularly (but not exclusively) in large urban environments. The allied emergence of multilingualism as an essential area of study – challenging the long-held normative ascendancy of monolingualism in relation to language acquisition, use, teaching, and learning – is similarly highlighted throughout all ten volumes, as are their pedagogical consequences (most notably, perhaps, in relation to translanguaging). This "multilingual turn" is reflected, in particular, in changes in title to two existing volumes: *Bilingual and Multilingual Education* and *Language Awareness, Bilingualism and Multilingualism* (previously, *Bilingual Education* and *Language Awareness*, respectively).

As for the composition of the volumes, while ten volumes remain overall, the *Language Ecology* volume in the second edition was not included in the current edition, although many of its chapter contributions have been reincorporated and/or reworked across other volumes, particularly in light of the more recent developments in superdiversity and multilingualism, as just outlined. (And, of course, the important contribution of the *Language Ecology* volume, with Angela Creese and the late Peter Martin as principal editors, remains available as part of the second edition.) Instead, this current edition has included a new volume on *Language, Education and Technology*, with Steven Thorne as principal editor. While widely discussed across the various volumes in the second edition, the prominence and rapidity of developments over the last decade in academic discussions that address technology, new media, virtual environments, and multimodality, along with their wider social and educational implications, simply demanded a dedicated volume.

And speaking of multimodality, a new, essential feature of the current edition of the *Encyclopedia* is its multiplatform format. You can access individual chapters from any volume electronically, you can read individual volumes electronically and/or in print, and, of course, for libraries, the ten volumes of the *Encyclopedia* still constitute an indispensable overarching electronic and/or print resource.

As you might expect, bringing together ten volumes and over 325 individual chapter contributions has been a monumental task, which began for me at least in 2013 when, at Nancy Hornberger's invitation, Springer first approached me about the Editor-in-Chief role. All that has been accomplished since would simply not have occurred, however, without support from a range of key sources. First, to Nancy Hornberger, who, having somehow convinced me to take on the role, graciously

agreed to be Consulting Editor for the third edition of the *Encyclopedia*, providing advice, guidance, and review support throughout.

The international and interdisciplinary strengths of the *Encyclopedia* continue to be foregrounded in the wider topic and review expertise of its editorial advisory board, with several members having had direct associations with previous editions of the *Encyclopedia* in various capacities. My thanks to Suresh Canagarajah, William Cope, Viv Edwards, Rainer Enrique Hamel, Eli Hinkel, Francis Hult, Nkonko Kamwangamalu, Gregory Kamwendo, Claire Kramersch, Constant Leung, Li Wei, Luis Enrique Lopez, Marilyn Martin-Jones, Bonny Norton, Tope Omoniyi, Alastair Pennycook, Bernard Spolsky, Lionel Wee, and Jane Zuengler for their academic and collegial support here.

The role of volume editor is, of course, a central one in shaping, updating, revising, and, in some cases, resituating specific topic areas. The third edition of the *Encyclopedia* is a mix of existing volume editors from the previous edition (Cenoz, Duff, King, Shohamy, Street, Van Deusen-Scholl), new principal volume editors (García, Kim, Lin, McCarty, Thorne, Wortham), and new coeditors (Lai, Or). As principal editor of *Language Policy and Political Issues in Education*, Teresa McCarty brings to the volume her long-standing interests in language policy, language education, and linguistic anthropology, arising from her work in Native American language education and Indigenous education internationally. For *Literacies and Language Education*, Brian Street brings a background in social and cultural anthropology, and critical literacy, drawing on his work in Britain, Iran, and around the globe. As principal editors of *Discourse and Education*, Stanton Wortham has research expertise in discourse analysis, linguistic anthropology, identity and learning, narrative self-construction, and the new Latino diaspora, while Deoksoon Kim's research has focused on language learning and literacy education, and instructional technology in second language learning and teacher education. For *Second and Foreign Language Education*, Nelleke Van Deusen-Scholl has academic interests in linguistics and sociolinguistics and has worked primarily in the Netherlands and the United States. As principal editors of *Bilingual and Multilingual Education*, Ofelia García and Angel Lin bring to the volume their internationally recognized expertise in bilingual and multilingual education, including their pioneering contributions to translanguaging, along with their own work in North America and Southeast Asia. Jasone Cenoz and Durk Gorter, principal editors of *Language Awareness, Bilingualism and Multilingualism*, bring to their volume their international expertise in language awareness, bilingual and multilingual education, linguistic landscape, and translanguaging, along with their work in the Basque Country and the Netherlands. Principal editor of *Language Testing and Assessment*, Elana Shohamy, is an applied linguist with interests in critical language policy, language testing and measurement, and linguistic landscape research, with her own work focused primarily on Israel and the United States. For *Language Socialization*, Patricia Duff has interests in applied linguistics and sociolinguistics and has worked primarily in North America, East Asia, and Central Europe. For *Language, Education and Technology*, Steven Thorne's research interests include second language acquisition, new media and online gaming environments, and



theoretical and empirical investigations of language, interactivity, and development, with his work focused primarily in the United States and Europe. And for *Research Methods in Language and Education*, principal editor, Kendall King, has research interests in sociolinguistics and educational linguistics, particularly with respect to Indigenous language education, with work in Ecuador, Sweden, and the United States. Finally, as Editor-in-Chief, I bring my interdisciplinary background in the sociology of language, sociolinguistics, applied linguistics, and educational linguistics, with particular interests in language policy, Indigenous language education, and bilingual education, along with my own work in New Zealand, North America, and the UK/Europe.

In addition to the above, my thanks go to Yi-Ju Lai, coeditor with Kendall King, and Iair Or, coeditor with Elana Shohamy. Also to Lincoln Dam, who as Editorial Assistant was an essential support to me as Editor-in-Chief and who worked closely with volume editors and Springer staff throughout the process to ensure both its timeliness and its smooth functioning (at least, to the degree possible, given the complexities involved in this multiyear project). And, of course, my thanks too to the approximately 400 chapter contributors, who have provided the substantive content across the ten volumes of the *Encyclopedia* and who hail from every continent in the world and from over 50 countries.

What this all indicates is that the *Encyclopedia* is, without doubt, not only a major academic endeavor, dependent on the academic expertise and goodwill of all its contributors, but also still demonstrably at the cutting edge of developments in the field of language and education. It is an essential reference for every university and college library around the world that serves a faculty or school of education and is an important allied reference for those working in applied linguistics and sociolinguistics. The *Encyclopedia* also continues to aim to speak to a prospective readership that is avowedly multinational and to do so as unambiguously as possible. Its ten volumes highlight its comprehensiveness, while the individual volumes provide the discrete, in-depth analysis necessary for exploring specific topic areas. These state-of-the-art volumes also thus offer highly authoritative course textbooks in the areas suggested by their titles.

This third edition of the *Encyclopedia of Language and Education* continues to showcase the central role of language as both vehicle and mediator of educational processes, along with the pedagogical implications therein. This is all the more important, given the rapid demographic and technological changes we face in this increasingly globalized world and, inevitably, by extension, in education. But the cutting-edge contributions within this *Encyclopedia* also, crucially, always situate these developments within their historical context, providing a necessary *diachronic* analytical framework with which to examine *critically* the language and education field. Maintaining this sense of historicity and critical reflexivity, while embracing the latest developments in our field, is indeed precisely what sets this *Encyclopedia* apart.

---

# Volume Editors' Introduction to "Research Methods in Language and Education"

---

## Introduction

Research methods in language education have blossomed, diversified, and matured in the decades between the first edition of the *Encyclopedia of Language and Education*, published in 1997, and this third edition. This maturation is evident in the development of increasingly sophisticated theoretical approaches as well as the adoption and refinement of specialized data collection and analysis techniques, both of which are described in this volume in great detail in its 39 timely chapters, organized into four sections.

Evident in this volume, but also apparent more broadly throughout the *Encyclopedia* as well as across the field, are the ways the study of language and education has benefited from sustained and serious discussions of research methodology (e.g., Blom and Unsworth 2010; Gass 2015; Mackey and Gass 2012; Polio 2014). A dominant, although not always productive strand in many discussions of methodology has been the debate about quantitative vs. qualitative methods, sometimes characterized as a division between more cognitive and more social approaches to studying language and education in general and second language (L2) learning in particular (King and Mackey 2016). Indeed, a great deal of ink has been spent on the relative merits and limitations of supposedly dichotomous paradigms and their respective approaches and methods, a tension which characterized many social science fields and applied linguistics throughout the 1990s (e.g., Beretta et al. 1994; Firth and Wagner 1997; van Lier 1994) as well as more recently (e.g., Gregg 2006; Watson-Gegeo 2004).

As the field increasingly grapples with methodologically sophisticated ways in an attempt to address a growing number of urgent, real-world problems in language education, we are pleased to note that contemporary conversations now take a more open, productive, and conciliatory tenor on both sides (see King and Mackey 2016, for extended discussion). Researchers of all stripes have come to (near) agreement that there is "no single, monolithic social-cognitive gap in L2 learning and teaching research" (Hulstijn et al. 2014, p. 414). As DeKeyser (2014) argued in *Studies in Second Language Acquisition*, "the quantitative-qualitative distinction does not belong here at all. Counter-examples abound of the cognitive equals quantitative

and social equals qualitative equations" (p. 366). This more open, collaborative, cross-fertilization approach is evident in the chapters of this volume as well.

Echoing a parallel perspective, albeit from a slightly different vantage point, the distinction between the so-called "micro" (that is, individual) and "macro" (group) language and education processes has been widely discussed and in more recent years, critiqued. Like the first edition, coedited by Nancy H. Hornberger and David Corson (1997), and the second edition (King 2008), this volume of the *Encyclopedia* is organized into four sections following Hornberger's (1989) quadrant typology (see also McKay and Hornberger 1996).<sup>1</sup> Within this typology, the two axes are defined by micro/macro-linguistic and micro/macro-social levels of analysis, yielding four quadrants. These axes reflect research in language and education that emphasizes the linguistic, the social, and perspectives running the gamut from macro- to micro-levels of analysis. With respect to social context, for example, one might be concerned with the (macro) national level (e.g., state language policy), the (micro) face-to-face interactional level, or with the level of domains or communities of practice, which bridge macro to micro. With respect to linguistic issues, questions might revolve around learners' choice of one language or another (so-called macro), use of a particular phonological variant (so-called micro), or around the intermediary levels of discourse, which bridge macro to micro (McKay and Hornberger 1996).

As Hornberger observed in her introduction to the first edition of this volume (Hornberger and Corson 1997), an important assumption of this typology is that perspectives that bridge micro- to macro-understandings, as well as societal and linguistic analyses, are crucial to understanding most language and education processes. Put differently, in order to gain a complete picture of, for instance, language learning in immersion classrooms, we need not only so-called "macro-level" understanding of the development of supporting national and local language education policy but also fine-grained, so-called "micro-level" analyses of teacher–student and student–student interactional patterns in this context. Another example: in order to fully understand the classroom role of minority language varieties such as African-American English in the USA, we need not only micro-linguistic level, variationist analysis of how different English varieties are employed in classroom contexts, but also broader, macro-language-and-societal level analyses of language contact over time, including language ideologies and policies.

The importance of these connections across so-called "micro" and "macro" processes has been taken up by numerous scholars over the last decade. One line of work has critiqued this "micro"/"macro" distinction. Warriner (2012), for

---

<sup>1</sup>While the numbering of the quadrants 2 and 3 varies across Hornberger and Corson (1989) and King (2008), the notion of four broad areas of scholarship is consistent: macro-social and macro-linguistic; macro-social and micro-linguistic; micro-social and macro-linguistic; and micro-linguistic and micro-social. The typology usefully highlights varied levels of analytical focus with respect to the context examined (e.g., a piece of text or discourse, a speech event, small group conversation, classroom, community, society, and nation) and language features studied (e.g., one phoneme vs. choice of language).

instance, argued that these "terms are often used as if their meanings are self-evident and also as if the relationship between them is well-theorized and well understood" (p. 173). She notes that there is relatively "little awareness that the terms themselves profoundly shape what counts as data (and knowledge), how such data are analyzed, and what the consequences might be for theorizing and investigating language, learning, and identity" (p. 173).

Others have sought to develop theoretical and methodological tools to bridge what is increasingly seen as a problematic and unproductive dichotomy between micro and macro. Some analysts have suggested reframing this distinction with the classic constructs of "agency" and "structure." The notion of "agency" provides a means to account for change over time and the emergence of new or unexpected behaviors; in turn, consideration of "structure" captures the powerful constraints at work in all language learning contexts. However, as Wortham (2012) notes, this reframing does not satisfactorily resolve the core problem of "where exactly does such structure reside?" (p. 130). Indeed, "just as microanalysts too often explain their core insight about emergence with reference to one homogeneous factor like 'agency' or interactional creativity, however, macroanalysts too often explain their core insight about constraint with reference to 'structure'" (p. 130). As Wortham and others have noted, "a narrow focus on micro or macro, agency or structure will thus fail to explain many phenomena" within both the anthropology of education as well as second language (L2) learning (p. 131).

In response to this challenge, a number of alternatives have been proposed and/or applied to the field of language and education, including "practice theory" (Ortner 2006), "timescale" approaches (Lemke 2002), and nexus analysis (Scollon and Scollon 2004), many of which are addressed in this present volume. Warriner (2012), building on Hornberger's suggestion (1989), notes that these two sets of factors – micro and macro – cannot be taken as opposites but rather argues that it is more "productive to think of them collectively as a set of mutually beneficial resources" (p. 173). A related approach has been suggested by Lemke (2000), who argues that human semiotic processes are characterized by interdependence among processes at widely varying timescales (cf. Archer 1995; Layder 1997). Collins (2012) adopts this approach in his analysis of family and school language learning among Indigenous Mexican immigrants in New York. His close, ethnographically informed description highlights the ways in which processes happening at a global scale (e.g., migration, increasing stratification of economic and social capital) constrain local events (e.g., use of Spanish in public spaces and signs), often reproducing and intensifying inequality. As Wortham (2012) notes, this work "does not posit 'macro' scales as naturally and eternally central to all social processes. Instead, [Collins] relates large-scale processes to the more local scales that they are mediated through" (p. 135). As detailed below, while the basic organizational structure of this volume remains intact across the three editions, these insights are reflected both in updates to original chapters and in the inclusion of new chapters.

## Volume Organization and New Developments

This volume provides readers with an overview of the wide range of methodological approaches to language and education across multiple vantage points, as well as the multiple connections between and across them. To this end, each of the four sections focuses on a particular subarea of language and education research methods: "Language, Society and Education" in Sect. 1; "Language Variation, Acquisition and Education" in Sect. 2; "Language, Culture, Discourse and Education" in Sect. 3; and "Language, Interaction and Education" in Sect. 4. While the structure of the volume is unchanged from previous editions, there are updates and additions throughout, including 19 newly commissioned chapters that reflect developments in the field as well as our evolving world and contexts of research. In the fields of language and education, the need for studying increasingly complex, interconnected, and rapidly changing research contexts has, at least in part, driven the development of new and better research approaches.

Perhaps the most notable approach, and certainly one of the most cited, is the field's attempt to grapple – conceptually, methodologically, and analytically – with what has been termed "superdiversity." Since the concept of superdiversity was introduced a little over a decade ago (Vertovec 2005, 2007), it has been taken up by a wide range of fields, including law, economics, social work, urban planning, linguistics, and education, among many others (e.g., see King and Bigelow, in press; Nathan 2011; Valentine 2013). Within the fields of language education, and sociolinguistics in particular, superdiversity has gained traction and has corresponded with the growing emphasis on understanding how multilingual practices intersect with the intertwined processes of transnationalism, globalization, and digital media spread (e.g., Canagarajah 2013; Duff 2015).

As the term has gained wider currency, it has often been invoked, somewhat one dimensionally, as a descriptive adjective, a synonym for "hyper" or "extreme" diversity, and taken to mean (even) more ethnic groups or more categories of minoritization or difference. For this reason, it is productive to return to the three, interrelated dimensions of the construct as initially introduced (Vertovec 2007). The first and most widely applied aspect is descriptive. The term superdiversity was coined to describe the changing populations resulting from shifting global migration flows over roughly the last three decades. These changes entail not only the movement of people from increasingly varied backgrounds (i.e., national, ethnic, linguistic, religious, educational) but also varied migration channels (e.g., student migration, undocumented workers, family reunion). Superdiversity was proposed as a descriptive summary term, meant "to encapsulate a range of such changing variables surrounding migration patterns– and, significantly, their interlinkages– which amount to a recognition of complexities that supersede previous patterns and perceptions of migration-driven diversity" (Meissner and Vertovec 2015, p. 542). This shift is apparent here both in the revisions to "old" chapters (e.g., Lado and Sanz's greater emphasis on multilingualism) and in the addition of new ones (e.g., Li Wei and García's chapter on researching translanguaging and Park's on researching the globalization of English).

The second and less often invoked component of superdiversity is theoretical and methodological, as recognition of these shifts and indeed the "new normal" of unpredictable, wide-spread migratory flows calls into question many long-standing assumptions, terms, and categories (e.g., trajectories of assimilation, culture, speech community, code-switching) and underlines the need to develop new theoretical and methodological approaches to describe and explain present conditions. This dimension has coincided with greater emphasis across the social sciences as well as within applied linguistics on cross-disciplinary methods, including transnational ethnography and multimodal communication, among other fields, many of which are represented in the present volume (e.g., Allard's chapter on timescales, Rowsell and Collier's review on studying multimodality, and de Saint-George's chapter on researching media and multilingualism). As Meissner and Vertovec (2015) note, superdiversity is a theoretical and conceptual work in progress and many core issues remain unresolved. At a methodological level, a superdiversity lens draws attention to the need for the field of language and education to develop new theoretical and methodological approaches to describe and explain current conditions. Methodologically, superdiversity entails grappling with new research and theoretical approaches that are better equipped to deal with hyper-diverse, fluid, and unpredictable contexts in which transnational flows and migrations are the norm rather than the exception.

The third and final component of superdiversity, and arguably the least considered to date, is practical and policy oriented. Here the construct pushes actors, including educators and policymakers, to consider the conditions, challenges, and opportunities created by these shifting and unpredictable migration flows. As Meissner and Vertovec (2015) observe, superdiversity presents policymakers with serious challenges because policies are often made for the majority or in response to a prototypical issue or idealized person. A major line of research in the last decade has attempted to document how individuals experience, construct, and negotiate language education policy through close analysis of on-the-ground interactions and their attendant ideologies. This work, often referred to as the ethnography of language policy, bridges the so-called "micro" and "macro" perspectives and has developed in part as a response to these shifts and flows (see McCarty and Liu, this volume).

These empirical and conceptual developments are directly or indirectly reflected in the new and updated chapters in this third edition, which emphasizes new and cutting-edge work in language education. In broad terms, this means a greater emphasis on advances in particular ethnographic research approaches (e.g., Mangual Figueroa; Warriner and Anderson); how technology functions as a research tool and target of pressing research questions (e.g., de Saint-George; Pitkänen-Huhta and Pietikäinen; Snyder and Tour; Wan Mansor and Zakaria); and how researchers have targeted and developed newly prominent concepts in language and education, such as social class (Block), body movements and interaction in the classroom (Li), and translanguaging (Li Wei and García).

Section 1, "Language, Society and Education," opens the volume with ten chapters that review current research approaches and methods to investigating language, society, and education with emphasis on both "macro" linguistic and

"macro" social levels of analysis. The first two chapters in this section address the sociology of language and education. Fishman<sup>2</sup> provides a historical perspective on the foundation and development of the sociology of language as a field of research and key methodological tensions and debates within the field over time. Jakar, in turn, emphasizes more recent trends investigating how forces of globalization have shaped the field of the sociology of language as it relates to education. She suggests that future research consider transnational mobility of individuals, goods, and services, along with the diffusion of mass information via telecommunications. Next, Park directs our attention to approaches for studying the globalization of English. He examines both early research methods and recent shifts, from initial focus on the form, function, and ideologies of English to current poststructuralist perspectives on speakers' translingual practices. Park suggests that future research will include interdisciplinary approaches to critically examine the interlinkages between the power of English and sociological variables in the capitalist economy, along with further new areas of investigation in the globalization of English such as language and materiality as well as language and desire.

The following three chapters examine approaches to researching language, education, and policy. Drawing from his research experience with minority language planning on three continents, Spolsky outlines methods to studying language education policy. His chapter reflects his well-known conceptualization of language policy (as consisting of beliefs, practices, and management) and includes discussion of research into the practices of the members of the speech community, on members' beliefs, and into the management of the languages in the speech community. Spolsky argues for the importance of researchers developing their language policies and positions based on empirical data and systematic analysis of that data. Ricento, in his chapter, discusses current research approaches to studying historical perspectives on language, education, and ideologies, focusing on the examination of social hierarchies reflected in and (re)produced through ideologies of language. He emphasizes the importance of approaches such as critical discourse analysis (CDA) in order to closely examine the nature and effects of ideologies on language and education at all levels of society. McCarty and Liu, in turn, direct our attention to the historical development and role of critical ethnographic approaches and sociocultural perspectives in the study of language education, planning, and policy. They advocate for collaboration with local participants to support greater language and social justice in education and to build concrete possibilities for positive change in society.

Section 1 also provides chapters that review research approaches to the study of language and education in diverse educational and societal contexts around the globe. For instance, Huss describes current research approaches to studying language loss and revitalization, focusing on the persistence of minority language

---

<sup>2</sup>Due to his death in 2015, Joshua Fishman's "Theoretical and Historical Perspectives on Researching the Sociology of Language and Education" is reprinted here as it appeared in the second edition of the *Encyclopedia* in 2008. It is the only unrevised chapter in this current volume; his words and framing are still highly relevant and authoritative given its historical focus.

maintenance, ethnic revival movements, and promotion of multilingualism. She highlights some of the specific challenges facing language revitalization researchers. These areas of intensive work include defining successful language revitalization, determining best practices for collaboration across language activists and researchers, and appropriately incorporating technology into revitalization efforts. Next, de Saint-George focuses on the growing body of research addressing the nexus of multilingualism, media, and education. Her chapter traces progressive changes in researching the role of the media in formal and informal language acquisition and the methodological challenges facing researchers studying multilingual practices in/of the media. De Saint-George calls for multi- and/or cross-disciplinary methodologies to most effectively examine the meaning construction, learning in media, and accesses to repertoires. Hornberger further develops this cross-disciplinary theme in her discussion of the continua of a biliteracy model as an ecological framework for researching language education policy, planning, and practice in multilingual settings. She suggests that ongoing and future research on the continua of biliteracy will address constructs embedded in the framework, including translanguaging, the ecology of language, and ideological and implementational spaces. In the last chapter of this section, Leeman examines census and large-scale survey methods in language education studies, emphasizing the ideological and political aspects of survey language question formation and of data collection and analysis. She concludes her chapter with suggestions for future research, including innovative methodologies involving quantification of language use within specific areas.

Section 2, "Language Variation, Acquisition and Education," shifts the focus to a micro-level linguistic perspective (including but not limited to the phonetic, phonological and morphological level) while keeping the macro-level social interaction analysis (across large data bases, speech communities, educational systems, societies, and nations). Chapters in this section examine research approaches in studying language acquisition and linguistic varieties in educational settings. Hazen reviews current variationist approaches targeting language teaching, language learning, and language use in schools. He focuses in particular on how teaching and learning opportunities can be improved through educators' adoption of variationist perspectives. Abbuhl and Mackey examine both qualitative and quantitative approaches to the study of second language acquisition. They highlight three markers of study quality – validity, reliability, and replicability for quantitative research as well as credibility, transferability, and dependability for qualitative research – each of which need to be taken into consideration for high quality research. Lado and Sanz, in turn, review some of the varied research methodologies adopted to answer empirical and theoretical questions within the newly established field of third and additional language acquisition. They suggest a combination of micro, macro, and learner-centered designs to investigate the complex nature of multilingual acquisition and performance. Li Wei reviews a range of diverse research approaches to studying bilingualism and bilingual education, including perspectives of linguistics, psycholinguistics, and sociolinguistics. His review reflects the interdisciplinary nature of the field, highlighting the development of bilingual/multilingual competences and language use by bilingual/multilingual individuals, and framing bilingualism and



multilingualism as socially constructed phenomena and bilingual/multilingual individuals as social actors. Li Wei and García present research approaches to studying translanguaging in education. Their review traces the development of the term from early work in Welsh language revitalization to the current, worldwide translanguaging research. Li Wei and García suggest that future research work include a critical analytical lens that views translanguaging not as discrete but as repertoire that is accessed for specific communicative practices and purposes.

The next three chapters provide a discussion of narrative approaches or mixed methods to investigating language learning and teaching. Rahatzad, Dockrill, and Phillion address narrative approaches to the study of educational issues of social (in)justice and social (in)equity, highlighting the intersections of narrative inquiry and multicultural education, and narrative multiculturalism and cross-cultural inquiry. Melzi and Caspe synthesize early and recent research methodologies used to study developmental trajectories of child narrative competence and the connections between narrative abilities and relevant skills for educational achievement. They highlight the importance of examining the extent to which narrative-based interventions and educators' teaching strategies might improve the educational prospects of children with diverse backgrounds. Varghese and Huang detail research approaches to the study of language teacher education, examining how language teachers learn to teach, how they teach, and how they position themselves as educators and individuals. Varghese and Huang suggest that future research directions might productively use mixed methods to explore multiple teaching practices and their impact on students' achievement as well as critical approaches to more fully understand language teacher identities and language teaching.

Section 2 also includes chapters discussing research approaches and methods in studying sociological factors (e.g., social class, gender, and identity) in language in educational contexts. Block considers studies that use critical research approaches to studying the tight relationships between social class and language in education. He highlights the challenges facing researchers, such as definitions and explanations of class in applied linguistic and sociolinguistic research. Block suggests that future research addresses class-based research on language teaching and learning across educational contexts and around the world. The next two chapters, by Rezaei and Vaish, respectively, delve into research methodologies for studying learner identity among learners with diverse linguistic and cultural backgrounds in language and education. Rezaei provides a detailed review of different research methods used in studies of language and identity, including narrative inquiry, ethnography, interviewing, questionnaire, and diary keeping. Vaish, in turn, focuses on the long-standing concepts in studies of second language acquisition (SLA) and identity, including resistance, investment, and attitudes.

Section 3, "Language, Culture, Discourse and Education," centers on the interconnectedness across language, culture, discourse, and education, taking a macro-level linguistic analysis (e.g., patterns of language use in the context of a speech event or of a discourse) while keeping a micro-level social interaction perspective (e.g., small groups, classrooms, and local communities). Chapters cover anthropological and sociolinguistic approaches to the study of language, cultural, and

discourse practices in different educational contexts. Creese and Copland discuss the still developing field of linguistic ethnography, which traces its roots back to the ethnography of communication, interactional sociolinguistics, the performance of identity and talk, and microethnography. This line of research has evolved on the premise that close analysis of socioculturally situated language use provides foundational insights into the complexities and dynamics of everyday life. Next, Garrett discusses research approaches and methods to study language socialization in and outside the classroom and school, including a review of the four features defining and reflecting the interdisciplinary origins of language socialization as a field of study. He also challenges our current discussion of what the field conceptualizes as "successful" and "failed" outcomes of language socialization. Palmer and Caldas take up critical ethnography, a method and theory nexus that draws on research methods and critical theories to critique hegemony, oppression, asymmetrical power relations, and the normalization of these structures in society. The broader goal here is to foster social change in direct or indirect ways. Next, Mangual Figueroa discusses ethnographic approaches to the study of language education, emphasizing the local understandings and social significance of language use in diverse contexts, the view of language as constitutive of social context, and repertoires of semiotic resources used in interaction. She suggests that ethnographers of language education work with communities of minoritized populations to support social justice and to meet the present educational needs that these populations face. Allard's chapter, in turn, directs our attention to language and education research that incorporates an explicit focus on timescales into its theoretical frameworks and research methodologies. She considers studies researching how short-term interactions such as classroom discourse contribute to longer-term linguistic, academic, and identity development and how phenomena developed over long periods or events from distant historical moments influence short-term exchanges in the present moment.

Section 3 also offers chapters examining discourse analysis studies in language and education. Warriner and Anderson, in their chapter, review four major approaches to the study of language and discourse analysis in education, including anthropological, narrative, classroom-based, and multimodal discourse perspectives. They focus on the relationship between interaction and learning in both formal and informal educational contexts, as well as how underlying social systems shape and are shaped by interaction. Their chapter unpacks how identities are constructed in and through interaction and how embodiment, multimodality, and virtual spaces offer new units of analysis, raising important questions about how new modes of communication shape discursive methods of research and representation. De Mejía, in turn, centers her discussion on ethnographic approaches to the study of developing discourses and competences, teacher and student beliefs, as well as sociocultural and political factors in immersion and Content and Language Integrated Learning (CLIL) classrooms.

In addition, Sect. 3 includes chapters addressing multimodal and visual research methods for examining practices, discourses, and experiences of and around language. Rowsell and Collier consider research approaches to examining multimodal meaning making across diverse educational contexts with studies that incorporate

social semiotics, multimodal literacies, context, and transdisciplinary moves. They suggest that future research of multimodality needs to continue to explore the complexity of modes that merge in multimodal literacy events, contexts, and representations. Pitkänen-Huhta and Pietikäinen detail how visual methods have been used as a methodological tool in researching language teaching and learning. They examine the materiality of language and current methods and strategies (looking, seeing, and designing), such as discourse ethnographic approaches, that are used to study the contexts of language acquisition, multilingualism, and identity negotiations. Pitkänen-Huhta and Pietikäinen suggest that examining innovative ways of using languages, visualities, and technologies will yield new practices for language use, learning, and identity work. In the last chapter in this section, Cahnmann Taylor draws from ethnographic perspectives but hones in on the growing field of arts-based approaches to language and education research. She discusses how artistic forms of representation such as poetry, story, theater, and visual image have been used for data collection and analysis to explore the complexities and dynamics of language teaching and learning.

Section 4, "Language, Interaction and Education," considers micro-level linguistic and micro-level social analyses examining the interrelationships among language, interaction, and education. Garcez describes the research approach of micro-ethnography and its application to the study of socioculturally organized interactions and conversational routines in particular situational settings. Microethnography typically involves audiovisual recordings of naturally occurring social encounters in order to examine how interlocutors co-construct talk-in-interaction. Hellermann and Jakonen draw from a functional linguistic perspective of meaning making and microanalytic approaches to the study of how language, meaning, and learning is co-constructed in and through interaction. They suggest that future research continue to investigate theoretical perspectives through empirical studies and include discussion of how technologies change the nature of data collection and contexts for teaching and learning. Waring directs our attention to the influence and implications of conversation analysis (CA) on language education. Her review highlights how conversation analytic approaches enrich our understandings of the nature of interactional competence, the complexity of pedagogical practices in and outside the classroom, and the conceptualization of language acquisition and how that acquisition is accomplished over time. Waring suggests that descriptive work on teaching pedagogies and collaboration between conversation analysts and language teacher education scholars is imperative for the development of CA within language education. Next, Li reviews theoretical and research approaches to investigating both talk and body movements in face-to-face interaction, including approaches drawn from structural perspectives, conversation analysis, and interactional approaches. She highlights how these three approaches address the role of body movements in exhibiting emotions in educational interaction and multiactivity in education.

Lin discusses research approaches and methods ranging from cognitive processing and experimental perspectives on code-switching to the study of code-switching practices in classroom settings. She provides code-switching examples from studies in second, foreign, or heritage language acquisition. Lin also discusses

several challenges facing researchers such as the lack of fully developed, designed, and theorized studies and a shortage of interdisciplinary work. Martinez and Martínez consider how notions of race and racism are constructed and performed through language in varied educational contexts. They highlight research approaches that unpack the ideologies of language circulating in educational settings, with particular attention to the ideologies that result in practices that value mainstream languages as a prerequisite for learning in schools while devaluing nonmainstream languages as resistant to schooling.

Section 4 also includes chapters that examine how technology functions as a research tool for studying language and education (see also Thorne and May's volume in this edition of the *Encyclopedia*). Snyder and Tour examine cutting-edge research approaches to the study of literacy, learning, and technology. Their chapter reviews a range of different methods (e.g., ethnographic approaches, participatory action research) that have been employed to explain the meaning-making processes surrounding the use of digital technologies and how these may inform pedagogical practices. Snyder and Tour suggest that future research needs to draw on multiple perspectives to generate new understandings of the complex connections between literacy practices, learning, and technological innovations. Wan Mansor and Zakaria detail the development and current research methods in studying Computer Mediated Communication (CMC) in language and education. Their review highlights the contexts of emerging CMC sites, the role of CMC researchers, as well as the myriad interrelationships across technological innovation, research methods, and pedagogical practices. Wan Mansor and Zakaria call for research methods involving multidisciplinary and multiple perspectives that create active roles for the researcher and researched and focus on the use of emerging CMC research sites in language and education.

---

## Conclusion

Taken together, the 39 chapters of this volume in the third edition of the *Encyclopedia* provide a rich overview of the myriad research approaches within the field of language and education. Woven together here, these chapters highlight the foundational, current, and developing research theories, approaches, and methods employed to uncover the vast communicative resources and linguistic diversities within communities around the world, as well as individual and community experiences in a range of educational settings. As noted above, although the organization of these chapters reflects the "micro" and "macro" social/linguistic structure of the two previous editions of the *Encyclopedia*, many of the chapters in this third edition highlight ways of researching connections across these spaces. For instance, multiple chapters in this edition address how language ideologies and broader societal discourses are taken up in intimate, everyday interactions as well as how multilingual language teaching and learning practices in particular spaces are linked to national policies and global trends.

Reflecting both the current state of the field of language and education research, and the present state of our highly connected world, these chapters are both shaped by, and contribute to, current work in what is often referred to as superdiversity. Indeed, with millions of displaced individuals worldwide, there has perhaps never been a greater need for research-based, empirically informed language and education policies and practices. As editors of this volume, we hold the modest hope that the research guidance offered here will serve as one very small step to that end. The editors and authors have aimed to contribute meaningfully to current understandings and discussions about research methods employed to analyze language practices and experiences in diverse educational and societal contexts around the globe. The insights from this work, we hope, will inform the development of language and education policies and practices that are tailored to best serve the learning or teaching needs of individuals as well as work towards greater language justice and social equity.

We close by thanking the founding editor of the *Encyclopedia*, the late David Corson, and the editor of both the first edition of this particular volume and the 2nd edition of the *Encyclopedia*, Nancy Hornberger, for their early intellectual leadership on this project and foundational work. We also sincerely thank each of the chapter authors for their tireless efforts in writing, revising, and updating their chapters. Their work here is unpaid and entirely voluntary. We share with all of our authors the deep hope that these chapters provide useful support and practical guidance for the next generation of researchers of language and education. Your work is needed and important, and we wish you all the best.

Minneapolis

Kendall A. King  
Yi-Ju Lai

---

## References

- Archer, M. S. (1995). *Realist social theory: The morphogenetic approach*. Cambridge: Cambridge University Press.
- Beretta, A., Crookes, G., Gregg, K., & Long, M. (1994). Comment on van Lier 1994. *Applied Linguistics*, 15(3), 347.
- Blom, E., & Unsworth, S. (2010). *Experimental methods in language acquisition research*. Philadelphia/Amsterdam: John Benjamins.
- Canagarajah, A. S. (2013). *Literacy as translingual practice: Between communities and classrooms*. London: Routledge.
- Collins, J. (2012). Migration, sociolinguistic scale, and educational reproduction. *Anthropology & Education Quarterly*, 43(2), 192–213.
- Duff, P. A. (2015). Transnationalism, multilingualism, and identity. *Annual Review of Applied Linguistics*, 35, 57–80.
- Firth, A., & Wagner, J. (1997). On discourse, communication, and (some) fundamental concepts in SLA research. *Modern Language Journal*, 81(3), 285–300.

- Gass, S. (2015). Methodologies of second language acquisition. In M. Bigelow & J. Enns-Kananen (Eds.), *The Routledge handbook of educational linguistics* (pp. 9–22). New York/London: Routledge.
- Gregg, K. R. (2006). Taking a social turn for the worse: The language socialization paradigm for second language acquisition. *Second Language Research*, 22(4), 413–442.
- Hornberger, N. H. (1989). Continua of biliteracy. *Review of Educational Research*, 59(3), 271–296.
- Hornberger, N. H., & Corson, D. (Eds.) (1997). *Encyclopedia of language and education*. Springer Science & Business Media.
- Hulstijn, J. H., Young, R. F., Ortega, L., Bigelow, M., DeKeyser, R., Ellis, N. C., Lantolf, J. P., Mackey, A., & Talmy, S. (2014). Bridging the gap: Cognitive and social approaches to research in second language learning and teaching. *Studies in Second Language Acquisition*, 36(3), 361–421.
- King, K. A. (2008). Introduction. In K. King & N. H. Hornberger (Eds.), *Encyclopedia of language and education. Vol. 10: Research methods in language and education* (pp. xiii–xviii). New York: Springer.
- King, K. A., & Mackey, A. (2016). Research methodology in second language studies: Trends, concerns, and new directions. *Modern Language Journal*, 100, 209–227.
- King, K. A., & Bigelow, M. (in press). Multilingual education policy, superdiversity, and directions for educational equity. In M. Cook & J. Simpson (Eds.) *Routledge handbook of language and superdiversity*. New York: Routledge.
- Layder, D. (1997). *Modern social theory: Key debates and new directions*. London/Bristol: UCL Press.
- Lemke, J. L. (2000). Across the scales of time: Artifacts, activities, and meanings in ecosocial systems. *Mind, Culture, and Activity*, 7(4), 273–290.
- Lemke, J. L. (2002). Language development and identity: Multiple timescales in the social ecology of learning. In C. Kramsch (Ed.), *Language acquisition and language socialization* (pp. 68–87). New York: Continuum.
- Mackey, A., & Gass, S. M. (Eds.). (2012). *Research methods in second language acquisition: A practical guide*. Malden/Chichester/West Sussex: Wiley-Blackwell.
- Meissner, F., & Vertovec, S. (2015). Comparing super-diversity. *Ethnic and Racial Studies*, 38(4), 521–555.
- McKay, S., & Hornberger, N. H. (Eds.). (1996). *Sociolinguistics and language education*. Clevedon: Multilingual Matters.
- Nathan, M. (2011). *The economics of super-diversity: Findings from British cities, 2001–2006*. Spatial Economics Research Centre (SERC), London School of Economics and Political Sciences Discussion Papers, SERCDP0068.
- Ortner, S. B. (2006). *Anthropology and social theory: Culture, power, and the acting subject*. Durham/London: Duke University Press.
- Polio, C. (Ed.). (2014). Topics in research methods. *The Annual Review of Applied Linguistics*, 34, v–vi.

- Scollon, R., & Scollon, S. W. (2004). *Nexus analysis: Discourse and the emerging internet*. London: Routledge.
- Valentine, G. (2013). Living with difference: Proximity and encounter in urban life. *Geography*, 98, 4.
- van Lier, L. (1994). *The classroom and the language learner*. London: Longman.
- Vertovec, S. (2005, September 20). Opinion: Super-diversity revealed [Online]. *BBC News*. [http://news.bbc.co.uk/2/hi/uk\\_news/4266102.stm](http://news.bbc.co.uk/2/hi/uk_news/4266102.stm)
- Vertovec, S. (2007). Super-diversity and its implications. *Ethnic and Racial Studies*, 30(6), 1024–1054.
- Warriner, D. S. (2012). When the macro facilitates the micro: A study of regimentation and emergence in spoken interaction. *Anthropology & Education Quarterly*, 43(2), 173–191.
- Watson-Gegeo, K. A. (2004). Mind, language, and epistemology: Toward a language socialization paradigm for SLA. *Modern Language Journal*, 88(3), 331–350.
- Wortham, S. (2012). Beyond macro and micro in the linguistic anthropology of education. *Anthropology & Education Quarterly*, 43(2), 128–137.

---

## Acknowledgment

Thanks to the following for their key editorial support:

Consulting Editor: Nancy Hornberger

Editorial Assistant: Lincoln Dam



---

# Contents

<b>Part I Language, Society, and Education</b> .....	<b>1</b>
<b>Theoretical and Historical Perspectives on Researching the Sociology of Language and Education</b> .....	<b>3</b>
Joshua A. Fishman	
<b>Sociology of Language and Education: Empirical and Global Perspectives</b> .....	<b>15</b>
Valerie S. Jakar	
<b>Researching Globalization of English</b> .....	<b>27</b>
Joseph Sung-Yul Park	
<b>Investigating Language Education Policy</b> .....	<b>39</b>
Bernard Spolsky	
<b>Ethnography of Language Policy</b> .....	<b>53</b>
Teresa L. McCarty and Lu Liu	
<b>Researching Historical Perspectives on Language, Education, and Ideology</b> .....	<b>67</b>
Thomas Ricento	
<b>Censuses and Large-Scale Surveys in Language Research</b> .....	<b>83</b>
Jennifer Leeman	
<b>Researching Language Loss and Revitalization</b> .....	<b>99</b>
Leena Huss	
<b>Researching Media, Multilingualism, and Education</b> .....	<b>113</b>
Ingrid de Saint-Georges	
<b>Researching the Continua of Biliteracy</b> .....	<b>125</b>
Nancy H. Hornberger	

<b>Part II Language Variation, Acquisition, and Education</b> . . . . .	<b>143</b>
<b>Variationist Approaches to Language and Education</b> . . . . .	145
Kirk Hazen	
<b>Social Class in Language in Education Research</b> . . . . .	159
David Block	
<b>Researching Identity in Language and Education</b> . . . . .	171
Saeed Rezaei	
<b>Second Language Acquisition Research Methods</b> . . . . .	183
Rebekha Abbuhl and Alison Mackey	
<b>Methods in Multilingualism Research</b> . . . . .	195
Beatriz Lado and Cristina Sanz	
<b>Research Perspectives on Bilingualism and Bilingual Education</b> . . . . .	215
Li Wei	
<b>From Researching Translanguaging to Translanguaging Research</b> . . . . .	227
Li Wei and Ofelia García	
<b>Research Approaches to Narrative, Literacy, and Education</b> . . . . .	241
Gigliana Melzi and Margaret Caspe	
<b>Second Language Acquisition and Identity</b> . . . . .	255
Viniti Vaish	
<b>Part III Language, Culture, Discourse, and Education</b> . . . . .	<b>267</b>
<b>Ethnography and Language Education</b> . . . . .	269
Ariana Mangual Figueroa	
<b>Researching Language Socialization</b> . . . . .	283
Paul B. Garrett	
<b>Discourse Analysis in Educational Research</b> . . . . .	297
Doris Warriner and Kate T. Anderson	
<b>Researching Multimodality in Language and Education</b> . . . . .	311
Jennifer Rowsell and Diane R. Collier	
<b>Researching Developing Discourses and Competences in Immersion Classrooms</b> . . . . .	325
Anne-Marie de Mejía	
<b>Linguistic Ethnography</b> . . . . .	339
Angela Creese and Fiona Copland	

---

<b>Arts-Based Approaches to Inquiry in Language Education</b> .....	353
Melisa Cahnmann Taylor	
<b>Researching Timescales in Language and Education</b> .....	367
Elaine Allard	
<b>Critical Ethnography</b> .....	381
Deborah Palmer and Blanca Caldas	
<b>Visual Methods in Researching Language Practices and Language Learning: Looking at, Seeing, and Designing Language</b> .....	393
Anne Pitkänen-Huhta and Sari Pietikäinen	
<b>Narrative Inquiry and Multicultural Education</b> .....	407
Jubin Rahatzad, Hannah Dockrill, and JoAnn Phillion	
<b>Language Teacher Research Methods</b> .....	421
Manka M. Varghese and I-Chen Huang	
<b>Part IV Language, Interaction, and Education</b> .....	<b>433</b>
<b>Microethnography in the Classroom</b> .....	435
Pedro M. Garcez	
<b>Interactional Approaches to the Study of Classroom Discourse and Student Learning</b> .....	449
John Hellermann and Teppo Jakonen	
<b>Conversation Analytic Approaches to Language and Education</b> .....	463
Hansun Zhang Waring	
<b>Researching Body Movements and Interaction in Education</b> .....	475
Xiaoting Li	
<b>Code-Switching in the Classroom: Research Paradigms and Approaches</b> .....	487
Angel M. Y. Lin	
<b>Researching the Language of Race and Racism in Education</b> .....	503
Danny C. Martinez and Ramón A. Martínez	
<b>Research Approaches to the Study of Literacy, Learning, and Technology</b> .....	517
Ilana Snyder and Ekaterina Tour	
<b>Researching Computer-Mediated Communication</b> .....	531
Wan Fara WanMansor and Mohamad Hassan Zakaria	
<b>Index</b> .....	545

---

## About the Editors



**Kendall A. King** (Ph.D., University of Pennsylvania) is Professor of Second Language Education at the University of Minnesota, where she teaches and researches in the areas of sociolinguistics and language policy, with an emphasis on language minority students. Her recent publications appear in the *Modern Language Journal*, *Applied Linguistics*, and the *Journal of Language, Identity, and Education*. She served as the editor of the international journal, *Language Policy*, for 5 years and has long advocated for multilingual language policy in

her home state of Minnesota. King has written widely on Indigenous language revitalization, bilingual child development, and the language policies that shape immigrant and transnational student experiences in the USA, Ecuador, and Sweden. Her current research, based in Minneapolis, examines the educational policy and practices which (under)serve adolescent migrants with limited or interrupted formal schooling experiences.



**Yi-Ju Lai** is a doctoral student in Second Language Education at the University of Minnesota, where she teaches courses on applied linguistics, sociolinguistics, and language acquisition. Her research addresses the language socialization processes of multilingual international students into academic discourse practices and communities. Her work focuses on the multiple interactions where linguistic forms, communicative norms, institutional ideologies, epistemic stances, agency, and membership positioning are negotiated and constructed

between students and their interlocutors. Lai's work has appeared in *Anthropology News* and the *Journal of Sociolinguistics*. Her current research focus examines second language socialization of international teaching assistants and instructors

into US higher education norms, looking at the language-mediated activities and interactions between assistants/instructors and native speakers of English in university classrooms.



**Stephen May** is Professor of Education in Te Puna Wānanga (School of Māori and Indigenous Education) in the Faculty of Education and Social Work, University of Auckland, New Zealand. He is an international authority on language rights, language policy, bilingualism and bilingual education, and critical multicultural approaches to education and, to date, has published 15 books and over 90 articles and chapters in these areas. His key books include *The Multilingual Turn* (2014), *Language and Minority Rights* (2nd edition, 2012), and, with Christine Sleeter, *Critical Multiculturalism: Theory and Praxis* (2010). In addition to being

Editor-in-Chief of the 3rd edition of the *Encyclopedia of Language and Education*, he is a Founding Editor of the interdisciplinary journal, *Ethnicities*, and was from 2005 to 2015 Associate Editor of *Language Policy*. He is also a Fellow of the American Educational Research Association (AERA). His homepage is <http://www.education.auckland.ac.nz/uoa/stephen-may>.

---

## Advisory Board

- Suresh Canagarajah** Pennsylvania State University, University Park, PA, USA
- William Cope** Common Ground Publishing, Champaign, IL, USA
- Jim Cummins** University of Toronto, Toronto, ON, Canada
- Viv Edwards** University of Reading, Reading, UK
- Eli Hinkel** Seattle University, Seattle, WA, USA
- Francis Hult** Lund University, Lund, Sweden
- Nkonko Kamwangamalu** Howard University, Washington, DC, USA
- Gregory Kamwendo** University of Kwazulu-Natal, Durban, South Africa
- Claire Kramsch** University of California, Berkeley, CA, USA
- Rainer Enrique Hamel** Universidad Autónoma Metropolitana, Mexico City, Mexico
- Constant Leung** King's College, London, UK
- Li Wei** University College London, London, UK
- Luis Enrique Lopez** Universidad Mayor de San Simón, Cochabamba, Bolivia
- Marilyn Martin-Jones** University of Birmingham Edgbaston, Birmingham, UK
- Bonny Norton** University of British Columbia, Vancouver, BC, Canada
- Tope Ominiya** Roehampton University, London, UK
- Alastair Pennycook** University of Technology, Sydney, Australia
- Bernard Spolsky** Bar-Ilan University, Ramat Gan, Israel
- Lionel Wee** National University of Singapore, Singapore, Singapore
- Jane Zuengler** University of Wisconsin, Madison, WI, USA

---

## External Reviewers

---

### **Research Methods in Language and Education**

Francis M. Hult  
Carey Jewitt  
Nelson Flores  
Numa P. Markee  
Elaine Chun  
Christoph Hafner

---

## Contributors

**Rebekha Abbuhl** Department of Linguistics, California State University, Long Beach, CA, USA

**Elaine Allard** Educational Studies, Swarthmore College, Swarthmore, PA, USA

**Kate T. Anderson** Division of Educational Leadership and Innovation, Arizona State University, Tempe, AZ, USA

**David Block** ICREA/University of Lleida, Lleida, Spain

**Blanca Caldas** Second Language Education and Elementary Education, University of Minnesota, Twin Cities, Minneapolis, MN, USA

**Melisa Cahnmann Taylor** Language and Literacy Education, University of Georgia, Athens, GA, USA

**Margaret Caspe** Harvard Family Research Project, Harvard University, Cambridge, MA, USA

**Diane R. Collier** Department of Teacher Education, Brock University, Saint Catharines, ON, Canada

**Fiona Copland** Faculty of Social Sciences, University of Stirling, Stirling, United Kingdom

**Angela Creese** MOSAIC Center for Research on Multilingualism, University of Birmingham, Birmingham, UK

**Anne-Marie de Mejía** Facultad de Educación, Universidad de los Andes, Bogotá, Colombia

**Ingrid de Saint-Georges** Educational Science, University of Luxembourg, Belval, Luxembourg

**Hannah Dockrill** College of Education, Purdue University, West Lafayette, IN, USA



**Joshua A. Fishman** Distinguished University Research Professor of Social Sciences, Yeshiva University, Albert Einstein College of Medicine Campus, Bronx, New York, NY, USA

**Pedro M. Garcez** Instituto de Letras/Linguistics, Federal University of Rio Grande do Sul (UFRGS) and Brazilian National Council for Scientific and Technological Development (CNPq), Porto Alegre, RS, Brazil

**Ofelia García** Urban Education, Hispanic and Luso-Brazilian Literatures and Languages, City University of New York, New York, NY, USA

**Paul B. Garrett** Department of Anthropology, Temple University, Philadelphia, PA, USA

**Kirk Hazen** Department of English, Eberly College of Arts and Sciences, West Virginia University, Morgantown, WV, USA

**John Hellermann** Department of Applied Linguistics, Portland State University, Portland, OR, USA

**Nancy H. Hornberger** Graduate School of Education, University of Pennsylvania, Philadelphia, PA, USA

**I-Chen Huang** Department of English, Wenzao Ursuline University of Languages, Kaohsiung, Taiwan

**Leena Huss** The Hugo Valentin Centre, Uppsala University, Uppsala, Sweden

**Valerie S. Jakar** Shaanan Academic College of Education, Haifa, Israel

**Teppo Jakonen** Centre for Applied Language Studies, University of Jyväskylä, Jyväskylä, Finland

**Beatriz Lado** Department of Languages and Literatures, Lehman College and The Graduate Center (CUNY), New York City, NY, USA

**Jennifer Leeman** Department of Modern and Classical Languages, George Mason University, Fairfax, VA, USA

**Xiaoting Li** East Asian Studies, University of Alberta, Edmonton, AB, Canada

**Angel M. Y. Lin** Faculty of Education, The University of Hong Kong, Hong Kong, China

**Lu Liu** Graduate School of Education and Information Studies, University of California Los Angeles, Los Angeles, CA, USA

**Alison Mackey** Department of Linguistics, Georgetown University, Washington, DC, USA

**Ariana Mangual Figueroa** Graduate School of Education, Rutgers University, New Brunswick, NJ, USA

**Danny C. Martinez** School of Education, University of California at Davis, California, CA, USA

**Ramón A. Martínez** Graduate School of Education, Center for Comparative Studies in Race and Ethnicity, Stanford University, Stanford, CA, USA

**Teresa L. McCarty** Graduate School of Education and Information Studies, University of California Los Angeles, Los Angeles, CA, USA

**Gigliana Melzi** Applied Psychology, Steinhardt School of Culture, Education and Human Development, New York University, New York, NY, USA

**Deborah Palmer** School of Education, University of Colorado, Boulder, CO, USA

**Joseph Sung-Yul Park** Department of English Language and Literature, National University of Singapore, Singapore, Singapore

**Sari Pietikäinen** Department of Languages and Discourse Studies, University of Jyväskylä, Jyväskylä, Finland

**Anne Pitkänen-Huhta** Department of Languages, University of Jyväskylä, Jyväskylä, Finland

**JoAnn Phillion** College of Education, Purdue University, West Lafayette, IN, USA

**Jubin Rahatzad** College of Education, Purdue University, West Lafayette, IN, USA

**Saeed Rezaei** Languages and Linguistics Center, Sharif University of Technology, Tehran, Iran

**Thomas Ricento** Werklund School of Education, University of Calgary, Calgary, AB, Canada

**Jennifer Rowsell** Department of Teacher Education, Canada Research Chair in Multiliteracies Brock University, Ontario, ON, Canada

**Cristina Sanz** Department of Spanish and Portuguese, Georgetown University, Bunn Intercultural Center, Washington, DC, USA

**Iiana Snyder** Faculty of Education, Monash University, Clayton, VIC, Australia

**Bernard Spolsky** Bar-Ilan University, Ramat Gan, Israel

**Ekaterina Tour** Monash University, Melbourne, VIC, Australia

**Viniti Vaish** English Language and Literature Academic Group, National Institute of Education, Nanyang Technological University (NIE/NTU), Singapore, Singapore

---

**Manka M. Varghese** College of Education, University of Washington, Seattle, WA, USA

**Wan Fara WanMansor** Foreign Language Department, Faculty of Arts, Taif University, Taif, Saudi Arabia

**Hansun Zhang Waring** Applied Linguistics and TESOL, Teachers College, Columbia University, New York, NY, USA

**Doris Warriner** Department of English, College of Liberal Arts and Sciences, Arizona State University, Tempe, AZ, USA

**Li Wei** UCL Institute of Education, University College London, London, UK

**Mohamad Hassan Zakaria** Foreign Language Department, Faculty of Arts, Taif University, Taif, Saudi Arabia

---

**Part I**

**Language, Society, and Education**

---

# Theoretical and Historical Perspectives on Researching the Sociology of Language and Education

Joshua A. Fishman

---

## Abstract

This contribution traces the development of the sociology of language and its key research approaches. Close attention is paid to the contrast between research approaches that focus on *verstehende* (understanding) and those whose primary goal is *erklärende* (explanatory). The piece concludes that the sociology of language and education must be inclusive enough and supportive enough to provide room and recognition for both *erklärende* and *verstehende* approaches to its subject matter.

---

## Keywords

Sociolinguistics • Ethnography • Questionnaires • ANOVA

## Contents

Introduction: The Sociology of Language .....	4
Early Developments in the Sociology of Language .....	4
Major Contributions .....	5
Contributions from Sociology .....	5
Connections to Education .....	6
Key Research Approaches .....	7
Problems and Difficulties: Reality and Complexity .....	9
<i>Verstehende</i> Versus <i>Erklärende</i> Sciences and Their Corresponding Methods .....	10
<i>Verstehende</i> Research to the Rescue .....	12

---

Sadly, Dr. Joshua Fishman is no longer living; we republish his chapter here, unchanged from the previous edition.

J.A. Fishman (✉)

Distinguished University Research Professor of Social Sciences, Yeshiva University, Albert Einstein College of Medicine Campus, Bronx, New York, NY, USA

---

Future Directions .....	13
Cross-References .....	13
References .....	13

---

## Introduction: The Sociology of Language

The designation “sociology of language” is often used in conscious distinction to the designation “sociolinguistics.” The intent of this distinction is commonly relevant both to personal disciplinary orientation and to the level of data aggregation preferred by the researcher. From a disciplinary point of view, the designation “sociology of language,” rather than “sociolinguistics,” implies a greater concern with sociology than with linguistics, on the one hand, and a greater preference for higher levels of behavioral data collection (“higher” in the sense of more abstract, i.e., further removed from directly observed phenomena) and for higher levels of data aggregation on the other hand.

This contribution will trace the development of sociology of language and its key research approaches. It will consider the challenges of different research approaches and the relevance of those that focus on *verstehende* (understanding) and those whose primary goal is *erklärende* (explanatory).

---

## Early Developments in the Sociology of Language

The sociology of language has developed alongside of sociolinguistics at least since the summer of 1964, when the modern study of language in social contexts was (re) constituted by a specially convened group of primarily US scholars. The linguists (mostly, anthropological linguists) and sociologists (most of them macrolevel oriented) spent an 8-week faculty seminar at the Summer Linguistic Institute, held that summer at Indiana University in Bloomington (Tucker and Paulston 1997). Since linguists were already focused upon language behavior (whereas sociologists were not, by and large), the perspective of “sociolinguistics” had greater momentum from the outset and could look forward to an academic home in departments of linguistics from the very first days onward. While a few of the Bloomington seminar sociologists immediately began to define themselves as “sociologists of language” (indeed, some not present at the Bloomington seminar had already so defined themselves much earlier, viz., Herzler 1965; Cohen 1956), they did not form a cohesive interest group, either then or afterward, few sociology departments being interested in the new specialty area. Even the designation “sociologists” was somewhat questionable for some of them, since it included the political scientists and the social psychologists among them. Accordingly, although the sociology of language began (and has largely remained) as a recognizable perspective of individual scholars, it never became a well-defined theoretical school nor developed a distinctive research methodology. It has remained a minority position within the total sociolinguistic enterprise, particularly in the USA.

Like sociology itself, the sociology of language has neither well-defined limits nor methods distinctly its own (see Fishman 1965, 1968, 1970, 1972). As a result, whereas sociolinguistics has gravitated toward microanalyses of snippets of “talk” and preselected conversations (Gumperz 1982) or toward particular genres of preselected texts (Hymes 1981) and therefore has no problem incorporating samples of actual speech or recitation in its presentations, the sociology of language has largely been “social problem” oriented (e.g., bilingual education, language maintenance and language shift, reversing language shift, the spread of English, language death, etc.), often utilizing contrasted polities, population groupings, and even the world at large as its universe of study and generalization for inquires into one macro-topic or another. As a result, the data of actual speech is no longer evident in its reports, such data being replaced by language or variety names or categories.

---

## Major Contributions

### Contributions from Sociology

“The sociology” of any topic involves the social structure or differentiation of its manifestations in society. A sociological analysis frequently compares individuals in different ethnic groups, racial groups, religious groups, professional groups, age groups, occupational groups, or economic groups with respect to a particular social behavior (attendance at a Yankee game, participation in a general strike, armed forces service, participation in the elections, engaging in recreational reading, etc.). Some subgroups (ethnic group 1, ethnic group 2, ethnic group  $n$ ) may well manifest more of this behavior than others. In that case, the investigator may conclude that ethnicity does play a role in the social behavior being studied (participation in the May Day parade in New York City) or may try to push the analysis further to try to relate the ethnic differences that have been discovered to differences in family income, individual education, immigration status, etc. What may initially have seemed to be ethnic differences per se may, upon further inquiry, be more fully explainable in terms of economic or education differences between the groups involved. Sociologists will derive their hypotheses from the manifold previous studies that have been already been completed on the categorical groups that they are studying in a particular inquiry and on the social dimensions of concern to them (education, income, age, citizenship, etc.). Of course there will be a language variable involved too in the sociology of language and education (e.g., speaking a LOTE [language other than English] at home), but we will turn to such distinctly language variables below.

Sociological interpretations as to “causal factors” typically stop at the societal or group-membership level. This leaves it to other investigators (sometimes from other disciplines, including sociolinguistics) to investigate the role of more individual or psychological factors prompting attendance at Yankee games or participation in May Day marches. Whether or not to extend one’s research to the individual level too will also depend on the investigator’s (inter)disciplinary training and particular focus of

inquiry. Although personality factors may be involved in Yankee game attendance, neither the sociology of language nor the Yankees per se may be interested in sponsoring research on such variables because they would provide little valuable information to them that could easily be incorporated into their own prior *modus operandi*.

## **Connections to Education**

The sociology of language has been drawn to the study of language in education more by need than by prior intellectual interest. Each of the abovementioned macro-topics has most often been researched within educational settings and institutions (school systems, school districts, school grades, school rooms, etc.). School settings and situations are often selected for sociology of language inquiry because of various assets that they possess and prominently manifest. Schools have research budgets to expend, populations (including minority populations with language problems) that can easily be tapped as data-collection participants, and qualified staffs that can be relied upon to keep order, provide background data, and, in general, assist with the “bookkeeping” that all research entails, shielding investigators from interruptions, interference, or other disturbances. Few of the aforementioned assets amount to theoretical or substantive preferences, and, as a result, the outcomes of such investigations are often both less specifically relevant for education and more relevant for larger-scale societal institutions and social processes more generally than might otherwise have been anticipated.

Although “education” is commonly defined as school-situated or school-related input or output, that need not necessarily always be the case. Education need not be conceptualized in a manner that limits it to either formal settings, curricular emphases, or stereotypic roles (“students,” “teachers,” “administrators,” “school board members,” “parent body,” etc.). Language use during recess in the school yard (playground) is a perfectly reasonable example of simultaneously minimizing formal school influences on informal language use while still easily locating subjects of both sexes and various ages. More generally, therefore, education need not be limited to formal settings or scheduled curricular processes. “Education” may be taken in its broadest generic sense of “to lead, rear, bring up,” whether by example, instruction, or other influences, planned or unplanned, and with or without extrafamilial intervention.

In its most general terms then, education can be seen as a lifelong process of elicited responses, growth, development, and change. The sociology of language and education, therefore, necessarily focuses on only part of the total educational process that pertains to language in society but that is an important part indeed, language being both a major part of the input and a major part of the output of the entire process of education in society, regardless of its localizations. All in all, the sociology of language and education entails a triangulation between societal influences, educational processes, and language input or output. The need to include data collection and theoretically guided interpretation on three different dimensions contributes both to the difficulty and to the stimulation encountered in research on the sociology of language and education.



## Key Research Approaches

The social sciences in general, and the sociology of language and education (SLE) among them, share a small array of research methods and techniques. This array extends from ethnography and observation, at one extreme, through to controlled experiments, at the other, with correlational studies based upon content analyses, questionnaires, and other investigator-constructed “tests” occupying a middle ground between the two extremes. Each of these methods possesses its very own and distinctive advantages and disadvantages.

*Ethnography*, the classical approach of anthropology, based upon the in situ fieldwork observations and recordings of trained and sensitized observers, has gained a considerable following during the past half century in conjunction with the study of language and education.

It typically pursues the formulation, disconfirmation, or confirmation of hypotheses (e.g., “Teachers in X-town public schools reinforce English only speaking students more often and more positively than they do speakers of LOTEs”) by means of a large number of extensive observations in various school settings. Ethnographic reports typically include many verbatim excerpts from teacher-pupil interaction, as well as holistic descriptions of persons, places, and events that provide the reader (or viewer of filmed information) with a feel for the “real thing,” second only to being “there” while ongoing life unfolds. This “slice-of-life” realism is obtained at a price, as is the case with every research method bar none.

Ethnography finds it difficult to control certain factors (e.g., pupil social class, ethnicity, age, general attractiveness, etc.) while focusing on others, primarily because life does not present itself naturalistically in terms of neatly controlled but otherwise comparable packages. Of course, given sufficient experimenter time and funds, all of these secondary “causes” or elicitors of teacher reinforcement can be observed in action, and the differences between their rates can be noted and taken into consideration as indications of stronger or weaker co-causes than the major one (pupil’s variable classroom usage) and their separate or combined effect upon or modification thereof. However, researchers seldom if ever have sufficient time and resources, and ethnography is, therefore, not an easy or precise method of unraveling complex interactions between the large number of possibly contributory ongoing aspects of any real-live interaction. An additional concern is that of observer reliability and validity. Wherever there is only a single personally invested observer for any data set, we are left with the problems of observer bias, observer consistency over time, and the entire “issue of degree” of any observed and counted “teacher reinforcement” versus those not counted because they are simply unnoticed or judged to be too weak or ephemeral to count. Investigators also obviously differ from one another in their “ethnographic sensitivity” or “ethnographic aptitude,” and, therefore, although the method provides much direct and immediate researcher gratification, it is so labor intensive and so bound up with the quirks of a single observer that some researchers have concluded that other methods are needed (or needed in addition) for the sociology of language and education if its frequent confounding of method and researcher is soon to be overcome.

*Controlled experiments*, at the other end of the methodological continuum, are the characteristically preferred method of psychological research. Whereas ethnography sacrifices precision and complexity so that it can maximize “holistic realism,” exactly the opposite is true for controlled experiments. Thus, in a study of teacher interpretations of English-Spanish code-switching by pupils, three different pre-filmed scenarios (representing high, medium, and low degrees of code-switching by the same group of student actor-confederates) were viewed by randomly assigned Black, White, and Latino teachers in a large metropolitan high school, each of whom viewed only one scenario. After their viewing the scenario to which they had been assigned, teachers were debriefed as to their knowledge of Spanish, frequency, and types of out-of-school interactions with Latinos, attitudes toward switching, and their interpretations of the overt and the latent meanings of 20 switches that had been built into each scenario. Variables that were excluded from research attention (e.g., teacher age, experience, and attitudes toward race/ethnicity) were “controlled out” of the study by means of random selection and random assignment of teachers to switching groups, so that these variables could not affect any discovered “between teacher and group” differences with respect to levels of switching at more than a “chance” level. Unlike ethnographic researchers, experimental researchers never have the satisfaction of experiencing the reality of “actually having been there.” On the other hand, the latter have the satisfaction of precise answers to precise questions (e.g., does intensity of switching behavior among students effect teacher understanding of latent meaning among teachers who are White and non-Latino?), with the probability of error (false negatives and false positives) being known in connection with answering each such question.

Somewhere near the middle of the continuum of naturalness and precision are the *questionnaire methods* (including most investigator-constructed data elicitation methods, even if they are not of the traditional questionnaire type, e.g., *guided interviews*, *observational checkoffs*, certain *projective techniques*, etc.). Wherever total scores can be derived independently for each member of a studied sample from a summation of that member’s item scores (Fishman and Galguerra 2003), both fully structured and less-structured elicitation methods can be constructed by means of exacting item-analysis methods and can be tried out and improved, item by item, for both item and total instrument reliability and validity.

The only conditions or limitations on the latter claim are (i) that all item scores be independent of each other (i.e., “non-iterative”) and (ii) that a single criterion measurable in “more vs. less” terms be applicable to them all. Thus, for a criterion such as amount of switching during a prior unstructured conversation on “What I do after school,” the predictors of switching can be true-false (or other dichotomized) items, attitudinal or behavioral degree items (fully agree, agree more than disagree, neutral, disagree more than agree, totally disagree), investigator observed checkoff items, projective or other interpretation items with a choice among several enumerated replies, etc. Thus, although formal and semiformal measurements provide neither for the naturalness and holism of ethnographic methods nor for the exact estimation of “error variance” in responses (i.e., variation on factors that the investigator prefers to exclude from a given study) of experimental methods, they do

possess several significant benefits of their own, particularly with respect to demonstrable reliability and validity or the lack thereof.

The major lesson from the brief methodological review in this section is that there is no fool-proof research method for the sociology of language and education. Nor are its researchers methodological factotums, each being most comfortable and productive at a certain point along the entire methodological range. There is no methodological orthodoxy that pervades the entire field, to which all funding agencies, research centers, and journals pay allegiance. A greater or smaller degree of methodological heterodoxy is both the rule and is very much to be recommended as well. Only by increasing the methodological range of one's own competence and comfort can investigators really weigh all of the assets and debits of any choice among them in each particular study that is undertaken. Methods and researchers should never become fully redundant considerations. The trustworthiness of research findings are much enhanced by multi-method and multi-investigator replications, both within and between topical and subtopical areas of the sociology of language and education.

---

## **Problems and Difficulties: Reality and Complexity**

Every bit of research that is reported was conceived of as a means of tapping into both the reality and the richness of "actual life." However, reality is complexly multilayered, and it is very difficult (or perhaps even impossible) to be sure that one has captured enough of the subtle layering of any dimension being studied to be able to draw inferences pertaining to these dimension as a whole. Teacher acceptance of code-switching and code-switching per se both present many obvious and subtle examples of this difficulty.

In our discussion of factors contributing to teacher acceptance of switching, we have recognized at least some of the complexity of common influences on both teachers and bilingual pupil behavior. We have not doubted that there may be other factors at play here, but we have decided to either treat them as "error variance" or to "control them out" via random selection of subjects and random assignment of subjects to differing intensities of switching presentations. Both questionnaire data and experimental data can be subjected to a statistical analysis via a technique known as *analysis of variance (ANOVA)*. This technique essentially compares the variation associated with the data related to any particular dimension of analysis with the total variation exhibited by the data as a whole. Only if the latter is sufficiently great relative to the former can that particular dimension be considered a significant one (i.e., one unlikely to be merely a chance finding due to random sampling factors alone).

While it is impossible in a single brief article to render this technique intuitively transparent, it becomes even more useful if an outside criterion is also available (e.g., the ratings of expert judges [speech therapists] of the switching frequency of each student during several months of interactive observation with a variety of "others" and in a variety of "settings"); then this criterion can be used to gauge the extent to

which any predictive dimension by itself (e.g., race of student or bilinguality of the teacher), or all of them taken together, account(s) for the variance on the criterion. In this manner, the investigator can tell whether the criterion is adequately and significantly accounted for by the research instruments utilized. Obviously, the higher the correlation between the two, the more reliable and valid the explanatory capacity of the particular dimension or set of dimensions. But this crucial determination, available only for experimental and questionnaire data, does not convince ethnographers that these “other” methodologies have studied “the real thing” to any degree similar to that attained by their own studies. Similarly, the quantitative analysts are never convinced by the qualitative findings produced via ethnographic research. Why not?

Ethnography’s implications that its method (and its alone?) can study “the real thing” (and, therefore, “discover the real truth” about it) raise an intricate set of fundamental issues for the sociology of language and education and for social research more generally. How do we know “real” reality and recognize it when we have (or have not) found it? Is finding actual reality (and all of it) the sine qua non of research methodology and of the researcher’s craft? This query touches upon an old and painful dispute that extends far beyond the boundary of the sociology of language and education.

### ***Verstehende Versus Erklärende Sciences and Their Corresponding Methods***

The time has come, as it ultimately does in all social science that maintains a links with the most distinguished thinkers of its own past glories, for a few German words. More than 150 years ago, beginning even before the Bismarckian unification of Germany in the mid-nineteenth century and accelerating significantly thereafter, both the physical and the social sciences were essentially German preserves. It was not until the rise of Nazism, approximately 75 years ago, that this leadership clearly passed to the Anglo-American orbit where it largely remains until this day. Accordingly, it is not merely a silly nuisance that the “human,” “mental,” or “cultural” sciences retain a few particularly apt German terms to this very day. *Gestalt*, *zeitgeist*, *wissenschaft*, *volksprache*, *gemeinschaft/gesellschaft*, and *ausbau/abstand* are among those that it would be a pity to give up, because for several generations, many of our theories and findings have been formulated with them and through them, even if (as happens in all scientific fields) most of these have become substantially modified or even eliminated during this same period. These terms remind us of where we have been intellectually, and unless we know where we have been, we cannot really appreciate how we have gotten where we are (or think we are) today and where we would like to be tomorrow. Among these are the two terms that I will introduce here, *verstehende* and *erklärende*, that represent two kinds of conceptual goals and methodological procedures for scientific research.

*SLE as an Erklärende Science.* One school of German social science thought firmly believed that the rigorous methods and refined quantification of the exact sciences were not only proper and desirable but crucial models and methods for the

social sciences to aspire and work toward. The goal of such sciences was *erklahrung*: explanation. Today, when we think of the “explanation” of any variable in human behavior, it is exactly its variation or variability that challenges us. Why does it wax and wane in the same human subjects on different occasions and why do two different human groups differ with respect to the human behavior being examined such that Group A stands higher than Group B on some occasions while the opposite is true on others? Since this is not the case with respect to the measurement of properties of inanimate objects, the discovery of constant and inescapable variation in human behavior was originally a matter of great anxiety (not to say consternation) among scholars in the latter area.

In the beginning, the variation noted was attributed to errors of measurement, laxity in the training of measurers, or lack of consensus as to the proper units of measurement for research on human behavior. The psychophysicist Gustav T. Fechner (1801–1877) was so distraught by this phenomenon of inescapable human variation, individually or in groups, and by his obvious failures in trying to overcome or remedy it via utilizing different units of measurement, different methods of measurement, or different methods of training measurers that he ultimately went mad due to the aggravation and humiliation that he anticipated in that connection and that he understood to be a result of his own scientific shortcomings. It was almost a century later before the social and behavioral sciences fully understood that it was precisely the study and explanation of this variation that constituted their major responsibility and analytic task. From then onward, a large proportion of social scientists began to differentiate between true variance and error variance and between expected (and, therefore, insignificant) variance and unusual (and therefore significant) variance. The “standard error of measurement” of any measure being employed enabled investigators to distinguish between normal variation and clearly unusual variation and to focus their explanatory efforts on the latter. Such clearly unusual variation from the expected might be attributable to “independent variables” that the experimenter per se either manipulated or that the researcher discovered to exist to different degrees “in the field,” so that their impact on the “dependent variable” could be studied both separately and together.

Briefly put, “explanatory (*erklarende*)” research is so named because it attempts to *explain* the degree of variation in the dependent variable in terms of degrees of variation (whether experimenter manipulated or field encountered) in the independent variable(s) under study. Such research can also inform its practitioners and advocates of the extent to which the total variance in the dependent variable still remains unexplained (unaccounted for) by the independent variable(s) under study and by the measuring devices employed. This is important because it enables investigators to realize whether explanatory progress is being made, over time and study after study, when focusing upon the same independent variable. Even if this *is* the case, then in the future the recording, observing and stimulus conveying instruments can still be improved and honed. If it is *not* the case, then it might be appropriate to start all over again, not only with instrumentation but with the formulation of underlying hypotheses, predictive (“independent”) variables, and the “unitization” (units of measurement) established for both.

Rigorous though the above-sketched approach may seem, it still has its skeptics and nonbelievers, primarily because it has been overpromised and has, inevitably, underachieved in explanatory power. Therefore, we now turn, in closing, to the *verstehende* approach to research in the sociology of language and education.

### **Verstehende Research to the Rescue**

Even its most adamant defenders must grant that the *erklärende* model in social research has not turned out to be as fruitful as originally expected while, at the same time, natural or physical science research utilizing this very approach has gone on from one success to another, in one substantive area after another. As a result, the social sciences have remained, in the eyes of many of its most prominent investigators, singularly unreformed and unenriched by the adoption of the rigorous *erklärende* research model. Accordingly, many researchers (particularly including many of the young and female among them) have returned to the previously much maligned *verstehende* model (carefully avoiding or sidestepping the Fechnerian error in connection with behavioral variance). The renewed *verstehende* model is anything but “apologetic” concerning any possible errors of the past (certainly not for that part of the past for which its practitioners assume no responsibility whatsoever).

Why, its critics ask, has the *erklärende* model failed to produce satisfying results? Because the complexity of human behavior is so great and so manifold that *erklärung* in neutral and precise measurement terms is essentially impossible with respect to it. Instead of the false god of *erklärung* (explanation), it is claimed that the human sciences should pursue the more limited but also perhaps the more appropriate model of *verstehen* (understanding). *Verstehen* does not assume a physical/natural sciences model. Quite the contrary, it proceeds on the basis of seeking a disciplined and careful human understanding, that is, the understanding of human behavior that only another human being can achieve, derived from observation and empathy. *Verstehen* does not pursue the explanation of variance but, rather, the grasping of holistic and “undessicated” behavioral phenomena, at the very level as do most adults who are native co-members of the same culture. Cultural understanding is and should be the proper goal of *verstehende* science, being the only goal that is distinctly appropriate for research on human subjects. Adult-child interaction that socializes infants into panhuman but also into distinctly Xian culture and teacher-pupil interaction also guides neophytes into panhuman but also into distinctly Xian school-learning culture. It also renders possible the recording and the analysis of the exact language use and behavior of any such interactions, something that *erklärende* research has well-nigh abandoned at the verbatim level.

This is a level of research involvement (problem definition, data collection and processing, and conclusion derivation) which is so different from that of *erklärende* research that the two often have very little to share with each other. When basic methods are very far apart from each other, then research traditions unfortunately become soliloquies rather than confederates in a common venture. Regrettable

though that may be for the pursuit of knowledge within the total enterprise of the SLE, most find it to be preferable to the constant skirmishing and mutually recriminating rejection that would and once did result from forcing incommensurables to interact and collaborate.

---

## Future Directions

The total research enterprise of SLE must be inclusive enough and supportive enough to provide room and recognition for both *erklärende* and *verstehende* approaches to its subject matter. The rift between these different approaches is sufficiently recent that few researchers have thus far even had the opportunity to attempt to be trained so as to be equally at home and equally proficient in both approaches, so as to be able to choose between them (or to combine them) on substantive grounds rather than on personal, emotional ones. Perhaps that outcome will be a by-product of the twenty-first century that stretches immediately ahead. *Ojalá!*

---

## Cross-References

- ▶ [Censuses and Large-Scale Surveys in Language Research](#)
- ▶ [Ethnography and Language Education](#)
- ▶ [Ethnography of Language Policy](#)
- ▶ [Sociology of Language and Education: Empirical and Global Perspectives](#)

---

## References

- Cohen, M. (1956). *Pour une sociologie du langage*. Paris: Albin Michel.
- Fishman, J. A. (1965). Who speaks what language to whom and when? *La Linguistique*, 2, 67–88.
- Fishman, J. A. (Ed.). (1968). *Readings in the sociology of language*. The Hague: Mouton.
- Fishman, J. A. (1970). *Sociolinguistics: A brief introduction*. Rowley: Newbury House.
- Fishman, J. A. (1972). *Language in sociocultural change. Essays by Joshua A. Fishman*. Stanford: Stanford University Press.
- Fishman, J. A., & Galguera, T. (2003). Introduction to test construction in the social and behavioral sciences: A practical guide. Rowman & Littlefield Publishers.
- Gumperz, J. (1982). *Discourse strategies*. Cambridge: Cambridge University Press.
- Herzler, J. O. (1965). *The sociology of language*. New York: Random House.
- Hymes, D. (1981). *'In vain I tried to tell you': Essays in Native American Ethnopoetics*. Philadelphia: University of Pennsylvania Press.
- Tucker, R., & Paulson, C. (Eds.). (1997). *The early days of sociolinguistics*. Dallas: Summer Institute of Linguistics Press.

---

# Sociology of Language and Education: Empirical and Global Perspectives

Valerie S. Jakar

---

## Abstract

This chapter first gives an overview of early developments and research orientations in the study of sociology of language and education and then offers an account of some recent studies which reflect sociolinguistic changes and developments, both macro and micro. It concludes with discussion on the appropriate types of research methodology that are adequate for studies of the complexities of today's society with regard to globalization and linguistic hegemony. Focal areas that are addressed are language policy, language status, language maintenance (of indigenous varieties), and language education, be they in rural communities or in multinational sites.

---

## Keywords

Sociolinguistics • Mixed methods • Globalization • Transnational mobility

## Contents

Introduction .....	16
Early Developments .....	16
Major Current Contributions .....	19
Challenges and Problems .....	21
Future Directions .....	22
Cross-References .....	23
Related Articles in the Encyclopedia of Language and Education .....	23
References .....	23

---

V.S. Jakar (✉)  
Shaanan Academic College of Education, Haifa, Israel  
e-mail: [vsjakar@gmail.com](mailto:vsjakar@gmail.com)



---

## Introduction

Major areas of inquiry in the sociology of language generally are language contact (language spread, shift, loss, and revitalization), language conflict and language attitudes, and language planning and policy Cooper (1989); Fishman (1991, 2001). Sociology of language and education (SLE), which seeks to describe and explain the relationships between society and language in and of education, addresses the above issues in relation to schooling and other educational entities. We note increasing concern, in recent decades, with understanding the role language plays in postcolonial societies, at both the micro and the macro level, as “the vehicle for identifying, manipulating, and changing power relations between people particularly in educational institutions” which are viewed as sites where discourse practices can “repress, dominate, and disempower diverse groups whose practices differ from the norms that it establishes” (Corson 2001, p. 16).

Notable trends in SLE research can be traced to the 1960s and 1970s, to scholars such as Fishman, Ferguson, Bernstein, and Labov, but current research, impacted by worldwide developments, embraces broader issues, associated with global affairs and issues of identity. The waves of international migration in many parts of the world, together with the acceleration of the use of communication technologies and the resultant global networking, have posed new linguistic challenges for researchers and educators alike.

SLE research utilizes a diverse and complex array of methodologies set in both the positivist and constructivist traditions (Henze and Davis 1999) employing quantitative and qualitative approaches to investigate sociolinguistic phenomena in educational settings. While some researchers continue to borrow and adapt methodologies from the fields of sociology, anthropology, social psychology, and linguistics (see, e.g., Darquennes 2015, on “linguistic profiling” and “discourse analysis”), others are generating unique forms based in the amalgamation of several distinct approaches, arriving at what is now known as “mixed-method” research (see Rampton et al. 2002).

This chapter first reviews early developments and research orientations in SLE and then offers an account of some major contributions of recent years. It concludes with discussion on the appropriate types of research methodology for studies of complex language and education situations.

---

## Early Developments

The pioneering work of Joshua Fishman (1971) in the sociology of language triggered great interest in investigating the social organization of language behavior as well as the applications of findings to areas such as language teaching and educational policy decisions. Early research sought to describe speech (and writing) communities (Gumperz 1968) and to answer the question “who speaks (or writes) what language . . . to whom and when and to what end?” (Fishman 1971, p. 46). In comparing language usage norms, researchers conducted detailed case studies, based

on descriptive accounts coupled with data from censuses and surveys, of language use and language attitudes. In this early work, scholars identified phenomena and concepts that have become part of the established vocabulary of SLE research. For example, Ferguson (1959) used the (Greek-derived) term *diglossia* (meaning two languages) for situations where two varieties of the same language were used in the same community but for different functions and with different status accorded to each. Fishman extended this concept to describe a condition where two different languages were in use in one community, usually engendering social or educational inequalities.

Since those years, the driving force behind many SLE studies has been to explain and redress social disadvantages that result from linguistic inequalities. The “deficit model” (that certain social or cultural groups may “suffer” from a language deficiency which could be remedied by compensatory education), posited by Bernstein (1971) and his followers, was acclaimed by both British and American scholars who were intrigued by the notion. Through empirical investigations (observation, interviews, and discourse analysis), Bernstein “revealed” that while there was no direct correlation between code choice and social class, there was sufficient evidence (of different levels of elaboration in parent-child discourse) to justify reorganization of schooling to enable students to have broader exposure to different sociolinguistic codes. A similar area of investigation was pursued by Labov (1969) in his seminal work in the USA, which shed light on the contentious topic of cultural and linguistic deficiencies. Through analysis of spontaneous narratives, triggered by elicitation by the researcher, Labov was able to substantiate his argument that speakers of “non-standard English” were neither verbally deprived nor intellectually inferior; they were simply less practiced in adapting their uses of conventional, appropriate linguistic codes.

Sociolinguists in SLE continue to follow many of the patterns of investigation led by Fishman and his contemporaries, but the research questions and methodologies have expanded, addressing educational questions which might be (1) locally situated, as in the linguistic needs of a school district, (2) nationally oriented (e.g., the language education policy of an emerging nation state (see Dei 2010) or the need to investigate and establish the globalization of a nation’s language (see Aldave-Yap 2010)), or (3) have international status, as in policy decisions for a continental educational alliance (McIlwraith 2013). The expansion of the range of methods used for research was seen early on in the increasing adherence to “triangulation” of data collection and analysis and greater attention given to ethnographic processes and approaches (see below).

Fishman, again, led the field in raising awareness of linguistic rights and language loyalty. Much of the work in this area relates to educational processes, whether at the level of medium of instruction in the classroom (see Dei and Asgharzadeh 2003) or state or government policy (Skutnabb-Kangas 2000), be they formal or informal, as in the case of intergenerational family transmission that has been shown to be the basis for reversing language shift. This foundational work has generated an enthusiasm, or thirst, for more of same. As with the abovementioned studies, the employment of quantitative methodologies remains predominant in SLE research on policy

issues and decision-making at a national level (cf. McIlwraith 2013), but over the last 20 years, the field has witnessed increasing employment of an ethnographic research approach with its qualitative methods of data collection and analysis, case study approach, attitudinal studies and face to face interviews and discussions, and a focus on the sociolinguistic aspects of the data. This approach appealed to those who sought deep and increasingly thicker meaning in local sites of inquiry by acquiring the “native” point of view (Duchêne et al. 2013; Henry 1998; Jo 2001). A recent study of the history and the areas of focus of research on language conflict by Darquennes (2015) pays particular attention to a number of selected features of societal language conflict. A discussion of the causes, the visibility, the manifestations, the discursive focal points, the management, and the outcomes of the management of societal language conflict precede a sketch of methodological approaches in language conflict research. The snapshot of language conflict research ends with a list of research desiderata.

The move toward embracing ethnographic approaches reflects the broadening of focus in studies of SLE, concomitant with the advent of critical theories emerging from poststructural, postmodern, and postcolonial thought. This has generated studies that look into “the ways that social relationships are lived out in language and how issues of power. . . are centrally important in developing critical language education pedagogies” (Norton and Toohey 2004, p. 1). Hence, a growing number of research orientations, predominantly qualitative in nature, embrace an “emancipatory” approach (Cameron et al. 1993). Features of such an approach include (1) emic-oriented studies, where the researcher adopts the insider’s point of view (McLaughlin 1992) and is involved in the study both as an informant and an active participant (e.g., Skilton-Sylvester 2002); (2) the democratizing of research, whereby the research subjects are involved in the study in proactive ways such as participatory action research (Muthwii 2004); and (3) more eclectic practices, which embrace both quantitative and qualitative data as their samples or evidence for analysis (e.g., Clyne et al. 2004; Lam and Warriner 2012).

While SLE research methodologies have borrowed from other disciplines, unique approaches and research-based models have also been generated. One such example is the ecological approach. The concept of “language ecology,” originally coined by Haugen (1972), highlights how a language relates to other languages in the environment and the broader social context (Mühlhäusler 2010). In the area of language policy and planning, the term has been used to discuss means for promoting multilingualism and linguistic diversity (Phillipson and Skutnabb-Kangas 1996) and the impact of macro-sociopolitical forces on individual linguistic choices (Ricento 2000). The ecological perspective is used to explore “the inter-relationships between an individual and her/his languages, and across individuals and their languages . . . negotiated through different types of interactions, underpinned by situated and ideological, cultural and political histories” (Creese and Martin 2003, p. 1).

Research that uses an ecological approach thus explores language-related issues and phenomena, keeping in mind learner and societal diversity vis-à-vis political, social, economic, cultural, and linguistic factors, from local to national and in some

cases to global standpoints. This ecological approach was adopted by the Language Policy Unit of the Council of Europe (e.g., see ESTONIA, 2010) when assisting member states and regions to create “Language Education Policy Profiles” via “a process of reflection by the authorities and involving civil society, together with their [Council of Europe] experts” who functioned “as catalysts in this process” (Council of Europe 2014). Through this holistic exercise, the Language Policy Unit facilitated a thorough examination of language practice and policy for each education system, one that took up the challenge (more than 18 states or regions in the European Community produced reports), giving them a language-specific basis on which to focus on possible future policy developments.

---

## Major Current Contributions

Current research reflects the turbulence, change, and perpetual development that the complexities of social life today bring. Globalization and technological development, the emergence of newly dominant communities, local states reasserting their national rights, the aftermath of/recovery from colonization, the development of multinational unions, and the establishment of different power bases at local as well as at governmental levels provide foci for investigation. This is particularly the case where language status and language education are concerned. In this next section, the focus is on language spread and language maintenance in the first part of the twenty-first century, in relation to globalization and the impact on formal education. Examples are given of the range of research paradigms that were employed.

The transnational mobility of individuals, goods, and services, along with the diffusion of mass information via telecommunications, has reshaped the SLE research agenda in recent years. The spread of English, the emergence of postcolonial New Englishes (Jenkins 2003), and the struggle for language maintenance in the face of English dominance have prompted research with far-reaching consequences on macrolinguistic and educational policy decisions, on micro classroom issues, and on the interaction between the two. An example is Dei and Asgharzadeh’s (2003) ethnographic and critical examination of the ramifications of “imposed languages” on schooling issues in two different sites: the status of Farsi in Iran and English dominance in post-colonized Ghana. Their case studies are built on the evidence gained from interviews, observational and recorded evidence of language behavior, attitudes and practices, examination of documentation, and official reports, plus discussion and critique. Empirically derived data enabled them to give account of the power of language use and the effects of its empowerment attributed to corporate globalization. In other areas, this same “threat” of English hegemony has generated studies of trilingual and quadrilingual language programs (especially in bilingual European contexts such as the Basque, Catalan, Sweden, and Friesland), where English is studied as the third or additional language (Cenoz 2009; Cummins 2001).

One of the outstanding global phenomena in language instruction and research is the evolution of new communication technologies, their environments, and

pedagogies (Belz 2002; Thorne and Payne 2005), creating options in both the area of research method (data collection and analysis options; see below) and communicative traits (media genres). Among the SLE research concerns are language contact and environment on the Internet (Holmes 2004) and intercultural communication. Kern et al. (2004) noted the shift in research topics from networked language learning in classrooms to collaboration projects conducted online allowing for broader social discourse and intercultural competence. Belz (2002), for example, using methodology grounded in social realism – “any human activity is thought to be shaped by both macro- and micro-level sociological features” (p. 60) – examined the interaction online (*tele-collaboration*) between American students (learners of German) and university students in Germany. Belz’s work embodies the essence of SLE in the new era, bringing together the elements of language contact and learning environments along with an examination of posited intercultural communication.

The roles that speakers play have long been a focus in SLE studies, but with the increase in transmigration and language spread, the notion of native speaker concepts and privileges, and the resources afforded the native speaker of the central versus peripheral English varieties (Brutt-Griffler 2002), has given rise to a new research perspective in SLE: the relevance and respective merits of language teachers who are either native or nonnative speakers of the language they teach. The search for insight into teachers’ perceptions (on how they are perceived by others), their self-efficacy and effectiveness, draws on data collected via both quantitative and qualitative methodology (with often a mixture of both), thus allowing for a multi-angled representation of the examined phenomena (see the edited volume on nonnative English teachers by Llorca 2005).

Prevalent among recent studies are those concerned with the maintenance or reversal of indigenous languages (cf. Dei and Asgharzadeh 2003), the maintenance of heritage languages, and language spread, as they relate to the medium and the content of instruction and the power of education to effect change. Many manifest the social activist attitude of SLE researchers who were not content to study a topic without being involved in a proactive manner (cf. Cameron et al. 1993). Some of the cited work herein is avowedly interventionist (Cooper and Maloof 1999; Muthwii 2004), while others are participatory, being ethnographic (Adegbite 2003, see below) or action research studies (Nagai and Lister 2003). The diverse methodologies employed to investigate, explain, or perhaps advocate reflect the multilingual – and multidimensional – communities in the complex sociolinguistic and socioeducational situations that exist today in the globalized environment.

We still, however, find studies that adhere to a single research method (see, also, below) such as quantitative analysis of census data. For example, MacKinnon (2004) employed empirical analysis of census data regarding Celtic languages to demonstrate that reversal of a downward trajectory could be achieved through sustained instruction. Likewise Lasagabaster (2000) analyzed standardized test data to investigate the preferred and most efficacious type of multilingual education in secondary schooling in the Basque area. However, the majority of the studies incorporate a variety of data from a range of sources. Muthwii (2004), for example, used official government records, questionnaires, and interviews to compare a community’s

perceptions of mother tongue use in schooling with that of official policy and the stated medium of instruction. Ejieh's (2004) ethnographic work in Nigeria explored participants' perceptions of the indigenous tongue (as medium of instruction) as an instrument for social and economic advancement in light of the growing power of English as an international lingua franca. In many postcolonial nations, the status of indigenous language(s) is threatened considerably by English and other former colonial languages (Dei and Asgharzadeh 2003). A proactive effort was effected by Adgebite (2003), who engaged in participatory action research attempting to raise awareness of the importance of indigenous language maintenance by conducting a course of progressive "enlightenment" on this topic for an elite group of students. Others have tried to redress a situation of threatened language loss (with a modicum of success) by introducing culturally relevant topics into modes of instruction (see Henry 1998; Nagai and Lister 2003) or engaging in ethnographic study interactively with the subjects of one's study McCarty (2015) and see this volume.

---

## Challenges and Problems

Now into the second decade of the new millennium, we see many manifestations of the broader approaches to research methodology that began with adherence to the value of triangulation of data. Researchers are moving further into the mixed-method "camp" (MMR) which proponents consider the preferred mode for investigating or accounting for sociolinguistic issues, be they macro-societal phenomena, such as maintenance of indigenous languages in a postcolonial region, or micro-oriented issues such as learner identity in a second language environment. Despite this, though the field employs diverse research methodologies, there remains an abiding perceived dichotomy between the value of quantitative and qualitative research paradigms (Lazaraton 2005). Indeed, we should be aware of arguments where under certain circumstances, a single method research mode may be preferable. While acknowledging that MMR may yield important benefits – such as uncovering related insights or improving the coding of variables – Ahmed and Sil (2012), focusing on MMR that combines some type of qualitative analysis with statistical or formal approaches, call for a balanced "and nuanced understanding" of what the array of choices may bring. They advocate that collaborative research be conducted, where each scholar competently deploys his/her own method, achieving "distinctive insights" of research to produce, collectively, coherent findings. Several examples of this "collective" type of investigation quoted herein attest to this suggestion, but it cannot be mandated as a criterion for valuable study that MMR only be conducted by conglomerates.

Clearly, it is the research purpose that should guide the choice of methodology (rather than vice versa) in order to allow researchers to find the answers to "burning critical questions about social life" rather than restrain them (Shohamy 2004, p. 732). Furthermore, concern over adherence to specific methodologies potentially might divert attention from the primacy and robustness of the underlying theory for the research (Cummins 1999). An approach which addresses this concern is that of

Rampton et al. (2002, 2014), who proposed a breaking down of assumptions that paradigms dictate in favor of an interdisciplinary collaborative approach to the examination of contemporary urban language, learning, and interaction. The gradual emergence and recognition of alternative research paradigms is also applicable to the role and required qualifications of researchers. Practitioner research, in the form of reflective action research, was once considered a less-than-scholarly enterprise but has now achieved almost equal status in the eyes of the research community (Burns 2005).

The Action Research mode of inquiry is increasingly employed in SLE-oriented studies enabling interested, committed scholars to be proactively involved in their studies. One avenue is that of maintaining linguistic diversity which despite the rapid decline of many languages in this new millennium is still widespread, with many urban areas boasting a plethora of different home languages. Progressive educational authorities strive to meet the needs of diverse communities to accommodate the use and maintenance of home tongues (or heritage languages) by incorporating some system of bi- or multilingual education. Proactive efforts to this end are exemplified in the large-scale action research of Clyne et al. (2004), a study which involved teachers, school students, and curriculum organizers in promoting the study of community languages as second or third languages. An attempt to redress the loss of heritage tongue through medium of instruction is recounted by Cooper and Maloof (1999) who conducted participatory action research involving native-speaking parents in teaching elementary-level Chinese, Japanese, and Korean in a US school. Jo's ethnography (2001) of diasporic cultural identity (of Korean American women in the USA) and maintenance of heritage language exemplified a different yet still significant aspect of the situation: investigating attitudes and identity with regard to heritage and other tongues.

---

## Future Directions

Future SLE research will continue to respond to the impact of current developments on education. Issues that will demand attention include first language literacy and modes of bilingual education, with the concomitant development of the acceptance of translanguaging (Garcia 2009; Jonsson 2013; Makalela 2015); in micro and macro terms, identity issues of language learners and their teachers are of relevance to society at large and to local sites of interest (see above, Lurda 2005). A growing area of attention is the role of language shift and language maintenance in second and third language early childhood education (Cenoz 2009) and the language education policies of developing countries and emergent states where policies have yet to be established successfully or heritage languages have yet to become stabilized. In-depth, qualitative research modes are appropriate for examining the implications and outcomes of different multilingual education alternatives for different communities (indigenous, immigrant or migrant, multi-generational, or single family units). Other important areas of inquiry include the experiences of refugee and immigrant language users and learners in acquiring needed life skills and

schooling, the possibilities of adult education in their adopted language (Warriner 2004), and the participatory and hence emancipatory approach gaining popularity in critical ethnographic work (Warriner 2012).

The prediction that future research would likely see an increased utilization of communication technology affording scholars' massive worldwide data collection, instantaneous data analysis, and direct public accessibility has come to pass. A fear was expressed that communication technology might also have adverse effects on the research process due to the relative ease of placing accessible research tools in cyberspace for use by the wider public or for specific groups. This fear has now been allayed, although scholars asserted that such practice needed to be treated with caution, for while opening new avenues for data collection on an immediate and large scale, it might also lead to research abuse if rigor and quality-control measures, for example, in terms of sampling, were not maintained (Lu and Shulman 2008). The availability of data resources and means of analysis in the cyber world today affords researchers wide opportunities for individual and collaborative study. There is, however, an abiding need for more participatory studies, where every stakeholder (researcher, native speaker informant, or case study subject) has a voice, representing their identity and their values. As Corson (2001) asserted, the school should be the locus of language in education policy. Granting of agency to the less powerful is a central aim of the emancipatory approach. Such an approach can be applied to both pressing local and more global SLE issues which concern us today.

---

## Cross-References

- ▶ [Censuses and Large-Scale Surveys in Language Research](#)
- ▶ [Ethnography of Language Policy](#)
- ▶ [Investigating Language Education Policy](#)
- ▶ [Researching Language Loss and Revitalization](#)
- ▶ [Second Language Acquisition Research Methods](#)
- ▶ [Theoretical and Historical Perspectives on Researching the Sociology of Language and Education](#)

---

## Related Articles in the Encyclopedia of Language and Education

Nelson Flores and Jeff Bale: [Sociopolitical Issues in Bilingual Education](#). In Volume: Bilingual Education

---

## References

- Adegbite, W. (2003). Enlightenment and attitude of the Nigerian elite on the roles of languages in Nigeria. *Language Culture & Curriculum*, 16(2), 185–196.
- Ahmed, A., & Sil, R. (2012). When multi-method research subverts methodological pluralism – Or, why we still need single-method research. *Perspectives on Politics*, 10(4), 935–953.



- Aldave-Yap, F. (2010). Global Filipino in multilingual education. <https://larc.sdsu.edu/images/larc/yap-global-filipino-in-multilingual-education.pdf>. Accessed 18 Aug 2015.
- Belz, J. A. (2002). Social dimensions of tele-collaborative foreign language study. *Language Learning & Technology*, 6(1), 60–81.
- Bernstein, B. (1971). *Class, codes and control: Theoretical studies towards a sociology of language* (Vol. 1). London: Routledge.
- Brutt-Griffler, J. (2002). *World English: A study of its development*. Clevedon: Multilingual Matters.
- Burns, A. (2005). Action research. In E. Hinkley (Ed.), *Handbook of research in second language teaching and learning* (pp. 241–256). Mahwah: Lawrence Erlbaum Associates.
- Cameron, D., Frazer, E., Harvey, P., Rampton, B., & Richardson, K. (1993). Ethics, advocacy and empowerment: Issues of method in researching language. *Language & Communication*, 13(2), 81–94.
- Cenoz, J. (2009). *Towards multilingual education: Basque educational research from an international perspective* (Vol. 72). Bristol: Multilingual Matters.
- Clyne, M., Rossi Hunt, C., & Isaakidis, T. (2004). Learning a community language as a third language. *The International Journal of Multilingualism*, 1(1), 33–52.
- Cooper, R. (1989). *Language planning and social change*. Cambridge: Cambridge University Press.
- Cooper, T. C., & Maloof, V. M. (1999). Parent involvement in teaching elementary-level Chinese, Japanese, and Korean. *The Journal of Educational Research*, 92(3), 176–183.
- Corson, D. (2001). *Language diversity and education*. Mahwah: Lawrence Erlbaum Associates Publishers.
- Council of Europe. (2014). Education and languages, language policy. [http://www.coe.int/t/dg4/linguistic/Profils\\_en.asp](http://www.coe.int/t/dg4/linguistic/Profils_en.asp)
- Council of Europe, Language Education Division. (2010). *ESTONIA*. Estonian Ministry of Education and Research Language Policy Division, Strasbourg. [www.coe.int/t/dg4/linguistic/Source/Profile-Estonia\\_EN.doc](http://www.coe.int/t/dg4/linguistic/Source/Profile-Estonia_EN.doc)
- Creese, A., & Martin, P. (2003). *Multilingual classroom ecologies: Inter-relationships, interactions and ideologies*. Clevedon: Multilingual Matters.
- Cummins, J. (1999). Alternative paradigms in bilingual education research: Does theory have a place? *Educational Researcher*, 28(7), 26–32.
- Cummins, J. (2001). *Negotiating identities: Education for empowerment in a diverse society* (2nd ed.). Los Angeles: California Association for Bilingual Education.
- Darquennes, J. (2015). Language conflict research: A state of the art. *International Journal of the Sociology of Language*, 2015(235), 7–32.
- Dei, G. J. S. (2010). *Teaching Africa: Towards a transgressive pedagogy*. New York: Springer.
- Dei, G. J. S., & Asgharzadeh, A. (2003). Language, education and development: Case studies from the Southern contexts. *Language and Education*, 17(6), 421–449.
- Duchêne, A., Moyer, M., & Roberts, C. J. (2013). *Language, migration and social inequalities: A critical sociolinguistic perspective on institutions and work*. Clevedon: Multilingual Matters.
- Ejeh, M. U. C. (2004). Attitudes of students and teachers towards teaching in mother tongue in Nigerian primary schools: Implications for planning. *Language, Culture and Curriculum*, 17(1), 73–89.
- Ferguson, C. A. (1959). Diglossia. *Word*, 15, 325–340.
- Fishman, J. A. (1971). The sociology of language: An interdisciplinary social science approach to sociolinguistics. In J. A. Fishman (Ed.), *Advances in the sociology of language*. The Hague: Mouton.
- Fishman, J. A. (1991). *Reversing language shift (RLS): Theoretical and empirical foundations of assistance to threatened languages*. Clevedon: Multilingual Matters.
- Fishman, J. A. (Ed.). (2001). *Can threatened languages be saved?: Reversing language shift, revisited: A 21st century perspective* (Vol. 116). Clevedon: Multilingual Matters.
- Garcia, O. (2009). Education, multilingualism and translanguaging in the 21st century. In T. Skutnabb-Kangas (Ed.), *Social justice through multilingual education* (pp. 140–158). Clevedon: Multilingual Matters.

- Gumperz, J. J. (1968). Types of linguistic communities. In J. Fishman (Ed.), *Readings in the sociology of language* (pp. 460–472). The Hague: Mouton.
- Haugen, E. (1972). *The ecology of language*. Stanford: Stanford University Press.
- Henry, A. (1998). *Taking back control: African Canadian women teachers' lives and practice*. Albany: State University of New York Press.
- Henze, R., & Davis, K. (1999). Introduction: Authenticity and identity: Lessons from indigenous language education. *Anthropology & Education Quarterly*, 30(1), 3–21.
- Holmes, H. K. (2004). An analysis of the language repertoire of students in higher education and their language choices on the Internet (Ukraine, Poland, Macedonia, Italy, France, Tanzania, Oman and Indonesia). *International Journal on Multicultural Societies*, 6(1), 29–52.
- Jenkins, J. (2003). *World Englishes*. London: Routledge.
- Jo, H.-Y. (2001). Heritage' language learning and ethnic identity: Korean Americans' struggle with language authorities. *Language Culture and Curriculum*, 14(1), 26–42.
- Jonsson, C. (2013). Translanguaging and multilingual literacies: Diary-based case studies of adolescents in an international school. *International Journal of the Sociology of Language*, 2013(224), 85–117.
- Kern, R., Ware, P., & Warschauer, M. (2004). Crossing frontiers: New directions in online pedagogy and research. *Annual Review of Applied Linguistics*, 24, 243–260.
- Labov, W. (1969). The logic of non-standard English. In *Georgetown monographs on language and linguistics* (Vol. 22). Washington, DC: Georgetown University.
- Lam, W. S. E., & Warriner, D. S. (2012). Transnationalism and literacy: Investigating the mobility of people, languages, texts, and practices in contexts of migration. A review of research. *Reading Research Quarterly*, 47(2), 191–215.
- Lasagabaster, D. (2000). Three languages and three linguistic models in the Basque educational system. In J. Cenoz & U. Jessner (Eds.), *English in Europe: The acquisition of a third language* (pp. 179–197). Clevedon: Multilingual Matters.
- Lazaraton, A. (2005). Quantitative research methods. In E. Hinkley (Ed.), *Handbook of research in second language teaching and learning* (pp. 209–224). Mahwah: Lawrence Erlbaum Associates.
- Llurda, E. (Ed.). (2005). *Non-native language teachers: Perceptions, challenges, and contributions to the profession*. Boston: Springer.
- Lu, C.-J., & Shulman, S. (2008). Rigor and flexibility in computer-based qualitative research: Introducing the coding analysis toolkit. *International Journal of Multiple Research Approaches*, 2008(2), 105–117.
- MacKinnon, K. (2004). Language shift: Celtic languages today—any evidence? *Journal of Celtic Languages*, 8(1), 109–132.
- Makalela, L. (2015). Translanguaging practices in complex multilingual spaces: A discontinuous continuity in post-independent South Africa. *International Journal of the Sociology of Language*, 234, 115–132.
- McCarty, T. (2015). Ethnography in language planning and policy research. In F. Hult & D. C. Johnson (Eds.), *Research methods in language policy and planning: A practical guide* (pp. 81–93). West Sussex: Wiley.
- McIlwraith, H. (Ed.). (2013). *Multilingual education in Africa: Lessons from the Juba language-in education conference*. London: British Council.
- McLaughlin, D. (1992). *When literacy empowers: Navajo language in print*. Albuquerque: University of New Mexico Press.
- Mühlhäusler, P. (2010). Language planning and language ecology. *Current Issues in Language Planning*, 1(3), 306–367.
- Muthwii, M. (2004). Perceptions of parents, pupils and teachers on the use of mother tongue: Kiswahili and English in primary schools. *Language Culture and Curriculum*, 17(1), 15–293.
- Nagai, Y., & Lister, R. (2003). What is our culture? What is our language? Dialogue towards maintenance of indigenous culture and language in Papua New Guinea. *Language and Education*, 17(2), 87–104.

- Norton, B., & Toohey, K. (2004). *Critical pedagogies and language learning*. Cambridge: Cambridge University Press.
- Phillipson, R., & Skutnabb-Kangas, T. (1996). English only worldwide or language ecology. *TESOL Quarterly*, 30(3), 429–452.
- Rampton, B., Maybin, J., Roberts, C. (2014). Methodological foundations in linguistic ethnography Paper 125 in *Working Papers in Urban Language & Literacies*. London: King's College. <http://www.kcl.ac.uk/sspp/departments/education/research/lc/publications/workingpapers/the-papers/WP125-Rampton-Maybin-Roberts-2014-Methodological-foundations-in-linguistic-ethnography.pdf>
- Rampton, B., Harris, R., Leung, C., & Roberts, C. (2002). Methodology in the analysis of classroom discourse. *Applied Linguistics*, 23(3), 373–392.
- Ricento, T. (2000). Historical and theoretical perspectives in language policy and planning. *Journal of Sociolinguistics*, 4(2), 196–213.
- Shohamy, E. (2004). Reflections on research guidelines, categories and responsibility. *TESOL Quarterly*, 38(4), 728–731.
- Skilton-Sylvester, E. (2002). Literate at home but not at school: A Cambodian girl's journey from playwright to struggling writer. In G. Hull & K. Schultz (Eds.), *School's out!* (pp. 61–92). New York: Teachers' College Press.
- Skutnabb-Kangas, T. (2000). *Linguistic genocide in education or worldwide diversity and human rights*. Hillsdale: Erlbaum.
- Thorne, S. L., & Payne, J. S. (2005). *Internet-mediated text and multi-modal expression in foreign language education* (CALPER working papers series, Vol. 5). Philadelphia: The Pennsylvania State University.
- Warriner, D. (2004). The days now is very hard for my family: The negotiation and construction of gendered work identities among newly arrived women refugees. *Journal of Language, Identity, and Education*, 3(4), 279–294.s.
- Warriner, D. S. (2012). When the macro facilitates the micro: A study of regimentation and emergence in spoken interaction. *Anthropology and Education Quarterly*, 43(2), 173–191.

---

# Researching Globalization of English

Joseph Sung-Yul Park

---

## Abstract

Research on the globalization of English – how the English language, no longer the language of the Anglo-Saxons, spread throughout the British Isles, colonies of the English-speaking empires, and the rest of the world, to gain the status of a global language, spoken by more and more people around the world – has developed through various methodologies that focused on the form, function, and ideologies of English. Over the past several decades, a wide range of methods has been employed, ranging from structural description to corpus analysis, from sociological analysis of domains to analysis of media texts, from matched guise technique to ethnographic and interactional analysis. But recent studies, due to the influence of poststructuralist perspectives on language, have increasingly questioned the implication that each of the three aspects of form, function, and ideology can be separately investigated on its own. An increasing number of studies thus shift their attention from nation-states to communities and abandon the assumption of fixed and predefined language boundaries to focus on speakers' translingual practices as they draw upon multiple linguistic resources. Since the global spread of English is deeply implicated in the relations of power and inequality characteristic of neoliberalism, future innovations are likely to come from interdisciplinary perspectives that strive to move beyond the traditional scope of linguistics and language study toward interfaces with social dimensions that can illuminate the practical conditions of English in the world, such as language and materiality, or language and desire.

---

J.S. Park (✉)

Department of English Language and Literature, National University of Singapore, Singapore, Singapore

e-mail: [ellpjs@nus.edu.sg](mailto:ellpjs@nus.edu.sg)

---

**Keywords**

 English • Globalization • Form • Function • Ideology • Research methods
 

---

**Contents**

Introduction .....	28
Early Developments .....	29
Major Contributions .....	30
Form .....	30
Function .....	31
Ideologies .....	32
Work in Progress .....	33
Problems and Difficulties .....	35
Future Directions .....	35
Cross-References .....	36
Related Articles in the Encyclopedia of Language and Education .....	37
References .....	37

---

**Introduction**

Globalization of English here refers to the process by which the English language, no longer the language of the Anglo-Saxons, spread throughout the British Isles, colonies of the English-speaking empires, and the rest of the world, to finally gain the status of a global language, learned and spoken by more and more people around the world, a lingua franca that allows people from different corners of the world to communicate with each other. As a phenomenon that has a significant influence on the world, it has been a key issue for research on language and education. But because it is such a broad and complex phenomenon that involves multiple dimensions, including linguistic, social, cultural, and political ones, the research methods that have been employed to investigate the global spread of English have been extremely diverse. Indeed, it would not be an overstatement to say that there is no method for exploring language in social context that has not been adopted for the study of the globalization of English. This chapter, which reviews the research methods for the global spread of English, is thus necessarily selective; instead of offering a comprehensive picture of the widely diverse approaches adopted in the investigation of this phenomenon, it provides an overview of some of the major methodological perspectives that the field has employed in past and contemporary research. For this purpose, the discussion here centers on three different directions of research – approaches that focus on the form, function, and ideologies of English, respectively. It must be noted that this three-way distinction is not meant to be a categorization of the work of individual researchers or particular research traditions, as specific research projects in the globalization of English often deal with more than one of these three dimensions simultaneously; instead, the consideration of the form, function, and ideologies of English as a global language is meant to highlight the range of research methods that have been employed in the study of this phenomenon and to explore their implications for future research (for a more comprehensive review, see Berns [2012](#); Bolton [2005](#)).

## Early Developments

Bolton (2005) identifies the earliest contributors to the study of the globalization of English as coming from several different fields of research. Some such as Quirk (1962) came from the field of English studies, with a background in the philology and history of English; others such as Joshua Fishman (Fishman et al. 1977), associated with the field of sociology of language, came from educational psychology and sociology; Trudgill and Hannah (1982) came from sociolinguistics, with an emphasis on the variationist framework; and Kachru (1982), who started the major field of world Englishes research, took a broadly sociolinguistic approach that focused on language contact and social functions of language. Though different in their emphases, these works generally attempted to establish the globalization of English as a new and distinct field of research by drawing attention to the growing diversity of English and its shifting roles and positions in the world.

These studies had several consequences. First, they clearly established the notion of multiple “Englishes”; they demonstrated how the English language cannot be seen as a single “variety,” but made up of multiple “varieties,” each with its unique and systematic structure, legitimate in its own right. Though this pluralization of English into “Englishes” was, as we will see below, later problematized, there can be no doubt about the impact of this conceptual shift. In terms of research methods, in particular, structural linguistic description of new varieties of English – describing their phonology, morphosyntax, lexicon, and pragmatics – became a key dimension of studying the globalization of English (Kachru 1983; Platt et al. 1984; Trudgill and Hannah 1982).

Second, they highlighted the shifting functions of English as it became not only the language of a handful of English-speaking countries but also a global language that is used and adopted across many different countries and domains. If it was previously assumed that English was purely a language of what Kachru (1985) identified as inner circle countries, it was now becoming unsurprising to find English showing up in the “distant” places of Africa or Asia. A major methodological impetus this led to, then, was to investigate the shifting functions of English in the world in terms of its macro-social distribution. Tracking the growth of numbers of English speakers across the world, the insertion of English into patterns of multilingualism in different societies and the expansion of sociolinguistic domains associated with English became a key methodological approach (Fishman et al. 1977).

Third, the ideological challenge that such studies brought to the received order of linguistic legitimacy was significant. Many of the above researchers clearly aimed to problematize and contest the idea that such new varieties of English were merely learner errors or deviant forms of language where English is haphazardly mixed with local languages. By foregrounding the systematicity, creativity, and local adaptability of English, they tried to present new Englishes as legitimate varieties in their own right, thus questioning the implied authority of Standard English based on norms of the “center,” understood to be represented by the inner circle. While the ideological critique of English as a global language was not made explicit as a research methodology until late in the 1990s when frameworks such as linguistic imperialism

(Phillipson 1992) and critical applied linguistics (Pennycook 2001) appeared, earlier contributions did set the stage by identifying the broad political stance that most researchers would adopt – that research on the globalization of English would support and defend the legitimacy of new Englishes by demonstrating their systematicity and adaptability.

---

## Major Contributions

Our discussion above shows how early developments in the field have focused on three particular aspects of the globalization of English for its methodological basis: the form, function, and ideologies of English as a global language. It was along these three dimensions that various methodological approaches were adopted to further the research on the globalization of English. In this section, we look at the specific methodological frameworks and tools that were employed in later research that built upon each of these dimensions.

### Form

Linguistic description of new varieties of English continued to be a prominent contribution in linguistic research. As noted above, this line of research adopted linguistic analysis as its basis, offering structural descriptions in terms of lexis, phonology, morphosyntax, and pragmatics, to characterize the variation and diversity that exist among new varieties of English. The work accumulated over the past several decades is now substantial, including large reference volumes such as Kortmann and Schneider (2004), book series such as *Varieties of English Around the World*, and numerous articles in the journals *World Englishes* and *English World-Wide*.

Research focused on linguistic form does not only involve synchronic description of a single variety but also work that derives from the perspective of language contact. In this line of work, features of new varieties of English are seen as arising from the mutual influence between English and other language varieties, and linguistic analysis is employed to trace such influences to understand the development of new Englishes. For instance, Ho and Platt (1993) account for the continuum among subvarieties of Singaporean English used by Chinese Singaporeans in terms of contact with language varieties such as Chinese languages and Baba Malay. Research building upon contact linguistics can also take on a more historical perspective, considering patterns of contact between English-speaking colonizers and the local indigenous population as key factors for shaping the development of English. Schneider's (2003, 2007) work attempts to build a general model for the evolution of new varieties of English by consolidating the normative patterns of contact situations in colonial context where English served important communicative roles.

Another important research method that has been employed in the structural description of English as a global language is that of corpus linguistics. Building corpora of national-level varieties for purposes of lexicography or grammatical description has been significant in the study of varieties of English. One of the major projects in this direction is the International Corpus of English (ICE), which since the late 1980s has been gathering one million words of spoken and written English texts in the local varieties of countries or regions including Australia, New Zealand, Kenya, Tanzania, Hong Kong, India, Jamaica, the Philippines, Malaysia, and Great Britain. The development of such large parallel corpora has significant methodological implications for the structural studies of English, as it allows for more systematic analysis of similarities and differences in linguistic structure across varieties (Greenbaum 1996). But it is not just comparison across varieties that makes corpus-based research useful. The Vienna-Oxford International Corpus of English (VOICE) led by Seidlhofer (2010) has compiled one million words of spoken interaction among nonnative speakers across different contexts in order to explore how people use English in lingua franca situations. The methodological implication here is that it allows researchers to identify specific areas of communicative problems that might occur in such mode of communication and to make practical suggestions for facilitating greater mutual understanding.

## Function

The shifting function of English in the world has been actively studied by observing macro-social patterns and their correlations with the global spread of English. The approach of sociology of language was most directly involved in such mode of research. For instance, adopting statistical tools and building upon a large body of secondary sources, Fishman et al. (1977) try to identify various social factors that can best predict the establishment of English as an “additional language” in non-English mother tongue societies. The factors they investigate include experience of colonial rule, linguistic diversity, degree of material incentives gained by learning English, urbanization, economic development, educational development, religious composition, and political affiliation of the society.

While the attempt at large-scale predictions relying on statistical tools was not necessarily inherited in later research, the investigations of the role of macro-social factors and political relations that contribute to the spread of English remained a key concern for many studies, especially those in language policy and planning. For instance, Tollefson’s (1991) historical-structural approach to language policy critically examines the institutional conditions of investment in English language learning in countries like Iran and China to reveal how they work to reproduce barriers that inhibit the economic and political development of those countries. Studies that attempt to chart the macro-scale future trajectory of English as a global language still continue, however, through the work in the “futurology” of English. Most clearly represented by the work of Graddol (1997, 2006), this direction of research combines analysis of social, economic, and cultural trends with computer modeling of



demographic data to predict what the future status of English will be. For instance, Graddol (2006) forecasts a near future in which the market for English language learning will be saturated, leaving only young children and students with learning disabilities as the pool of new English learners.

Other studies focus on understanding the function of English within specific cultural or discursive domains. One productive area of research in this direction is the study of English in the media. Bhatia (1987), Piller (2001), and Martin (2002) are some representative examples of studies that look at the patterns in which English is used along with other languages in commercial advertisements. By analyzing the relative distribution of English and other languages within the text, these studies identify the different social meanings attributed to English and the social identities it projects for the audience as consumers. Another example is studies that adopt the framework of linguistic landscapes, a recently developed subfield of sociolinguistic research that focuses on the analysis of language use in public signage (Bolton 2012; Rowland 2016). Again, the exploration of the relative distribution of visible English in such public spaces not only offers an account of the extent of the spread of English in different societies but also reveals the shifting functions and cultural meanings of English.

## **Ideologies**

Investigating local speakers' perceptions of English and how they relate to the acceptance of or resistance toward English has been a key method employed in the study of the globalization of English from early on. For instance, Fishman et al. (1977) used typical tools (i.e., questionnaires, interviews, and matched guise tests) for language attitude research to understand the perceptions of speakers in countries including Israel and Rhodesia, such as their feelings about English and speakers of English and their motivations for learning English. Such approaches, based on methods of social psychology, were useful in gathering information on speakers' perceptions of English in a controlled manner. But later studies came to see those methods, which tend to treat such perceptions as a matter of individual's inner psychological evaluations, as restricting, for they recognized that evaluations and beliefs about the value of English in relation to other languages are much more deeply rooted in social relations of power (e.g., Pavlenko 2005). As a result, there was a gradual shift from investigation of language attitudes to language ideologies, which also implied a shift in research methods.

Critical studies of the global spread of English were most influential in this shift. Phillipson's (1992) work on linguistic imperialism not only investigates the historical and political economic conditions that reproduce the hegemony of English but also identifies linguistic imperialist arguments (i.e., the ideological ways through which the power and hegemony of English is rationalized and sustained) through analysis of academic and institutional discourse about English as a global language.

Similarly, Pennycook (1998), while avoiding the term “ideology” in favor of “discourse,” explores how ideological distinctions between self and other constructed through colonial texts such as travel writing lead to reproduction of inequalities in English language teaching, as the nonnative English learner is constantly positioned as backward, irrational, passive, reluctant, and incompetent.

If the influential critical studies of researchers like Phillipson and Pennycook were grounded on historical and textual data, more recent work has increasingly been adopting ethnographically and interactionally oriented analyses of language ideologies. For instance, Henry (2010) investigates the ideological construction of “Chinglish” – a label used to depict the incorrect and often nonsensical local variety of English in China – by carefully investigating what kind of English gets labeled as Chinglish and what kind of speaker gets associated with Chinglish. His close observation of the metadiscursive practices of language scholars, foreign visitors, foreign English language teachers, and local English language learners reveals that Chinglish cannot be defined in terms of specific linguistic features at all; rather, it functions as an interpellative term that is used to denounce the linguistic legitimacy of Chinese English speakers and to reify the authority of native speakers. Park (2009), on the other hand, identifies ideologies of English from the interactional practices of Korean speakers engaged in metalinguistic talk about English. Seemingly mundane practices such as sequentially delaying occasions to display one’s competence in English can reveal important underlying beliefs that speakers hold about English, for instance, their belief that Koreans can only be illegitimate speakers of English who must defer to the authority of native speakers in judging the validity of linguistic expressions in English.

---

## Work in Progress

While we saw how the three aspects of form, function, and ideologies of English provided methodological directions for the research on the globalization of English, recent developments have increasingly problematized the implication that these three aspects can be explored separately. Particularly influential here were poststructuralist views on language, which led to fundamental rethinking about language, identity, culture, and power, ideas that had constituted the key basis for earlier research. If in the traditional view, language was commonly understood as having a clearly delineable boundary and stable structure and inherently associated with particular identities and cultures understood in essentialist ways, poststructuralist thought questioned this understanding, viewing language as rooted in social practice rather than rigid structure. From this perspective, what we view as grammar is sedimentations of recurrent patterns of language use, and language is always in flux, constantly being reproduced and transformed through language users’ engagement with conditions and material realities of social life. Likewise, identity, culture, and power do not exist as a priori categories but are outcomes of discursive practices

(Park and Wee 2012). The implication for research on the globalization of English is that the English language is not so much a preexisting entity that is simply transplanted across the world, evolving into multiple subvarieties; it resides in the way speakers across the world use various semiotic resources to engage in everyday activities and refashion themselves in different ways. Relevant here is the notion of performativity, in which identities associated with English are not pre-given but constructed, negotiated, and reconstituted through the use of English (Pennycook 2007).

This theoretical perspective had significant implications for research methods, which are reflected in various current projects. First, it has led to a shift of focus away from nation-states and varieties to communities and practices. As we have seen above, the predominant focus of earlier research has been to describe the systematicity of national-level varieties of English. In this case, the internal variation that exists within the boundaries of a country was often ignored, and a normative variety of English that represents the use of English within that country was commonly posited. In this sense, such work had the inherent problem of unwittingly reproducing the monolithic image of English, as it did not question the ideologically constituted entity of English itself and only pluralized it in terms of national-level varieties of English. In contrast, new studies informed by the poststructural perspective shift their attention toward communities, understanding them not as bounded, homogeneous collectivities of speakers, but as a network of language users whose shared practices provide a basis for negotiations of identities. This methodological shift is evident, for example, in Pennycook's (2007) research on global hip-hop, which does not start from a predefined community of speakers but traces the linguistic resources of rap and hip-hop (including appropriations of English) as they are circulated transculturally, to be used in different yet interconnected ways by hip-hop artists around the world to perform and refashion their identities.

Second, questioning of a priori boundaries between languages has foregrounded research methods that can properly address the flexible and dynamic ways in which speakers appropriate linguistic resources from multiple sources. This can be seen in several lines of research. Research on lingua franca English adopts an interactional approach to study the way multilingual speakers consider English not as a unified system but as part of the pool of resources they can draw upon to negotiate meaning in conversation, a practice often identified as translanguaging (García 2009). Canagarajah (2013), for instance, relies on concepts from interactional sociolinguistics (including framing and footing) to analyze the translanguaging practices that speakers use in communication mediated by English as a lingua franca. Leimgruber (2012), in contrast, employs the sociolinguistic notion of indexicality to account for Singapore English speakers' flexible shift between styles of local English. Instead of attempting to analyze stylistic variation by positing distinct varieties (e.g., Standard Singapore English vs. Colloquial Singapore English), Leimgruber focuses on the indexical meaning that each individual linguistic feature might evoke in interactional context, explaining variation in terms of speakers' acts of stance-taking as they participate in interaction.

---

## Problems and Difficulties

The discussion above shows how methods for research on the globalization of English have evolved to more appropriately deal with the nature of language as complex and fluid practice, rather than a fixed and bounded entity. Yet many challenges remain. Globalization of English is an important topic of research in our age not only because it is such a prominent phenomenon but also because it is an issue closely intertwined with massive problems of power and inequality. The history of the global spread of English is a history of imperial conquest, and while it is often argued that with the retreat of colonialism English has also lost its imperial implications, clearly English is still a crucial resource through which global level relations of inequality are reproduced, for instance, through the persistent hierarchical opposition between native and nonnative speakers of English. Particularly in the context of neoliberalism (Block et al. 2012), in which English is widely promoted as a necessary language of global opportunity and material success, such inequalities are only exacerbated. This calls for new perspectives on English as a global language that can effectively critique such problems of inequality and seek alternative possibilities, as well as research methods that can bring such perspectives into full fruition (May 2014).

While these issues have been raised before (for instance, Park and Wee 2012), there still needs to be greater methodological innovations that can integrate poststructuralist perspectives on language with critical examination of the power of English in the capitalist economy. For instance, while interactional approaches adopted by studies on translanguaging are effective in helping us avoid and contest a priori linguistic boundaries, they tend to highlight the linguistic creativity and adaptability of individual speakers, and as a result, the question of how such translanguaging practices relate to the reproduction or problematization of the global level hegemony of English is often insufficiently addressed. In fact, the ideological processes by which the fluid and porous nature of English is erased to construct the image of an authoritative “standard” form of English are likely to be an important component of the mechanism by which such hegemony is established. Developing research methods that can be used to observe and question such processes by linking microlevel interactional practices to larger-scale working of ideologies in an empirical way is thus highly desirable.

---

## Future Directions

For the reasons discussed above, it would be important for research on the globalization of English to expand its horizon of inquiry and to seek increasingly interdisciplinary approaches. As we have seen through this chapter, majority of the approaches took language (a category to which English belongs) as a preexisting entity and based their research methods upon that entity, attempting to understand the forms of English, functions of English, and attitudes to English. But as more

recent studies based on the poststructural perspective have shown, questioning the dominant notion of language can in itself provide us with an important way forward in achieving a better understanding of the globalization of English as it relates to the everyday experiences and practices of speakers on the ground. Because of this, there is a great need for interdisciplinary approaches that can move us beyond the traditional scope of linguistics and language study toward interfaces with social dimensions that illuminate the practical conditions of English in the real world.

One example of this might be various approaches that explore the materiality of language (Shankar and Cavanaugh 2012). Problematizing the way language has been conceptualized in abstract terms, various directions of research have begun to consider language as inherently material, grounded in the physical and embodied realities of communicative action. This is particularly a useful perspective for researching the global spread of English, which is necessarily connected with the dimensions of space and mobility invoked by globalization. For instance, Pennycook and Otsuji (2014) attempt to deal with the materiality of communicative practice through their analysis of the way language, activities, and space are intertwined as speakers engaged in specific activities (e.g., working in the tight spaces of a busy restaurant) must find their way across various spaces and simultaneously draw upon multiple linguistic resources. In contrast, Park (2014) considers the larger-scale movement of speakers across different spaces on the transnational level, treating such dimensions of mobility as closely mediated by ideologies of English.

Another example of a potentially fruitful interdisciplinary direction of research is that of language and desire. Inspired by Spivak's (2002) work, Motha and Lin (2014) argue that desire has been undertheorized in research on English language teaching, despite its obvious importance in helping us understand the place of English in the world; desire for power, material benefits, and distinct identities have always shaped the way people relate to and reach out for English. In fact, Motha and Lin argue, large part of the inequalities that are reproduced through the hegemony of English derives from the way desire for English is manipulated and distorted, arguing for more liberatory practices of English language learning that can be used to intervene in the problematic social relations generated by the global spread of English. Focusing on the intersubjective processes through which such desires for English are shaped, circulated, and negotiated can thus provide a powerful methodological basis for addressing the issues of power in the globalization of English.

While such interdisciplinary approaches seem to displace English from being the privileged center of analytic focus, the kind of shift in perspective they offer is indeed indispensable for methodological innovations that can open the door to a more holistic understanding of the complex phenomenon of globalization of English.

---

## Cross-References

- ▶ [Ethnography of Language Policy](#)
- ▶ [From Researching Translanguaging to Translanguaging Research](#)

- ▶ [Investigating Language Education Policy](#)
- ▶ [Sociology of Language and Education: Empirical and Global Perspectives](#)
- ▶ [Theoretical and Historical Perspectives on Researching the Sociology of Language and Education](#)

---

## Related Articles in the Encyclopedia of Language and Education

- Christina Higgins: [Language Education and Globalization](#). In Volume: Language Policy and Political Issues in Education
- Sally Magnan: [Foreign Language Education in the Context of Institutional Globalization](#). In Volume: Second and Foreign Language Education

---

## References

- Berns, M. (2012). Research methods and world Englishes. In C. A. Chapelle (Ed.), *The encyclopedia of applied linguistics*. Oxford: Blackwell.
- Bhatia, T. K. (1987). English in advertising: Multiple mixing and media. *World Englishes*, 6(1), 33–48.
- Block, D., Gray, J., & Holborow, M. (2012). *Neoliberalism and applied linguistics*. London: Routledge.
- Bolton, K. (2005). Where WE stands: Approaches, issues, and debate in world Englishes. *World Englishes*, 24(1), 69–83.
- Bolton, K. (2012). World Englishes and linguistic landscapes. *World Englishes*, 31(1), 30–33.
- Canagarajah, S. (2013). *Translingual practice: Global Englishes and cosmopolitan relations*. New York: Routledge.
- Fishman, J. A., Cooper, R. L., & Conrad, A. W. (Eds.). (1977). *The spread of English: The sociology of English as an additional language*. Rowley: Newbury House.
- Garcia, O. (2009). *Bilingual education in the 21st century: A global perspective*. Oxford: Blackwell.
- Graddol, D. (1997). *The future of English?* London: British Council.
- Graddol, D. (2006). *English next*. London: British Council.
- Greenbaum, S. (1996). *Comparing English worldwide: The international corpus of English*. Oxford: Oxford University Press.
- Henry, E. S. (2010). Interpretations of “Chinglish”: Native speakers, language learners and the enregisterment of a stigmatized code. *Language in Society*, 39(05), 669–688.
- Ho, M. L., & Platt, J. T. (1993). *Dynamics of a contact continuum: Singaporean English*. Oxford: Oxford University Press.
- Kachru, B. B. (Ed.). (1982). *The other tongue: English across cultures*. Oxford: Pergamon.
- Kachru, B. B. (1983). *The Indianisation of English: The English language in India*. New Delhi: Oxford University Press.
- Kachru, B. B. (1985). Standards, codification and sociolinguistic realism: The English language in the outer circle. In R. Quirk & H. G. Widdowson (Eds.), *English in the world: Teaching and learning the language and literature* (pp. 11–30). Cambridge: Cambridge University Press.
- Kortmann, B., & Schneider, E. W. (Eds.). (2004). *A handbook of varieties of English*. Berlin: Mouton de Gruyter.
- Leimgruber, J. (2012). Singapore English: An indexical approach. *World Englishes*, 31(1), 1–14.
- Martin, E. (2002). Mixing English in French advertising. *World Englishes*, 21(3), 375–401.

- May, S. (2014). Contesting public monolingualism and diglossia: Rethinking political theory and language policy for a multilingual world. *Language Policy*, 13(4), 371–393.
- Motha, S., & Lin, A. (2014). “Non-coercive rearrangements”: Theorizing desire in TESOL. *TESOL Quarterly*, 48(2), 331–359.
- Park, J. S. (2009). *The local construction of a global language: Ideologies of English in South Korea*. Berlin: Mouton de Gruyter.
- Park, J. S. (2014). Cartographies of language: Making sense of mobility among Korean transmigrants in Singapore. *Language & Communication*, 39, 83–91.
- Park, J. S., & Wee, L. (2012). *Markets of English: Linguistic capital and language policy in a globalizing world*. New York: Routledge.
- Pavlenko, A. (2005). *Emotions and multilingualism*. Cambridge: Cambridge University Press.
- Pennycook, A. (1998). *English and the discourses of colonialism*. London: Routledge.
- Pennycook, A. (2001). *Critical applied linguistics: A critical introduction*. Mahwah: Lawrence Erlbaum.
- Pennycook, A. (2007). *Global Englishes and transcultural flows*. London: Routledge.
- Pennycook, A., & Otsuji, E. (2014). Metrolingual multitasking and spatial repertoires: “Pizza mo two minutes coming”. *Journal of Sociolinguistics*, 18(2), 161–184.
- Phillipson, R. (1992). *Linguistic imperialism*. Oxford: Oxford University Press.
- Piller, I. (2001). Identity constructions in multilingual advertising. *Language in Society*, 30(2), 153–186.
- Platt, J., Weber, H., & Ho, M. L. (1984). *The new Englishes*. London: Routledge & Kegan Paul.
- Quirk, R. (1962). *The use of English*. London: Longman.
- Rowland, L. (2016). English in the Japanese linguistic landscape: A motive analysis. *Journal of Multilingual and Multicultural Development*, 37(1), 40–55.
- Schneider, E. W. (2003). The dynamics of new Englishes: From identity construction to dialect birth. *Language*, 79(2), 233–281.
- Schneider, E. W. (2007). *Postcolonial English: Varieties around the world*. Cambridge: Cambridge University Press.
- Seidlhofer, B. (2010). Giving VOICE to English as a lingua franca. In R. Facchinetti, D. Crystal, & B. Seidlhofer (Eds.), *From international to local English – And back again* (pp. 147–163). Bern: Peter Lang.
- Shankar, S., & Cavanaugh, J. R. (2012). Language and materiality in global capitalism. *Annual Review of Anthropology*, 41(1), 355–369.
- Spivak, G. (2002). *Postcolonial literature*. Paper presented at the Graduate Seminar on Postcolonial Literature, University of Hong Kong, Hong Kong.
- Tollefson, J. (1991). *Planning language, planning inequality: Language policy in the community*. London: Longman.
- Trudgill, P., & Hannah, J. (1982). *International English: A guide to varieties of standard English*. London: Arnold.

---

# Investigating Language Education Policy

Bernard Spolsky

---

## Abstract

Drawing its examples from published research and from the author's own experience, the chapter presents various stages of a research project in language education policy: establishing the current policy, asking why this policy was selected, investigating the implementation of the policy, and evaluating the policy and suggesting alternatives and improvements. In conclusion, the chapter asks who is most qualified to carry out this kind of research, addresses the problem of finding support for a research project, and considers the prospects for future research in the field.

---

## Keywords

Policy • Management • Navajo • Maori • Arabic • Bilingual • Cost

## Contents

Introduction: Definitions .....	40
Major Contributions and Works in Progress: Four Key Questions .....	40
Research Question: What Is the Policy? .....	40
Research Question: Why This Policy? .....	43
Research Question: How Is the Policy Implemented? .....	44
Research Question: Can the Policy Be Improved? .....	45
Current and Future Questions: Who Should Do Research on Language Education Policy? .....	47
Problems and Difficulties: Support for Research and Its Possible Cost .....	48
Future Directions .....	49

---

B. Spolsky (✉)  
Bar-Ilan University, Ramat Gan, Israel  
e-mail: [bspolsky@gmail.com](mailto:bspolsky@gmail.com)



---

Cross-References .....	50
Related Articles in the Encyclopedia of Language and Education .....	50
References .....	50

---

## Introduction: Definitions

Before we can discuss how to carry out or read<sup>1</sup> research in language education policy, we need to define the field. Language education policy is a significant part of language policy. In the model developed by Kloss (1966) and enriched by Cooper (1989), language policy deals with the status of languages and varieties (are they official or not? what functions are they used for?), their form (are they standardized? are they appropriately cultivated to perform the functions associated with their status?), and who (apart from people who grew up speaking them) else should learn them. Cooper called this last aspect “language acquisition policy” and I call it language education policy (Spolsky 2004). In practice, the three areas are closely intertwined. For instance, in a nation where a language is official (in status), it will generally be used as the medium of instruction in state schools and therefore will need a writing system and terminology for modern concepts and technologies, and it will have to be taught to the children of minority groups and immigrants.

Language policy is usefully seen as having three main components: the practices of the members of the speech community (who actually uses what variety and for what purpose?), their beliefs (what do they think they should do?), and management, which is when someone with or claiming authority tries to modify the practices of someone else (Spolsky 2004). From this, it follows that language *education* is a kind of language *management*. Management is modifying the language practice of someone by adding a language or changing the variety they use. However, it is still relevant to identify the actual practices. For example, teachers in Arabic-speaking countries say they want their pupils to learn Classical or Modern Standard Arabic, but most commonly they conduct their classes in the local vernacular (Amara and Mar’i 2002); and certainly many teachers claiming to teach in English are actually speaking the local language while using English textbooks.

---

## Major Contributions and Works in Progress: Four Key Questions

### Research Question: What Is the Policy?

In research, the appropriate method depends on the question being asked. In studying language education policy, there are two regular research questions. The first is what is the policy of a particular social group or institution or region or

---

<sup>1</sup>Among books on research methods in applied linguistics, Seliger and Shohamy (1989) set out to teach students how to do research; Perry (2005) assumes a more manageable task is to train them how to read research.

nation? Elana Shohamy and I investigated this in Israel (Spolsky and Shohamy 1999). I have also tried to do this for the USA (Spolsky 2006). North (2008) studying in particular the Common European Framework of Reference for Languages, asks whether a policy is to apply locally or over a wider region. Hornberger and Hult (2008) ask about the effect of ecological models on language education policy in Sweden and the Andes. The second is what is the effect of any particular policy? There have been a whole slew of studies of the effects of various kinds of bilingual and immersion education policies (Baker 2011). There are many studies like Cha and Ham (2008) looking at the impact of English on school language programs. A third question can be derived from these two: what is the most desirable policy for any particular group? The first important such case that I was involved in was the Navajo Reading Study, in which we were encouraged to investigate the effect of teaching young Navajo children to read in their own language first (Spolsky 1974, 1975). I will derive a number of my examples from this and other personal experiences. There are many studies looking at individual cases: Orman (2008), for instance, looks at the effect of recent South African language policy on identity building.

None of these three questions is easy to answer, although as is common in difficult public policy issues, there are many people who hold strong opinions about the correct answer. For example, UNESCO experts believed (UNESCO 1953) and still regularly proclaim that children find it easier to learn to read a language or variety of language that they speak. Most school systems however assume that their first responsibility is to teach children how to read the official national language. Walter (2003) estimates that “Ninety-one countries have populations in which 40 percent or more of the national population consists of ethnic and linguistic minorities most of whom receive their schooling (if any) in a language other than their first language” (p. 621).

If we wish to investigate the language education policy of a defined social unit (usually a nation, but one can ask the same question fruitfully of a region or a city or a church or even of a family), the easiest place to start is to look for explicit official documents. But one of the traps we fall into with the word *policy* is that there is no obvious verb form. I prefer “management” because there is clearly an underlying sentence, “someone manages something.” This should immediately set us to ask, who is the manager? Was it the constituent assembly, and if so, how was it elected? Language policy is one of the questions that faced the constituent assemblies in Afghanistan and Iraq. Is it the prime minister or the government? In Malaysia, recently, the prime minister surprised many people by proclaiming a change in medium of instruction at all levels, from Bahasa Melayu to English; the decision was later reversed. The Philippines parliament debated a similar change from bilingual Pilipino and English to English only. In Japan, in 2006, a new minister of education called for teaching Japanese well before starting to teach English. For language education policy, is it the Ministry of Education, the minister, the curriculum director, the school principal, or the teacher? And what roles might local municipalities have in setting policy (Siiner 2014)? Without answers to these questions, we cannot know the standing of any policy document. Some scholars, following Phillipson (1992), suggest that all language policy is driven by powerful

government institutions, but more generally it turns out to be the result of complex dynamic interactions among a wide number of stakeholders at different levels. Identifying the nature of these interactions is a critical goal for research.

For a modern nation-state, overall language policy is commonly set out in a constitutional clause, in countries with a constitution (for a collection of national constitutions, see Jones 2001), or in a law dealing specifically with language. In some cases, constitutions or laws will specify which languages are to be media of instruction or which languages are to be taught or otherwise encouraged. But it needs a lawyer to do the initial research on what the law is: see, for instance, the detailed study of US law (Del Valle 2003), of Israeli law (Deutch 2005; Saban and Amara 2002), of Welsh laws (Huws 2006), and of the early stages of the Maori Language Act (Benton 1979). The Israeli situation, in spite of a modification of a British Mandatory regulation by the newly established independent Israeli government, is not straightforward. The British policy set English, Arabic, and Hebrew as official languages, confirming a policy established by the British Army when it occupied Ottoman Palestine in 1919. But the meaning of the designation was not clear: the regulations refer to posting of official notices. As the British left education to the communities, Arab schools used Arabic and Jewish schools taught either in Hebrew or Yiddish. After the country was divided, Jordan passed a law requiring all schools, including mission schools that had preferred international languages, to teach in Arabic. In Israel, the committee preparing educational policy for statehood debated language for over a year, deciding a few days before independence to follow a Treaty of Versailles principle of adopting the language of the majority of parents, thus establishing Arabic as first language in Arab schools and Hebrew in Jewish schools. Once a written policy has been found and interpreted (e.g., deciding the meaning of such disputed terms as “official” and “national” and “minority”), one next needs to look for evidence, for instance, in published regulations, or in institutional arrangements, or in budgetary allocations, that the stated policy is in fact being implemented.

In the case of language education policy, it often turns out to be quite difficult to find clear evidence. Even when there is a written policy, such as the Dutch National Programme (van Els 1992), the definition of terms and the meaning attached to language names can be problematic. For example, most Arabic-speaking states have a constitutional clause stating that their religion is Islam and their language is Arabic. While this generally can be assumed to include the goal of teaching both Qur’anic Arabic and Modern Standard Arabic, it gives no indication of the language variety used by pupils and teachers in the classroom, which is usually a regional variety like Egyptian or Palestinian or Iraqi Arabic. Many countries with complex multilingual ecologies do not make clear which variety of language is normally chosen as medium of instruction at various educational levels and how that relates to the home language of the students. As an example, home language is often referred to as the “mother tongue,” but that term is also rarely defined; what about children brought up in the increasing number of bilingual homes in multilingual cities? Generally, though, a good place to look for evidence of the languages used or taught in school is in a curriculum: if there is no other specification, it can be assumed that the unmarked medium of instruction is a standard variety of the national or official

language and that any other language taught will be listed specifically. In New Zealand, education was bilingual in Māori and English until 1860, when Māori was dropped as a language of instruction; in the 1920s, it was allowed as a high school examination subject. It became the language of instruction again in the immersion programs that Māori activists established starting in 1980.

Language education policy is sometimes found in the reports of conferences or committees or occasionally *ex cathedra* pronouncements by prime ministers. Phillipson (1992) describes the various conferences at which proposals for language education policy in Africa were debated. The decision that Jewish and Arab schools should teach in Hebrew and Arabic, respectively, was made by a committee. The Thelot committee in France shocked many by proposing that the status of English in schools should be raised (Thelot 2004).

Ideally, investigators try to find an explicit statement of language of instruction for the various levels of educational system and details of the use and teaching of other languages. They will also look for evidence of implementation in teacher selection and training, years and hours of instruction, provision of textbooks and other resources, inclusion of language proficiency in examinations, and any other evidence of evaluation. All of this produces what we might loosely call the management plan, and the research approach followed is similar to the study of other aspects of educational policy.

## **Research Question: Why This Policy?**

There are two directions a researcher might next want to follow: to investigate the reasons for a policy or to see how it is implemented. Language education policy, like language policy in general, derives essentially from an understanding (often weak and imprecise and rarely accurate) of the current language practices and proficiencies of a society and from a set of beliefs (or ideology) of what should be an ideal situation (Spolsky 2004). Often, the development of a workable policy is blocked by a strong belief in ideal monolingualism, as Scarino (2014) has shown in Australia. This was the case in New Zealand in the 1860s and hinders the recognition of other languages in many countries. Language managers sometimes make their motivations explicit. They will commonly describe pragmatic goals, such as improving the economic prospects of the country (for instance, in Singapore), integrating new immigrants (e.g., in the USA and Israel), or building a more skillful or educated citizenry, or they will set symbolic goals such as unifying the nation (in Islamic countries and in Indonesia, preserving heritage values, providing access to the true faith in Islamic countries) and building democracy. The investigator's goal could be to discover which of these motivations are relevant or, in their absence, to analyze the policy and determine who benefits from it.

In order to do this, the scholar studying language education policy will often find it necessary to move outside the educational realm to discover (in published material or through direct investigation) the current sociolinguistic ecology of the relevant speech community: what languages or varieties of language are used by what members or sections of the community and for what functions.

In the Navajo Reading Study, our first task was a sociolinguistic study to see whether the Navajo language was still widely spoken. We found that 90% of the children coming to Bureau of Indian Affairs schools in 1969 encountered English for the first time upon arrival (Spolsky 1970). Some of these materials may be available in national censuses, but census results need careful use (de Vries 1990; Thompson 1974). Other information may have been published in sociolinguistic surveys, such as the Ford Foundation language surveys of East Africa (Bender et al. 1976; Ladefoged et al. 1972).<sup>2</sup> Not uncommonly, the investigator will need to conduct an original sociolinguistic survey, such as our study of the situation of Navajo in 1969 (Spolsky 1970), or the survey of the health of the Maori language (Statistics New Zealand 2001). Our study of Israeli language policy involved looking at the status of each language spoken (Spolsky and Shohamy 1999). In planning its complex language management activities (usually combining the development of literacy and the translation of the Christian Bible), SIL International originally focused on detailed studies of language structure, but more recently has recognized the need for good sociolinguistic surveys, looking at the intelligibility of dialects and degree of bilingualism.

Such a survey might also usefully include a study of the beliefs and attitudes of the community and its various sectors. Do they believe that monolingualism is natural and normal? Do they think a multilingual society is possible or desirable? What values do they attach to plurilingual proficiency? How do they value each of the languages that might be included in the policy? It is common to believe that a national language serves to unite a nation and should be given the highest value, but there are also pragmatic reasons (e.g., economic values) attached to international languages like English. This explains Singapore language policy and the attempt in Malaysia to teach math and science in English. It is also common for minority languages and dialects to be stigmatized. Political considerations can also be important, as when many East European countries switched from Russian (imposed in the Soviet period) to English as a first foreign language. Questions like these need to be asked separately of the managers, of the teachers, and of the students in the education system and of parents and other community members. At this point, one can usefully look for conflicts in values and attitudes: does the school have the same goals as the national government on the one hand and as its pupils on the other? Are there significant sections of the community with different opinions?

### **Research Question: How Is the Policy Implemented?**

Once the management plan is known and the beliefs or ideologies that underlie it, the next obvious task is to find out what happens in practice. One useful starting point is the linguistic proficiency of the teachers in the system. If the policy calls for a

---

<sup>2</sup>SIL International has started to conduct and publish electronically detailed sociolinguistic studies; see <http://www.sil.org/silesr/>. These give clear and useful methodological information.

specific language of instruction to be used, are there in fact enough teachers to do this? It took nearly a century after France determined that French should be the language of instruction in all its schools before there were enough teachers qualified for this. After a while, the Navajo Reading Study moved its emphasis to teacher training. When I revisited New Zealand, Maori educators expressed regret that my recommendation to the Department of Education to put emphasis on teacher training (Spolsky 1987) was never taken seriously enough. Another is the availability of resources: if a certain language is chosen, is written material available for school use in the language? One of our first products in the Navajo Reading Study was a list of materials in the language (Holm et al. 1970). Are there developed curricula that coincide with the language aims of the policy? When Māori language started to be used in New Zealand in the 1970s and 1980s, there were few if any qualified teachers who were also fluent in the language. But when a program for Pacific languages was considered in New Zealand, it turned out that there were many trained fluent Samoan and Tongan teachers available, if only the policy had been adopted.

The approach so far has been descriptive rather than evaluative, although it is clear that a careful description will reveal major discrepancies between various parts of the policy and between the policy and its implementation. Examples are unfortunately very easy to come by: when I first visited Navajo schools in the late 1970s, I found that all the teaching was being done by monolingual English-speaking teachers using normal curricula for English-speaking US students while most of the pupils were Navajo speakers with very limited English ability. When I visited Thailand a little later, English was included in the elementary school curriculum although most teachers at that level had only a rudimentary knowledge of it. It is still the case in many schools throughout the world that the system does not take into account the fact that pupils come to school speaking a variety of languages that is not the goal of the system. Nero (2014) shows the effect of this confusion in Jamaican schools. A complete description then will already reveal the problems in a language education policy. Other gaps and inconsistencies will emerge from comparing the goals of instruction of various sectors of the community (e.g., the Bahasa Melayu policy in Malaysian education and government and the English policy in the business world) or from comparing the language skills output by the system with the skills that appear to be needed in the workplace.

### **Research Question: Can the Policy Be Improved?**

This brings us to studies that wish to move beyond description to prediction; for instance, what change in policy will lead to a change in output? Or to evaluation? In other words, is this the best policy in the given situation, or to knowledge-based prescription, what changes in the policy are desirable? Here again, we seem to have plenty of opinions and comparatively little hard evidence.

There is a school of educational research that likes the agricultural model: in agriculture, one can compare the yield of a field given regular water and fertilizer with one left alone. In education, including language education, the number of

potential factors and the ethical implications of controlled experiments mean that this model is not usable. There are others that prefer the clinical model of matched populations and the double blind use of placebos (e.g., *Please forgive us if we give you a sugar pill rather than using one we believe will cure you*). This too produces practical and ethical problems. Rather, a long and expensive process of making minor approved changes and observing the effects of a whole range of results which are difficult to measure seems to be called for. In the Navajo case, it took 10 years to produce a longitudinal study of the effects of starting instruction in Navajo in the first grade (Rosier and Holm 1980), but the authors drew attention to all the other changes that had taken place in the meantime. In the 1970s, a committee recommended the US Office of Education to start collecting baseline data to observe the effects of proposed bilingual programs. This was never implemented. However, political and other pressures on an educational system appear to militate against the possibility of this strategy too. This point is illustrated by the reluctance of the US Department of Education to permit publication of a study it funded to review the research literature on the development of literacy among language minority children and youth because its results did not support current policy.<sup>3</sup>

Lacking usually the resources to conduct the necessary long-term research with careful collection of a wide range of potentially relevant data, one research strategy is to undertake historical or comparative studies. When arguments are presented for the need to teach speaking a language before reading it, how do we account for the seemingly successful maintenance over centuries of knowledge of classical and sacred languages like Latin and Hebrew that were not spoken? A recent book by Botticini and Eckstein (2012) looks at the effect of the development of schools teaching Hebrew literacy after the destruction of the temple by the Romans. The facts they set out to explain were the drop in Jewish population from about six million at the time of Jesus to about one million in the ninth century CE, showing that only a proportion of the Jewish community (mainly working at the time in agriculture) could afford to send their sons to school. But by the tenth century, Jews who had been educated were able to move to skilled trades and commerce, serving either a Christian or Muslim population that had not yet developed popular education.

Some earlier studies that attempted to evaluate language education policy are worth noting. Scherer and Wertheimer (1964) made a valiant but failed effort to study the value of the audio-lingual method (ALM). First-year German classes at the University of Wisconsin were divided into two groups: one set to receive “traditional” teaching and the second to be given ALM teaching, the “treatment” condition. The results of the first year suggested that the traditional group did a little better in reading and grammar and the ALM group did a little better in speaking. The experiment did not continue into its planned second year, as students declined to be assigned to the no-treatment condition.

---

<sup>3</sup>See <http://www.nabe.org/press/press9.html>. An article by Michael Grunwald in October 1, 2006, in the *Washington Post* describes a report by the Inspector General of the Department of Education on similar problems with Reading First.

Much more successful in its effect on language education policy was the study by Lambert and Tucker (1972) of the St. Lambert experiment in bilingual education. Reacting to their sense of the growing language consciousness of the francophone majority in Quebec, a group of middle-class anglophone parents in one Montreal suburb persuaded the Protestant School Board, against its better judgment, to permit them to try early French immersion instruction for their English-speaking children. Lambert and Tucker agreed to provide the evaluation, which produced two important conclusions – children in the program learned more French than in traditional French classes, and once they had moved to a balanced English and French instructional program, they reached the expected standards in the subjects taught and tested in English. It was only some time later that further studies (Swain and Lapkin 1982) showed that their French remained less than native. The success of the program and of similar Canadian bilingual programs for English speakers provided support for continued expansion of a politically supported effort to produce Canadian Anglophones with proficiency in French.

Two similar studies with minority groups had less effect, though their results were similar. An important study by Modiano (1973) in the Chiapas Highlands produced evidence that Indian children taught to read first in their own language were later more successful than others in learning to read Spanish. A study inspired by the Chiapas study which was conducted among Navajo Indians (Spolsky 1974) was ultimately tested in a longitudinal study in one school; Rosier and Holm (1980) showed that Navajo children taught reading first in their own language ultimately reached much better than normal results in regular English tests. Other examples include a recent report by Little and McCarty (2006), which finds encouragement in recent studies of bilingual and immersion programs in some Native American communities; also, studies like King and Benson (2003) and Hornberger and King (2001) describe the effects of language revitalization projects in South America. Reyes and Crawford (2011) describe the approach and outcomes of a successful dual immersion program in the USA. For a variety of reasons (Spolsky 2002), these and many other studies that show the effectiveness of well-designed and monitored bilingual programs (Walter 2003) form a part of the “*connaissance inutile*” (Revel 1988) that fails to inform language education policy in the USA and elsewhere.

### **Current and Future Questions: Who Should Do Research on Language Education Policy?**

I turn to a related and increasingly pervasive question, that of who should investigate language education policy. Apart from the obvious academic qualifications (adequate skills according to the research method in the languages involved, statistics, testing, history, discourse analysis, ethnographic observation, questionnaire writing, and interpreting, interviewing, for instance), one important question is the researcher’s own identity as an outsider or as a member of the group being studied. By definition, an academic researcher is an outsider, trained to look as dispassionately as possible at the people and phenomena he or she is studying. But, scholars



like Joshua Fishman have taught us how rigorous scientific methods can be combined with deep empathy for the group being studied. At the same time, in language education studies as in other sociolinguistic work, it is valuable to involve in the research members of the community being studied. In my work with Navajo, I depended largely on Navajo associates and colleagues and learned from them constantly. In our study of the Old City (Spolsky and Cooper 1991), while we used research assistants with knowledge of local languages, the absence of a senior Arabic-speaking colleague probably biased our presentation; this was corrected in subsequent studies of an Israeli Palestinian village (Amara and Spolsky 1996; Spolsky and Amara 1997) and of a West Bank Arab town (Spolsky et al. 2000). More and more, the local informant is being transformed into the research associate or director. Hornberger (2014) gives details of three language activists who are making major contributions to language education in their communities.

---

### **Problems and Difficulties: Support for Research and Its Possible Cost**

Moving closer to the nitty-gritty, we turn to the selection of a topic and the often related question of finding support for research in language education policy. Here, there is an obvious distinction between independent and dependent researchers. By independent researcher, I mean someone who can carry out the research without additional resources or funding. One such case may be a classroom teacher who decides to conduct a study in his or her classroom, requiring only the appropriate permissions from institutional authorities including committees on the rights of human subjects. I remember my son's fourth grade teacher who made a detailed study of what happened in his highly innovative classroom; the principal told me that the teacher spent several hours every night after school analyzing the extensive notes he took on each pupil's behavior during the day and weekends writing up his results into a thesis that ultimately earned him a doctorate (and lost him a wife). Because the research was part of a degree program, it was of course partly shaped by his dissertation advisers, but all the resources of time were his own. Similarly, the choice of topic was influenced by his professors, but his research design and methods were simply an intelligent exploitation of readily available data. When research depends on published or archival material, and increasingly nowadays when such material is readily available on the web, the main concern of the researcher is to find time.

Research time is sometimes provided by a sabbatical or other leave or by a grant or fellowship. In these cases, the research project will need review and approval by some committee or foundation. When the research involves not just one scholar collecting data (or two or more collaborating), the need to obtain funding to pay for assistance, equipment, statistical advice, payments to subjects, travel, and other costs usually involves the prospective researcher in applying to a government or private agency for the funds, a process which inevitably means that the project must conform to some degree in the agency's program of research. When I was starting out, I recall an aphorism that I continue to quote: theoretical research is what you

want to do and applied research is what they will give you money to do. The happy researcher is of course the one who gets money to do what he or she wants to do. When we started the Navajo Reading Study on the initiative of a senior educator in the Bureau of Indian Affairs who wanted us to repeat the Chiapas (Modiano 1973) study with Navajos, we were exceptionally fortunate that he set no timetable and allowed us to proceed with the task in what seemed to us the most logical way. In practice, the initial grant only allowed for a number of preliminary projects, including the language survey which depended on access to the schools which we obtained through our semiofficial status. From then on, each stage of the study depended on obtaining new funding, usually from the US Office of Education under the bilingual education program. One unfortunate result of the limitation to 1-year grants was a damaging annual tempo: shortly after receiving a new grant (and commonly it did not arrive at the beginning of the school year), we had to start work immediately on a final report and new grant application. This left our research staff without financial support at the beginning of the school year. One year, my research assistant came back late in the summer with a check he had received from a stranger he talked to in a restaurant; we were thus able to keep paying the Navajo students who played a significant role in our work. Fortunately, we were subsequently able to persuade the Ford Foundation of the value of the project, and their grant came without the time constraints of the US government. When we started on the study of Israeli education, we offered at the end of 2 or 3 years of research to propose a new language education policy. However, the minister of education could not wait; he asked for a draft which he could adopt before we started work. As a result, the policy was never accepted by the Ministry once a new minister succeeded. In New Zealand, a major proposal for a language education policy similarly ended in a drawer, suffering the fate of most advice from outside experts and consultants. It is clearly important to make sure a proposal has strong support from those who will need to implement it.

In obtaining outside support, we regularly had to tailor our goals and methods to the programs that were supporting us. The potential ethical quandary is one that all researchers face when they seek outside support. In essence, the researcher must constantly balance his or her own research goals with those of the supporting institutions. For this reason, it is most useful to have a research program that can be adapted to changing circumstances and resources.

---

## Future Directions

Research in language education policy covers a wide range of significant topics and so requires, as I have tried to suggest, an equally wide range of methods, all of which are described in detail in this volume. With the growing recognition of the importance of the area, there is an expanding choice of academic journals in which to publish results and of publishers who will consider monographs on the topic. This provides a good test of the value of the research, as its publication permits other scholars to question it or to build on it.

With this increasing interest in the field, no doubt a great deal of research will continue to earn degrees or promotion rather than to add knowledge, but there are signs that many scholars are now backing their beliefs with reasonably solid data rather than rhetoric. A study like King (2000) that bases hypotheses about language revitalization on a long-term ethnographic study or like Walter (2003), which discusses the choice of medium of education on the basis of rigorous analysis of statistical data rather than by appeals to rights, are examples of the best methods.

---

## Cross-References

- ▶ [Critical Ethnography](#)
- ▶ [Ethnography and Language Education](#)
- ▶ [Ethnography of Language Policy](#)
- ▶ [Language Teacher Research Methods](#)
- ▶ [Theoretical and Historical Perspectives on Researching the Sociology of Language and Education](#)

---

## Related Articles in the Encyclopedia of Language and Education

- James Tollefson: [Language Planning in Education](#). In Volume: Language Policy and Political Issues in Education
- Teresa McCarty and Serafin Coronel-Molina: [Language Education Planning and Policies by and for Indigenous Peoples](#). In Volume: Language Policy and Political Issues in Education

---

## References

- Amara, M. H., & Mar'i, A. A. (2002). *Language education policy: The Arab minority in Israel*. Dordrecht: Kluwer.
- Amara, M. H., & Spolsky, B. (1996). The construction of identity in a divided Palestinian village: Sociolinguistic evidence. In Y. Suleiman (Ed.), *Language and identity in the Middle East and North Africa* (pp. 81–100). Richmond: Curzon.
- Baker, C. (2011). *Foundations of bilingual education and bilingualism* (5th ed.). Clevedon: Multilingual Matters.
- Bender, M. L., Bowen, J. D., Cooper, R. L., & Ferguson, C. A. (Eds.). (1976). *Language in Ethiopia*. London: Oxford University Press.
- Benton, R. A. (1979). *The legal status of the Maori language: Current reality and future prospects*. Wellington: Maori Unit, New Zealand Council for Educational Research.
- Botticini, M., & Eckstein, Z. (2012). *The chosen few: How education shaped Jewish history* (pp. 70–1492). Princeton: Princeton University Press.
- Cha, Y.-K., & Ham, S.-H. (2008). Ecological language education policy. In B. Spolsky & F. M. Hult (Eds.), *The impact of English on the school curriculum* (pp. 313–327). Oxford: Blackwell.
- Cooper, R. L. (1989). *Language planning and social change*. Cambridge: Cambridge University Press.

- de Vries, J. (1990). On coming to our census: A layman's guide to demolinguistics. *Journal of Multilingual and Multicultural Development*, 11(1&2), 57–76.
- Del Valle, S. (2003). *Language rights and the law in the United States: Finding our voices*. Clevedon: Multilingual Matters Ltd.
- Deutch, Y. (2005). Language law in Israel. *Language Policy*, 4(3), 261–285.
- Holm, A., Murphy, P., & Spolsky, B. (1970). *Analytical bibliography of Navajo reading materials*. Washington, DC: Bureau of Indian Affairs, United States.
- Hornberger, N. H. (2014). Portraits of language activists in indigenous language revitalization. In B. Spolsky, O. Inbar-Lourie, & M. Tannenbaum (Eds.), *Challenges for language education and policy: Making space for people* (pp. 123–133). New York: Routledge.
- Hornberger, N. H., & Hult, F. M. (2008). Ecological language education policy. In B. Spolsky & F. M. Hult (Eds.), *Handbook of educational linguistics* (pp. 280–297). Oxford: Blackwell.
- Hornberger, N. H., & King, K. A. (2001). Reversing language shift in South America. In J. A. Fishman (Ed.), *Can threatened languages be saved?* (pp. 166–194). Clevedon: Multilingual Matters Ltd.
- Huws, C. F. (2006). The Welsh language act 1993: A measure of success? *Language Policy*, 5(2), 141–160.
- Jones, J. P. (2001). *Constitution finder*. <http://confinder.richmond.edu/>. Accessed June 2015.
- King, K. A. (2000). *Language revitalization process and prospects: Quichua in the Ecuadorian Andes*. Clevedon: Multilingual Matters Ltd.
- King, K. A., & Benson, C. (2003). Indigenous language education in Bolivia and Ecuador: Contexts, changes, and challenges. In J. W. Tollefson & A. B. M. Tsui (Eds.), *Medium of construction policies: Which agenda? Whose agenda?* (pp. 241–261). Mahwah: Lawrence Erlbaum Associates.
- Kloss, H. (1966). German-American language maintenance efforts. In J. Fishman (Ed.), *Language loyalty in the United States* (pp. 206–252). Hague: Mouton.
- Ladefoged, P., Glick, R., & Cripser, C. (1972). *Language in Uganda*. London: Oxford University Press.
- Lambert, W. E., & Tucker, G. R. (1972). *Bilingual education of children: The St. Lambert experiment*. Rowley: Newbury House Publishers.
- Little, M. E. R., & McCarty, T. L. (2006). *Language planning challenges and prospects in native American communities and schools*. Tempe: Educational Policy Studies Laboratory.
- Modiano, N. (1973). *Indian education in the Chiapas Highlands*. New York: Holt Rinehart and Winston.
- Nero, S. J. (2014). De facto language education policy through teachers' attitudes and practices: A critical ethnographic study in three Jamaican schools. *Language Policy*, 13, 221–242.
- North, B. (2008). Level and goals: Central framework and local strategies. In B. Spolsky & F. M. Hult (Eds.), *Handbook of educational linguistics* (p. 220). Oxford: Blackwell.
- Orman, J. (2008). *Language policy and nation-building in post-apartheid South Africa*. Berlin: Springer.
- Pery, F. L. (2005). *Research in applied linguistics: Becoming a discerning consumer*. Mahwah: Lawrence Erlbaum.
- Phillipson, R. (1992). *Linguistic imperialism*. Oxford: Oxford University Press.
- Revel, J.-F. (1988). *La connaissance inutile*. Paris: Grasset.
- Reyes, S. A., & Crawford, J. (2011). *Diary of a bilingual school*. Portland: Diversity Learning K-12 LLC.
- Rosier, P., & Holm, W. (1980). *The rock point experience: A longitudinal study of a Navajo school program*. Washington, DC: Center for Applied Linguistics.
- Saban, I., & Amara, M. (2002). The status of Arabic in Israel: Reflections on the power of law to produce social change. *Israel Law Review*, 36(2), 5–39.
- Scarino, A. (2014). Situating the challenges in current languages education policy in Australia—unlearning monolingualism. *International Journal of Multilingualism*, 11(3), 289–306.
- Scherer, G. A. C., & Wertheimer, M. (1964). *Psycholinguistic experiment in foreign-language teaching*. New York: McGraw-Hill.

- Seliger, H. W., & Shohamy, E. (1989). *Second language research methods*. Oxford: Oxford University Press.
- Siiner, M. (2014). Decentralisation and language policy: Local municipalities' role in language education policies. Insights from Denmark and Estonia. *Journal of Multilingual and Multicultural Development*, 35(6), 603–617.
- Spolsky, B. (1970). Navajo language maintenance: Six-year-olds in 1969. *Language Sciences*, 13, 19–24.
- Spolsky, B. (1974). The Navajo reading study: An illustration of the scope and nature of educational linguistics. In J. Quistgaard, H. Schwarz, & H. Spong-Hanssen (Eds.), *Applied linguistics: Problems and solutions: Proceedings of the third congress on applied linguistics* (Vol. 3, pp. 553–565). Copenhagen: Julius Gros Verlag. 1972.
- Spolsky, B. (1975). Linguistics in practice: The Navajo reading study. *Theory Into Practice*, 15, 347–352.
- Spolsky, B. (1987). *Maori-English bilingual education (research report)*. Wellington: New Zealand Department of Education.
- Spolsky, B. (2002). Prospects for the survival of the Navajo language: A reconsideration. *Anthropology & Education Quarterly*, 33(2), 1–24.
- Spolsky, B. (2004). *Language policy*. Cambridge: Cambridge University Press.
- Spolsky, B. (2006). Does the US need a language policy, or is English enough? Language policies in the US and beyond. In A. Heining-Boynton (Ed.), *2005–2015: Realizing our vision of languages for all* (pp. 15–38). Upper Saddle River: Pearson Education.
- Spolsky, B., & Amara, M. H. (1997). Politics and language change: The sociolinguistic reflexes of the division of a Palestinian village. In S. Eliasson & E. H. Jahr (Eds.), *Language and its ecology: Essays in memory of Einar Haugen* (pp. 35–74). Berlin: Mouton de Gruyter.
- Spolsky, B., & Cooper, R. L. (1991). *The languages of Jerusalem*. Oxford: Clarendon.
- Spolsky, B., & Shohamy, E. (1999). *The languages of Israel: Policy, ideology and practice*. Clevedon: Multilingual Matters.
- Spolsky, B., Amara, M., Tushyeh, H., & Bot, K. (2000). *Languages in Bethlehem: The sociolinguistic transformation of a Palestinian town*. Amsterdam: Netherlands-Israel Development Research Programme.
- Statistics New Zealand. (2001). *Provisional Report on the 2001 survey on the health of the Maori language*. Wellington: Statistics New Zealand for Te Puni Kokiri.
- Swain, M., & Lapkin, S. (1982). *Evaluating Bilingual education: A Canadian case study*. Clevedon: Multilingual Matters Ltd.
- Thelot, C. (2004). *Pour la réussite de tous les élèves (Rapport officiel)*. Paris: Ministère de l'éducation nationale.
- Thompson, R. M. (1974). Mexican American language loyalty and the validity of the 1970 census. *International Journal of the Sociology of Language*, 2, 7–18.
- UNESCO. (1953). *The use of vernacular languages in education: The report of the UNESCO meeting of specialists*. Paris: UNESCO.
- van Els, T. J. M. (1992). *The Dutch national action programme on foreign languages* (English translation). The Hague: Ministry of Education and Science.
- Walter, S. L. (2003). Does language of instruction matter in education? In M. R. Wise, T. N. Headland, & R. M. Brend (Eds.), *Language and life: Essays in memory of Kenneth L. Pike* (pp. 611–635). Dallas: SIL International and the University of Texas at Arlington.

---

# Ethnography of Language Policy

Teresa L. McCarty and Lu Liu

---

## Abstract

This chapter explores the history, development, and role of ethnographic research in understanding de facto and de jure language policies. With its roots in anthropology, ethnography is characterized by the contextualization of cultural and linguistic phenomena and close attention to participants' point of view. This chapter begins by framing ethnographic research in terms of its distinct ontological, epistemological, and methodological assumptions. The chapter then locates ethnographic approaches to language policy in the complementary fields of educational and linguistic anthropology and socio-educational linguistics. This is followed by an examination of key issues and findings emanating from these disciplinary fields and an exploration of core areas of new research, including critical ethnographic, sociocultural approaches to language education planning and policy, and ethnographic studies of educators as de facto language policymakers. Final sections address the implications of this work for pedagogy, policy, and praxis. Returning to Hymes's (1980) call for an ethnographic science that is reflexive, critical, and democratizing, the authors argue for ethnographic research that engages and works to dismantle persistent linguistic inequalities in education.

---

## Keywords

Ethnography • Language policy • Anthropology of policy • Qualitative research

---

This chapter is adapted from McCarty, T. L. (2015). Ethnography in educational linguistics. In M. Bigelow & J. Enns-Kananen (eds.), *The Routledge handbook of educational linguistics* (pp. 23–37). New York, NY: Routledge (used with permission).

T.L. McCarty (✉) • L. Liu (✉)

Graduate School of Education and Information Studies, University of California Los Angeles, Los Angeles, CA, USA

e-mail: [teresa.mccarty@ucla.edu](mailto:teresa.mccarty@ucla.edu); [teresa.mccarty@asu.edu](mailto:teresa.mccarty@asu.edu); [priscillaliu.bj@gmail.com](mailto:priscillaliu.bj@gmail.com)

## Contents

Introduction .....	54
Early Developments .....	55
Major Contributions .....	56
Work in Progress .....	58
Problems and Difficulties .....	62
Future Directions .....	62
Cross-References .....	63
Related Articles in the Encyclopedia of Language and Education .....	63
References .....	64

## Introduction

With its roots in anthropology, ethnography is both a social science and part of the humanities. The premises that inform ethnographic research are based on anthropological ways of knowing and gathering and assessing evidence, described by the educational anthropologist Harry Wolcott (2008) as a “way of seeing” through the lens of human culture and a “way of looking” based on long-term, firsthand fieldwork. As a way of seeing, ethnography finds its orienting purpose in a “concern with cultural interpretation” (Wolcott 2008, p. 72) – the meanings people make of everyday social practice. For ethnographers of language policy, this entails a view of policy as a situated sociocultural process: the practices, ideologies, attitudes, and mechanisms that influence people’s language choices in pervasive everyday ways and that are contextualized in “cultural phenomena socially, historically, and comparatively across time and space” (McCarty 2011, p. 10). Often these processes involve the cultural artifacts typically associated with policy – official declarations, regulations, and laws – but ethnographers are equally concerned with implicit policy processes, the ways in which people accommodate, resist, and construct policy in their daily lives. Ethnographic studies of language policy seek to describe and interpret these complex micro-, meso-, and macro-level processes and the power relations through which they are normalized.

It follows that ethnographies of language policy are holistic, examining the language planning and policy process as part of a complex and contested sociocultural system. Ethnographers are also acutely attuned to participants’ point of view, often called the emic perspective, a reference to an analogy proposed by Pike (1967) which contrasted phonemics – the tacit knowledge of a language’s sound system held by first-language speakers – with phonetics, the study of sound systems. Emic and etic are commonly understood to refer to “insider” and “outsider” knowledge, respectively.

Ethnographic methods include nonparticipant and participant observation; in-depth, formal, and informal interviews; and the collection and analysis of relevant documents and cultural artifacts. These methods may be supplemented with surveys or questionnaires, censuses, social mapping, quantitative measures such as student achievement data, and photographic and video elicitation techniques. Narrative analysis, discourse analysis, and portraiture are also common in ethnographic

research. Regardless of the strategies employed, the goal is to situate language planning and policy within the larger sociocultural contexts of which they are part. Ricento and Hornberger (1996) use an onion metaphor to describe these multilayered contexts and processes. By “slicing the onion ethnographically” (Hornberger and Johnson 2007), researchers can attend to the fine-grained detail of each layer and its position within a systemic whole.

---

## Early Developments

Initiated by the Americanist anthropologist Franz Boas and Bronislaw Malinowski in what is now the EU, late nineteenth- and early twentieth-century ethnographic fieldwork was largely devoted to documenting Indigenous cultural practices in colonial and neocolonial settings and to collecting vocabularies and texts in Native North American languages. Through documentation, grammatical description, and linguistic classification, it was believed that the genetic relations of non-Western peoples could be reconstructed and their cultural traditions, viewed by White anthropologists as on the verge of extinction due to colonization, preserved and retained (Darnell 1998). As Blommaert and Jie (2010) write, “Ever since its beginnings in the works of Malinowski and Boas, [ethnography] was part of a total programme of scientific description and interpretation” that included not only specific methods but also an ontological and epistemic commitment to cultural relativism and a systemic, “part-whole” view of cultures, societies, and languages (p. 5).

These early methodological traditions undergird subsequent work in the linked subdisciplines of educational and linguistic anthropology, both of which converge in the field of language planning and policy. From educational anthropology came a view of education as a cultural process – a perspective apparent as early as 1928, when Boas’s student, Margaret Mead, published *Coming of Age in Samoa* – developed under the aegis of George and Louise Spindler at Stanford University (Spindler 2000). From linguistic anthropology came the ethnography of communication pioneered by John Gumperz and Dell Hymes (1972). Hymes argued that “language must be studied in ‘contexts of situation,’ and must move beyond grammatical and ethnographic description to look for patterns in ‘speech activity’ [with] the speech community . . . taken as a point of departure” (as cited in Duranti 2003, p. 327). Situated within the emerging interdisciplinary field of socio- and educational linguistics, Gumperz and Hymes proposed a “socially realistic linguistics” in which education was “a prime arena for sociolinguistic research” (Hornberger 2003, pp. 245–246).

In contrast to Boas, Gumperz and Hymes suggested that anthropological studies of language should concentrate on “the features of language that needed reference to culture. . .with the help of ethnographic methods” such as participant observation (Duranti 2003, p. 327). For contemporary ethnographers of language policy, then, the objective is to “employ a first-hand, naturalistic, well-contextualized, hypotheses-generating, emic orientation to language practices. . .[and] to capture



first-hand [i.e., through fieldwork] its language patterns and attitudes” (Canagarajah 2006, p. 155). The union of educational and linguistic anthropology is clearly visible in the ethnographic treatments of language in practice that followed: Cazden et al.’s (1972) *Functions of Language in the Classroom*, Green and Wallat’s (1981) *Ethnography and Language in Educational Settings*, Heath’s (1983) *Ways with Words*, and Philips’s (1983) *The Invisible Culture*.

In the USA, a related line of inquiry has centered on bilingual education. Major works include Trueba et al.’s (1981) *Culture and the Bilingual Classroom* and the California State Department of Education’s (1986) *Beyond Language: Social and Cultural Factors in Schooling Language Minority Students*. This work demonstrated the fallacy of measuring the effectiveness of bilingual education by looking narrowly at students’ English-language performance as measured on standardized tests, without taking into consideration the culture of the classroom and community. As Foley (2005) notes, these ethnographic accounts highlighted “cognitive and sociolinguistic notions of culture and...advocate[d] a sociolinguistic version of educational ethnography as innovative and useful” (p. 355). At the same time, in the UK, anthropologists such as Brian Street (1984) began applying ethnography to examine multilingual literacies and literacy policy in cross-cultural and cross-national contexts. Together, these interwoven strands of educational and linguistic anthropology laid down a sociocultural theoretical and methodological foundation for policy-oriented linguistic-educational ethnographic research.

---

## Major Contributions

A major line of inquiry in the ethnography of language policy has addressed the question of how linguistic diversity is constructed as a resource or a problem in schools and society. What is the role of education in structuring social and linguistic hierarchies inside and outside of schools? How do explicit and implicit language education policies reflect and reproduce linguistic hierarchies and relations of power?

Grounded in social constructivism, much of this research has focused on language ideology and identity formation, which connects “larger institutional structures and processes... [with] the ‘textual’ details of everyday encounters (the so-called macro-micro connection)” (Duranti 2003, p. 332). One important stream of this work has investigated the ideological and institutional mechanisms that promote language shift, spread, maintenance, and revitalization. In 1988, Hornberger published a case study of bilingual (Quechua-Spanish) education policy and practice in Puno, Peru. Focusing on the relationship between official policy and local language practices, she explored whether schools can be effective agents for language maintenance. At the center of this ethnographic investigation were local language uses and ideologies that positioned Quechua as the extra-school or home-community language and Spanish as the language of academics and schooling. Pairing these local processes with macro processes at the societal level, Hornberger also pointed to decreasing isolation and the low social status of

Quechua speakers as factors that mitigated against the *ayllu* or family-/community-level language transmission processes. At the same time, problems of local implementation and government instability undermined macro-level policies supporting Quechua-language maintenance. This study was among the first to demonstrate through fine-grained ethnography that while official, macro-level policies can open up what Hornberger (2006, p. 223) later called “ideological and implementational spaces” of opportunity for multilingual education, those policies are not unproblematically adopted by local social actors and may fail without sufficient local-level support.

Building on Hornberger’s work, King (2001) used ethnography to examine revitalization prospects for Quichua in Ecuador. Adopting an ethnography of communication approach, King compared two Quichua communities, one (urban) in which a shift to Spanish was advanced and another (rural) that was rapidly moving from Quichua to Spanish. Despite Ecuador’s official policy of bilingual intercultural education, for members of both communities, “Quichua remain[ed] on the periphery of their daily lives” (p. 185). The school affords “an important foothold” for Quichua maintenance, King concluded, particularly by dispelling “pervasive notions that indigenous languages are inferior and inadequate” and thereby increasing the language’s status (pp. 182–183), but schools alone are insufficient to overcome the extreme economic and social pressures favoring Spanish.

Based on ethnographic research conducted over a 20-year period in the Navajo (Diné) community of Rough Rock, McCarty (2002) analyzed the interaction of federal Indian policy with bilingual-bicultural program implementation in the first American Indian community-controlled school. Through a fortuitous and fleeting alignment of top-down government legislation and grassroots Indigenous political activism, Rough Rock emerged as the first Native American community-controlled school and one of the first contemporary schools to teach in and through an Indigenous language. Like Hornberger’s and King’s ethnographies, this study showed that while bilingual-bicultural schooling in itself is insufficient to sustain the Indigenous language as a child language, such schooling is nonetheless a crucial resource for the exercise of Indigenous linguistic, cultural, and political self-determination.

Since the 1990s, many scholars have taken an ethnographic approach to the study of language and literacy policy. In chronological order, key studies include:

- Davis’s (1994) ethnography of communication in multilingual Luxembourg;
- May’s (1994) research on Māori educational reform at Richmond Road School in Aotearoa/New Zealand;
- Freeman’s (1998) discourse-analytic study of the successful Oyster Bilingual School in Washington, DC;
- Aikman’s (1999) exploration of intercultural education and mother tongue literacy among the Arakmbut in the Peruvian Amazon;
- Heller’s (1999) sociolinguistic ethnography of French-speaking adolescents in English-speaking Canada;
- Jaffe’s (1999) study language politics in Corsica;

- Patrick’s (2003) investigation of Indigenous-language persistence in a quadrilingual Inuktitut-Cree-French-English community in Arctic Québec;
- Ramanathan’s (2005) critical ethnography of vernacular-medium education in Gujarat;
- Blommaert’s (2008) study of the chasm between “grassroots” and elite literacies in the Democratic Republic of the Congo;
- Meek’s (2010) ethnography of language revitalization among the Kaska in northern Canada; and
- Wyman’s (2012) analysis of Yup’ik youth culture and language endangerment in Alaska.

Multiple edited volumes using ethnographic approaches have provided what Hymes (1980) called “contrastive insight” to these individual case studies.

The linguistic anthropology of education, introduced by Stanton Wortham and Betsy Rymes (2003), and the sociocultural linguistics proposed by Mary Bucholtz and Kira Hall (2008) have built on these foundations, emphasizing the ethnographic study of language use in practice and a “progressive-political commitment” to research on minoritized languages (Bucholtz and Hall 2008, p. 423). At the same time, the anthropology of policy, introduced and developed by Cris Shore and Susan Wright (1997, 2011), has spawned new ways of conceptualizing and investigating policy. “The study of policy,” Shore and Wright (1997) point out, “leads straight into issues at the heart of anthropology: knowledge and power, rhetoric and discourse, meaning and interpretation, the global and the local” (p. 4). Subsequent explorations of education policy from a critical sociocultural perspective include Sutton and Levinson’s (2001) seminal *Policy as Practice*, Hamann’s (2003) *The Educational Welcome of Latinos in the New South*, and Stein’s (2004) *The Culture of Education Policy*. In tandem with these research currents is a burgeoning ethnographic literature in educational linguistics (e.g., Bigelow and Ennser-Kananen 2015). Naming these analyses the “ethnography of language policy,” Hornberger and Johnson (2007) stress its attention to human agency and the “varying local interpretations, implementations, and perhaps resistance” (p. 51).

---

## Work in Progress

Two simultaneous and seemingly paradoxical twenty-first-century forces shape current ethnographic work in educational linguistics. On the one hand is intensified (trans)migration linked to massive global flows of information, capital, and technology and to deepening economic, political, and ideological polarities driving whole populations from their homelands. These processes create what scholars have called “super-diversity” (Arnaut et al. 2016): globalized urban neighborhoods and virtual spaces characterized by multilayered, crisscrossing cultural, linguistic, religious, national, and racial/ethnic identifications. On the other hand is the mounting worldwide endangerment of human linguistic and cultural diversity, as the same globalizing forces serve to standardize and homogenize, even as they stratify and

marginalize. Language endangerment is particularly grave for Indigenous peoples, who, although they constitute 5% of the world's population, speak 75% of the world's languages.

These processes call for rethinking anthropological notions of culture in ways that recognize that “multiple cultures can exist in one space and...one culture can be produced in different spaces” and for reconceptualizing language as mobile sociolinguistic resources and repertoires (Blommaert 2011, p. 63). This in turn has implications for our understandings of what constitutes speakerhood, language fluency, and speech communities. As Moore (2012) describes the issues, the existence of both super-diversity and language endangerment “complicate inherited notions of the unitary, fully fluent...native speaker as...the normal starting point for description and analysis” (p. 59).

The simultaneity of super-diversity and language endangerment also complicates the micro-/macro-analytical distinctions discussed in previous sections and related conceptions of the local and the global. In a theme issue of *Anthropology and Education Quarterly*, Wortham (2012) suggests that micro and macro have outlived their utility as explanatory tools and argues for pushing beyond these heuristics to engage more directly with “complex multiscale realities” (p. 135). In example of this, Warriner (2012), in the same theme issue, presents a study of the language ideologies of refugee women in a US English-as-a-second-language program. Her fine-grained analysis of the women's life narratives shows how these micro-level speech acts interrupt oppressive macro-level ideological, historical, and institutional constraints on their language practices and life opportunities.

A related stream of ethnographic work has investigated the ways in which globalizing forces are taken up and reconfigured in local language practices and ideologies – what Hornberger and McCarty (2012) call “globalization from the bottom up.” In an ethnographic analysis of bilingual education in Mozambique, for example, Chimbutane and Benson (2012) show how local appropriations of top-down curricular reforms open up new spaces for the promotion of Indigenous languages and cultures. Working in a South African undergraduate language program, Joseph and Ramani (2012) show similarly how a focus on additive multilingualism in teacher preparation can unseat the hegemony of English within the “new globalism.” In these and other ethnographic cases, relatively small-scale education reformulations create new options through which marginalized languages historically constructed as “traditional” (and hence not useful in the global economy) can be repositioned and resignified as “modern” (Joseph and Ramani 2012, p. 32).

Recent youth language research further illuminates these multiscale realities and their implications for the ethnography of language policy. Recognizing that youth, like adults, act as agents, this research examines youth's “emic views, language ideologies, and identities [to] provide insights into how social and political processes are lived and constructed through language use” (Wyman et al. 2014, p. 6). Paris (2011), for example, looked at youth language practices in a multiethnic high school in the western USA. Building on Rampton's (1995) classic ethnographic study of youth linguistic “crossing,” Paris (2011) explored language sharing – “momentary and sustained uses of...the language traditionally ‘belonging’ to another group [and]

ratified as appropriate by its traditional speakers” (p. 14). Understanding such processes, Paris maintains and helps us see the sociocultural, sociopolitical, and sociolinguistic forces that alternately reinforce or cut across ethnic divisions “toward spaces of interethnic unity,” a requirement for a pluralistic society (p. 16).

This research also foregrounds the ways in which youth “translanguage,” a term used by García (2009) to explain the heteroglossic language practices she observed in urban bilingual classrooms. Translanguaging goes beyond code switching and involves the “multiple discursive practices in which bilinguals engage in order to make sense of their bilingual worlds” (García 2009, p. 44). Ethnographic research with Indigenous youth shows the salience of this construct and related notions of linguistic hybridity and heteroglossia for understanding dynamic processes of language shift and endangerment. In a large-scale study of Indigenous youth language ideologies and practices, McCarty et al. (2014) found that, contrary to educators’ perceptions of youth as disinterested in their heritage language and of Indigenous languages as largely absent from their daily lives, Native youth are growing up in highly complex sociolinguistic environments that include multiple languages and language varieties to which they have differential exposure – sociolinguistic resources that often go undetected or are stigmatized in school. At the same time, the complex ideological processes in these dynamic sociolinguistic environments may foster a *de facto* language policy that discourages opportunities for young people’s acquisition of their heritage language. Studies by Nicholas (2014) with Hopi youth, Lee (2014) with Navajo and Pueblo youth and young adults, Messing 2014 with Mexicano (Nahuatl) young adults, and Wyman (2012) with Yup’ik youth in Alaska similarly show how young people translanguage and negotiate “mixed messages” about the value of their heritage language in rapidly changing sociolinguistic environments.

These studies problematize another set of binaries: “speaker” versus “nonspeaker,” “fluent” versus “nonfluent,” and “extinct” versus “living” with reference to languages. The studies also provide nuanced ethnographic portraits of the often “closeted” multilingual repertoires of Indigenous and minoritized youth. As Wyman et al. (2014) write, these studies demonstrate the fallacy of deficit assumptions of youth linguistic practices, highlighting “how young people can activate and strategically deploy ‘unfinished’ linguistic competences to make claims to local and ethnic belonging” (p. xv).

Several additional lines of ethnographic inquiry are important. The first concerns the lingering debate on the role of schools in structuring diversity in complex sociolinguistic ecologies and whether schools can serve as resources for the reclamation and maintenance of endangered mother tongues. Since Hornberger’s groundbreaking (1988) ethnographic study of these issues for Quechua in Peru, a great deal of ethnographic effort has been poured into answering this question. It seems clear from this research that, while schools cannot substitute for intergenerational language transmission in the family, when aligned with other social institutions, schools can reinforce family- and community-based efforts (Hornberger 2008). Moreover, there are few examples of successful language revitalization in which schools have not played a prominent role.

A recent strand of research asks whether schools can promote the dual goals of language revitalization and enhanced academic achievement among Indigenous and other minoritized students. Drawing on ethnographic research at the Rakaumangananga School in Aotearoa/New Zealand, Hill and May (2011) show the efficacy of high levels of Māori-language immersion alongside careful planning of English-language instruction in achieving the goal of full Māori-English bilingualism and biliteracy. This research also demonstrates the value of building on Indigenous/minoritized students' linguistic hybridity as a resource rather than treating hybridity as a liability in school.

A third line of inquiry concerns the role of education practitioners in the language planning and policy process. A decade after Ricento and Hornberger (1996) placed English-language teaching professionals at the center of the LPP "onion," Ramanathan and Morgan (2007) offered a reconsideration of the "everyday contexts in which [language] policies are interpreted and negotiated" (p. 447). Emphasizing practitioner agency and a view of official policies as "multifaceted signs. . . whose interpretations and enactments rest in our hands," these comparative case studies afford "glimpses into complex interplays between policies, pedagogic practices, instructional constraints, and migrations" (Ramanathan and Morgan 2007, p. 451, 459). A growing body of ethnographic research positions educators "at the epicenter" of language planning and policymaking, as researchers move "beyond top-down, bottom-up, or even side-by-side divisions to a conceptualization of language policy as a far more dynamic, interactive, and real-life process" (Menken and García 2010, p. 4).

Another recent extension of the ethnography of language policy investigates the inner workings of language academies in structuring minoritized-language status, corpus, and acquisition planning. In a 2015 study, Coronel-Molina examined these processes for Quechua in Peru. Noting that archival research "can never tell the whole story" (p. 6), Coronel-Molina's ethnography of the High Academy of the Quechua Language reveals the consequential impacts of the micro interactions, attitudes, and ideologies of Academy members on the acquisition and development of Quechua.

Finally, scholars have begun to look more closely at the de facto policymaking about language use in the private and intimate domain of family homes (King et al. 2008). Because parents' beliefs about language have significant impacts on children's language choices and practices, family language policy (FLP) as a subfield is crucial in understanding children's language acquisition, ideologies, and identity construction. Defined as "explicit and overt planning in relation to language use" (King et al. 2008, p. 907), FLP explores how parents choose to use and teach a language to their children and how their ideologies about language shape their children's language practices in the home environment. Within the family domain, parents' beliefs about language affect what home language they will use and how they make this choice. Furthermore, the political, economic, cultural, and sociolinguistic ecology inside and outside the home also greatly influences these language choices and how languages are transmitted across generations, maintained, or lost.

All of this research contributes to what scholars have called the New Language Policy Studies, a paradigmatic shift away from conventional treatments of policy as

disembodied text to a view of policy as a situated sociocultural process (McCarty et al. 2012). Influenced by Hymes's (1980) emphasis on "ethnographic monitoring" and on language in use, this theoretical perspective helps us understand the bases of linguistic inequalities in education. Perhaps even more importantly, this critical sociocultural, processual view of language policy guides us to new possibilities for transforming those inequalities.

---

## Problems and Difficulties

Ethnography relies on the assumption that researchers' "first-hand observation, sophisticated research instruments, and scholarly training will ensure an 'authentic' representation" of language practices, processes, and policies (Canagarajah 2006, p. 156). Yet, as a form of qualitative inquiry, ethnography has been questioned as failing to provide "objective" and "value-free" description and interpretation. This brings into sharp focus the fact that any ethnographic account, no matter how rich in description, is by necessity partial and perspectival. Not only can ethnographers not attend to every single detail in fieldwork (nor is this desirable), what an individual ethnographer chooses to focus on and edit out is steeped in her or his disciplinary training, subject position, and research questions. Thus, ethnographers must constantly exercise reflexivity, the critical interrogation of one's own subject position and the power relations in which the research endeavor is steeped. According to Canagarajah (2006), this methodological stance aligns with the growing body of work in critical ethnography, which recognizes that all knowledge is socially constructed and "implicated in power relations" (p. 156).

An even more consequential challenge may be ethnography's utility in transforming the linguistic hierarchies it exposes. As ethnographic research illuminates the multilevel processes through which these hierarchies are structured, can it also shed light on windows of policymaking opportunity whereby linguistic inequalities may be contested and transformed? As Johnson (2013) writes in a theme issue on the ethnography of language policy, this is both an ongoing challenge and an opportunity, as the ethnography of language policy balances "a critical understanding of the hegemony of policy" with an "understanding of the power of language policy actors" to interpret, appropriate, and transform repressive language policies (p. 2).

---

## Future Directions

From Boas's and Malinowski's early attention to ethnographic fieldwork, to the ethnography of communication, to recent work addressing the "complex multiscale realities" (Wortham 2012) of super-diversity, language endangerment, and practitioners' roles in the language planning and policymaking "onion," ethnography has afforded rich, multilayered insights into the ways in which linguistic diversity is constructed as a problem or a resource in schools and society. Those insights stem from a distinctive "way of seeing" policy processes through a holistic, cultural lens

and a “way of looking” at those processes firsthand, up close, over extended periods of time, and from participants’ point of view. By “casting an ethnographic eye on language . . . at the individual, classroom, school, community, regional, national, and global levels,” Hornberger and Johnson (2007) observe, researchers can “uncover the indistinct voices, covert motivations, embedded ideologies, invisible instances, or unintended consequences” of language policies and pedagogies as they are manifested in particular sociocultural and educational contexts (p. 24).

In an era of growing global diversity, we are witness to language education policies designed to curb and control that diversity through reductive literacy practices and the exclusion of nondominant languages as media of instruction in schools. In this political and educational climate, ethnography and other qualitative approaches to inquiry are often marginalized in official policy discourse. Yet ethnography and ethnographers have crucial roles to play in this policy environment. As a form of knowledge production, ethnography is intrinsically democratizing, as its primary goal – to “learn the meanings, norms, and patterns of a way of life” (Hymes 1980, p. 98) – is what people do every day. Ethnography therefore has the potential to break down hierarchies between the “knower” and the “known” and to bring local stakeholders – education practitioners and community members – directly into the research process.

This commitment to praxis represents the third pillar in the contributions of ethnography to language policy – a clear value position that puts ethnography to work in transforming linguistic inequalities (Wyman et al. 2014). This “way of being” a researcher intentionally dislodges allegedly value-free methodologies, replacing them with grounded forms of collaborative, reflexive, and critical inquiry. Taking such a research stance requires that ethnographers work in partnership with local stakeholders, using the unique tools of our discipline to illuminate not only the injustices in language education but also the concrete possibilities for positive change.

---

## Cross-References

- ▶ [Critical Ethnography](#)
- ▶ [Ethnography and Language Education](#)

---

## Related Articles in the Encyclopedia of Language and Education

- Kendall A. King: [Family Language Policy](#). In Volume: Language Policy and Political Issues in Education
- Munene Mwaniki, Beatriz Arias, and Terrence Wiley: [Bilingual Education Policy](#). In Volume: Bilingual and Multilingual Education
- Stanton Wortham and Sabina Perrino: [Linguistic Anthropology of Education](#). In Volume: Discourse and Education



Stephen May: [Bilingual Education: What the Research Tells Us](#). In Volume: Bilingual and Multilingual Education

---

## References

- Aikman, S. (1999). *Intercultural education and literacy: An ethnographic study of indigenous knowledge and learning in the Peruvian Amazon*. Amsterdam: John Benjamins.
- Arnaut, K., Blommaert, J., Rampton, B., & Spotti, M. (Eds.). (2016). *Language and superdiversity*. London: Routledge.
- Bigelow, M., & Ennser-Kananen, J. (Eds.). (2015). *The Routledge handbook of educational linguistics*. New York: Routledge.
- Blommaert, J. (2008). *Grassroots literacy: Writing, identity and voice in Central Africa*. London: Routledge.
- Blommaert, J. (2011). *The sociolinguistics of globalization*. Cambridge, UK: Cambridge University Press.
- Blommaert, J., & Jie, D. (2010). *Ethnographic fieldwork: A beginner's guide*. Bristol: Multilingual Matters.
- Bucholtz, M., & Hall, K. (2008). All of the above: New coalitions in sociocultural linguistics. *Journal of Sociolinguistics*, 12(4), 401–431.
- California State Department of Education. (1986). *Beyond language: Social and cultural factors in schooling language minority students*. Los Angeles: Evaluation, Dissemination and Assessment Center, California State University Los Angeles.
- Canagarajah, S. (2006). Ethnographic methods in language policy. In T. Ricento (Ed.), *An introduction to language policy: Theory and method* (pp. 151–169). Malden: Blackwell.
- Cazden, C. B., John, V. P., & Hymes, D. (1972). *Functions of language in the classroom*. New York: Teachers College Press.
- Chimbutane, F., & Benson, C. (2012). Expanded spaces for Mozambican languages in primary education: Where bottom-up meets top-down. *International Multilingual Research Journal*, 6(1), 8–21.
- Coronel-Molina, S. M. (2015). *Language ideology, policy and planning in Peru*. Bristol: Multilingual Matters.
- Darnell, R. (1998). *And along came Boas: Continuity and revolution in Americanist anthropology*. Amsterdam: John Benjamins.
- Davis, K. A. (1994). *Language planning in multilingual contexts*. Amsterdam: John Benjamins.
- Duranti, A. (2003). Language as culture in U.S. anthropology: Three paradigms. *Current Anthropology*, 44(3), 323–347.
- Foley, D. (2005). Enrique Trueba: A Latino critical ethnographer for the ages. *Anthropology and Education Quarterly*, 36(1), 354–366.
- Freeman, R. (1998). *Bilingual education and social change*. Clevedon: Multilingual Matters.
- Garcia, O. (2009). *Bilingual education in the 21st century: A global perspective*. Malden: Wiley-Blackwell.
- Green, J., & Wallat, C. (Eds.). (1981). *Ethnography and language in educational settings*. Norwood: Ablex.
- Gumperz, J., & Hymes, D. (Eds.). (1972). *Directions in sociolinguistics: The ethnography of communication*. New York: Holt, Rinehart and Winston.
- Hamann, E. T. (2003). *The educational welcome of Latinos in the New South*. Westport: Praeger.
- Heath, S. B. (1983). *Ways with words*. Cambridge, UK: Cambridge University Press.
- Heller, M. (1999). *Linguistic minorities and modernity: A sociolinguistic ethnography*. London: Longman.

- Hill, R., & May, S. (2011). Exploring biliteracy in Māori-medium education: An ethnographic perspective. In T. L. McCarty (Ed.), *Ethnography and language policy* (pp. 161–183). New York: Routledge.
- Hornberger, N. H. (1988). *Bilingual education and language maintenance: A southern Peruvian Quechua case*. Dordrecht: Foris.
- Hornberger, N. H. (2003). Linguistic anthropology of education (LAE) in context. In S. Wortham & B. Rymes (Eds.), *Linguistic anthropology of education* (pp. 245–270). Westport: Praeger.
- Hornberger, N. H. (2006). *Nichols to NCLB*: Local and global perspectives on U.S. language education policy. In O. García, T. Skutnabb-Kangas, & M. E. Torres-Guzmán (Eds.), *Imagining multilingual schools* (pp. 223–237). Clevedon: Multilingual Matters.
- Hornberger, N. H. (Ed.). (2008). *Can schools save indigenous languages? Policy and practice on four continents*. New York: Palgrave Macmillan.
- Hornberger, N. H., & Johnson, D. C. (2007). Slicing the onion ethnographically: Layers and spaces in multilingual language education policy and practice. *TESOL Quarterly*, 41(3), 509–532.
- Hornberger, N. H., & McCarty, T. L. (Guest Eds.) (2012). Globalization from the bottom up: Indigenous language planning and policy across time, space, and place. [Special Issue]. *International Multilingual Research Journal*, 6(1), entire.
- Hymes, D. (1980). *Language in education: Ethnolinguistic essays*. Washington, DC: Center for Applied Linguistics.
- Jaffe, A. (1999). *Ideologies in action: Language politics on Corsica*. Berlin: Mouton de Gruyter.
- Johnson, D. C. (2013). Introduction: Ethnography of language policy. *International Journal of the Sociology of Language*, 219, 1–6.
- Joseph, M., & Ramani, E. (2012). “Glocalization”: Going beyond the dichotomy of global versus local through additive multilingualism. *International Multilingual Research Journal*, 6(1), 22–34.
- King, K. A. (2001). *Language revitalization processes and prospects: Quichua in the Ecuadorian Andes*. Clevedon: Multilingual Matters.
- King, K. A., Fogle, L., & Logan-Terry, A. (2008). Family language policy. *Language and Linguistics Compass*, 2(5), 907–922.
- Lee, T. S. (2014). Critical language awareness among Native Youth in New Mexico. In L. T. Wyman, T. L. McCarty, & S. E. Nicholas (Eds.), *Indigenous youth and multilingualism: Language identity, ideology, and practice in dynamic cultural worlds* (pp. 130–148). New York: Routledge.
- May, S. (1994). *Making multicultural education work*. Clevedon: Multilingual Matters.
- McCarty, T. L. (2002). *A place to be Navajo: Rough Rock and the struggle for self-determination in Indigenous schooling*. Mahwah: Lawrence Erlbaum.
- McCarty, T. L. (Ed.). (2011). *Ethnography and language policy*. New York: Routledge.
- McCarty, T. L. (2015). Ethnography in educational linguistics. In M. Bigelow & J. Enns-Kananen (Eds.), *The Routledge handbook of educational linguistics* (pp. 23–37). New York: Routledge.
- McCarty, T. L., Collins, J., & Hopson, R. K. (2012). Dell Hymes and the New Language Policy Studies: Update from an underdeveloped country. *Anthropology and Education Quarterly*, 42(4), 335–363.
- McCarty, T. L., Romero-Little, M. E., Warhol, L., & Zepeda, O. (2014). Genealogies of language loss and recovery: Native youth language practices and cultural continuance. In L. T. Wyman, T. L. McCarty, & S. E. Nicholas (Eds.), *Indigenous youth and multilingualism: Language identity, ideology, and practice in dynamic cultural worlds* (pp. 26–47). New York: Routledge.
- Mead, M. (1928[1961]). *Coming of age in Samoa*. New York: William Morrow and Co.
- Meek, B. (2010). *We are our language: An ethnography of language revitalization in a Northern Athabaskan Community*. Tucson: University of Arizona Press.
- Menken, K., & García, O. (Eds.). (2010). *Negotiating language policy in schools: Educators as policy makers*. New York: Routledge.
- Messing, J. (2014). “I didn’t know you spoke Mexicano!”: Shifting ideologies, identities, and ambivalence among former youth in Tlaxcala, Mexico. In L. T. Wyman, T. L. McCarty, & S. E.

- Nicholas (Eds.), *Indigenous youth and multilingualism: Language identity, ideology, and practice in dynamic cultural worlds* (pp. 111–129). New York: Routledge.
- Moore, R. (2012). Taking up speech in an endangered language: Bilingual discourse in a heritage language classroom. *Working Papers in Educational Linguistics*, 27(2), 57–78.
- Nicholas, S. (2014). “Being” Hopi by “living” Hopi: Redefining and reasserting cultural and linguistic identity – Emergent Hopi youth ideologies. In L. T. Wyman, T. L. McCarty, & S. E. Nicholas (Eds.), *Indigenous youth and multilingualism: Language identity, ideology, and practice in dynamic cultural worlds* (pp. 70–89). New York: Routledge.
- Paris, D. (2011). *Language across difference*. Cambridge, UK: Cambridge University Press.
- Patrick, D. (2003). *Language, politics, and social interaction in an Inuit community*. Berlin: Mouton de Gruyter.
- Philips, S.U. (1993[1983]) *The invisible culture: Communication in classroom and community on the Warm Springs Indian Reservation*. Prospect Heights: Waveland.
- Pike, K. (1967). *Language in relation to a unified theory of the structure of human behavior* (2nd ed.). The Hague: Mouton.
- Ramanathan, V. (2005). *The English-vernacular divide: Postcolonial language politics in practice*. Clevedon: Multilingual Matters.
- Ramanathan, V., & Morgan, B. (2007). TESOL and policy enactments: Perspectives from practice. *TESOL Quarterly*, 41(3), 447–463.
- Rampton, B. (1995). *Crossing: Language and identity among adolescents*. Manchester: St. Jerome Publishing.
- Ricento, T. K., & Hornberger, N. H. (1996). Unpeeling the onion: Language planning and policy and the ELT professional. *TESOL Quarterly*, 30(3), 401–427.
- Shore, C., & Wright, S. (Eds.). (1997). *Anthropology of policy: Critical perspectives on governance and power*. London: Routledge.
- Shore, C., & Wright, S. (Eds.). (2011). *Policy worlds: Anthropology and the analysis of contemporary power*. New York: Berhahn Books.
- Spindler, G. (Ed.). (2000). *Fifty years of anthropology and education 1950–2000*. Mahwah: Lawrence Erlbaum.
- Stein, S. (2004). *The culture of education policy*. New York: Teachers College Press.
- Street, B. V. (1984). *Literacy in theory and practice*. Cambridge, UK: Cambridge University Press.
- Sutton, M., & Levinson, B. A. U. (Eds.). (2001). *Policy as practice: Toward a comparative sociocultural analysis of educational policy*. Westport: Ablex.
- Trueba, H. T., Guthrie, G., & Au, K. (Eds.). (1981). *Culture and the bilingual classroom: Studies in classroom ethnography*. Rowley: Newbury House.
- Warriner, D. S. (2012). When the macro facilitates the micro: A study of regimentation and emergence in spoken interaction. *Anthropology and Education Quarterly*, 43(2), 173–191.
- Wolcott, H. F. (2008). *Ethnography: A way of seeing* (2nd ed.). Lanham: Rowman and Littlefield.
- Wortham, S. (2012). Beyond macro and micro in the linguistic anthropology of education. *Anthropology and Education Quarterly*, 43(2), 128–137.
- Wortham, S., & Rymes, B. (Eds.). (2003). *Linguistic anthropology of education*. Westport: Praeger.
- Wyman, L. T. (2012). *Youth culture, language endangerment and linguistic survivance*. Bristol: Multilingual Matters.
- Wyman, L. T., McCarty, T. L., & Nicholas, S. E. (Eds.). (2014). *Indigenous youth and multilingualism: Language identity, ideology, and practice in dynamic cultural worlds*. New York: Routledge.

---

# Researching Historical Perspectives on Language, Education, and Ideology

Thomas Ricento

---

## Abstract

In this article, I focus on aspects of ideology which relate to education and the social processes, relations, and especially social hierarchies which are reflected in and produced through ideologies of language. As Woolard and Schieffelin (*Annual Review of Anthropology* 23, 55–56, 1994) note, ideologies of language “...envision and enact links of language to group and personal identity, to aesthetics, to morality, and to epistemology.” Some of the key ideologies that are considered in this article are (1) the verbal deprivation construct, (2) the ideology of individualism, (3) the ideology of English monolingualism, (4) the standard language ideology, and (5) the ideology of the native speaker. Conceptual and empirical challenges to these widely accepted social constructs by critical scholars in applied linguistics and related disciplines are presented; these scholars have used a variety of theoretical and methodological approaches to debunk ideologies in which individuals and attributes of their language and “culture” are blamed for deficiencies in school performance, while systemic institutional factors that marginalize “nonmainstream” individuals, including the language/language variet(ies) they use, are downplayed or ignored. Ethnic, racial, and gender bias may correlate with the marginalization of language minorities in various contexts, whether or not an individual from a marginalized group speaks a “standard” version of the dominant/national language. Innovation in research methods over the past decade has provided more fine-grained tools to investigate relations between language policies and the social actions of individuals; examples of such methods include nexus analysis and scale analysis.

---

T. Ricento (✉)

Werklund School of Education, University of Calgary, Calgary, AB, Canada

e-mail: [tricento@ucalgary.ca](mailto:tricento@ucalgary.ca)

---

**Keywords**

Critical discourse analysis • English monolingualism ideology • Ideologies of language • Native speaker ideology • Standard language ideology • Verbal deprivation theory

**Contents**

Introduction .....	68
Early Developments .....	69
Major Contributions .....	70
Work in Progress .....	74
Problems and Difficulties .....	76
Future Directions .....	78
Cross-References .....	78
Related Articles in the Encyclopedia of Language and Education .....	79
References .....	79

---

**Introduction**

This article considers research on language ideologies and the relevance of this work for educational contexts. To be sure, the amount of theorizing and empirical investigation on the topic of language ideologies published just over the past several decades is substantial; therefore, I will focus only on particular aspects of this topic which relate to education and the social processes, relations, and especially social hierarchies which are reflected in and produced through ideologies of language. In doing so, I will have to leave out much of the theoretical work from the literatures of anthropology, critical theory, philosophy, political science, sociolinguistics, cultural studies, among other areas that could be cited.

As Woolard and Schieffelin (1994, pp. 55–56) point out, ideologies of language “are not only about language. Rather, such ideologies envision and enact links of language to group and personal identity, to aesthetics, to morality, and to epistemology.” Language and languages are not simply “conveyor belts” for transmitting information between human interactants; rather, they are complex systems which perform a number of social functions, including signaling who we are (i.e., information about where we were born or raised, how much education we have had, our social skills, the group(s) we wish to be identified with, and so on). One of the primary socializing environments in most societies is formal schooling.

Schools are places where young children are taught the “correct,” usually dominant “standard,” language, where they may come into contact with students from different cultural and/or linguistic backgrounds, and in multicultural and multilingual settings, they are likely to begin to develop identities which include an awareness of the relative social status of the language(s) they use (or do not use). If the child’s home language variety is the same as that spoken and written at school, the transition from home to school with regard to linguistic identity is not usually a problem; however, when the home variety is substantially different from the school

variety, and the home variety is stigmatized as “nonstandard” or deficient, the mismatch can lead to problems. The assumption that the “standard” variety of the dominant (often national or regional) language is “better” than, more “logical” than, and more “pure” than the “nonstandard” variety is an example of one of the most ubiquitous and powerful language ideologies around the world.

---

## Early Developments

Questions surrounding language are almost never exclusively about language, *per se*. They are very often concerned with identities, both ascribed and achieved, in particular sociohistorical contexts. Scholars have identified the rise of the modern nation-state beginning in the eighteenth century in Europe as the primary factor in the association of a particular language with a particular ethnic group living within a geographically contiguous, politically defined area. Johann Gottlieb Fichte, the German metaphysician who championed the cultural and linguistic uniqueness of the German *Volk*, famously said: “Wherever a separate language is found, there is also a separate nation which has the right to manage its affairs. . . and to rule itself” (cited in Inglehart and Woodward 1992, p. 410). The roots of the language/nation nexus, of course, extend far back into antiquity; in the third century BC, Ashoka, India’s Buddhist Emperor, pursued political unification through linguistic toleration, whereas Qin Shi Huangdi, the first emperor of a united China, suppressed regional scripts and selected a single standardized writing variety and mandated its use (cited in Lo Bianco 2004, p. 745). Dante Alighieri (1265–1321) chose to write his greatest work, *La Divina Commedia*, in his native Tuscan variety of Italian rather than in the customary Latin and in so doing brought to the fore the *questione della lingua* (“language question”), a debate that runs through the entire course of modern Italian history. The “language question” continues to intrude in all aspects of social life in the contemporary world. Questions and conflicts about which language or language variety is valued (or not valued), taught (or not taught) in school, and used (or not used) for different functions in different domains often are implicated in deadly conflicts between groups with historical reasons for not wanting to share territory, power, and/or resources.

Some of the most important early research by sociolinguists with implications for language ideology in education was done by William Labov. In his now classic essay “The Logic of Nonstandard English” (1972), Labov debunked the verbal deprivation theory promoted by psychologists (e.g., Bereiter and Engemann 1966) which claimed, among other things, that African American children in the USA come to school without sufficient verbal ability to succeed. Bereiter et al. (1966, pp. 112–113), based on a study of 4-year-old black children from Urbana, Illinois, claim that their communication was by gestures, “single words,” and “a series of badly connected words or phrases.” He describes their speech as “the language of culturally deprived children . . . [that] is not merely an underdeveloped version of standard English, but is a basically nonlogical mode of expressive behavior.” Labov argued that the idea of verbal deprivation has no basis in social reality and that black children in the urban ghettos receive a lot of verbal

stimulation and participate in a highly verbal culture. He claimed that the psychologists' lack of understanding of linguistics along with poor experimental design and methodology resulted in a fundamental misreading and misinterpretation of the verbal abilities of black children.

Another early landmark study was conducted by Ray Rist (1970). In a 2.5-year longitudinal study of a single group of African American kindergarten children, Rist found that the teacher developed expectations of the academic potential and abilities of each student based on her subjective evaluation of that student's oral language. Importantly, students judged by the teacher to be "fast learners" (placed at the first of three tables) were quite verbal and displayed a greater use of Standard American English within the classroom compared to children at the other tables, who usually responded to the teacher in black dialect (p. 420). The children more adept at "school language" were viewed by the teacher as more capable and more likely to succeed in school and life, despite the fact that IQ test scores indicated no statistically significant differences among the children at the three tables. Students labeled as "slow learners" were unable to move up in their reading groups even if their performance in reading warranted such a change in classification. All the children in the class and the teacher were African American. Despite this shared cultural background, differences in socioeconomic class appeared to correlate with students' placement in reading groups. Rist concludes that "the child's journey through the early grades of school at one reading level and in one social grouping appeared to be pre-ordained from the eighth day of kindergarten" (p. 435).

To summarize, research in the 1960s by some psychologists (e.g., Bereiter and Engelmann 1966; Jensen 1969) and sociologists (e.g., Basil Bernstein 1966) placed the blame for school failure on minority children who were characterized as having a variety of cognitive deficits, especially with regard to their language abilities. Other researchers from linguistics and anthropology located the problem not in the children but in the relations between them and the school system. This position found that, for example, inner-city children differ from the standard culture of the classroom and that these differences (in language, family style, and ways of living) are not always understood by teachers and psychologists. This research leads scholars in the social sciences and education to examine the nature of ideologies about language and how these ideologies impacted the school experiences of different groups defined in terms of socioeconomic status, ethnicity, race, and/or language or language variety spoken. In the decades following the groundbreaking research described earlier, researchers used a variety of research methods (especially ethnographic and discourse analytic techniques) to better understand the impact of ideologies on educational practices and policies from the classroom to the national policy-making level.

---

## Major Contributions

As suggested by the studies described earlier, a major contribution in applied linguistics and educational research over the last 50 years or so has been the critical examination of the causes of social inequality and how language (often implicitly)

plays a role in maintaining such inequalities. Scholars in the field of language policy (e.g., Pennycook 1994; Phillipson 1992; Tollefson 1991) have relied on theories developed by thinkers such as Bourdieu (1991), Foucault (1972), Gramsci (1988), and Habermas (1975) among many others to develop models to explain how language is imbricated in all aspects of social life and how it plays a central role in the establishment and maintenance of social control by powerful elites. However, despite the critical turn in research in language policy, educational policies and practices in most parts of the world continue to be informed by ideologies about language, which can be detrimental to the achievement of greater educational access for many language minority groups.

Critical scholars, in analyzing the causes for the persistence of educational programs and practices which (in their view) are relatively ineffective in closing the educational and economic gaps between dominant (majority language) groups and marginalized (minority language) groups in many settings around the world, have identified ideologies which often inform such programs and practices. Methods of analysis used include discourse analysis of both spoken and written language in the communication and reproduction of racism (e.g., van Dijk 1984; Wodak and Reisigl 2003), in gender bias (e.g., Corson 1993; Matsui 1995; McGregor 1998), and in the marginalization of language minorities in various contexts (e.g., Tollefson 1991; Ricento 2005b). An example of a study which employs a historical analysis in the US context is Wiley and Lukes (1996), who describe three ideologies which, together, inform social and educational policies which tend to marginalize speakers of minority languages in US classrooms. The first is the “ideology of individualism.” This ideology is evident in research in second language acquisition, which assumes that the variables which are involved in second language acquisition (or the acquisition of a standard variety of a language) are located entirely within the individual. An important effect of this view is that motivation – and lack thereof – is viewed by practitioners and policy makers as something an individual has or does not have. A person’s class, racial, or linguistic characteristics (achieved or ascribed) are seen as largely irrelevant to his or her motivation or prospects for social mobility. Scholars in second language acquisition (e.g., Norton 2000; Ricento 2015) have conducted ethnographic research among immigrant populations and found that learners’ identities influence motivation and, ultimately, acquisition of a second language. Rather than viewed as a constant or fixed trait, researchers have shown that identity (and motivation) is a “contingent process involving dialectic relations between learners and the various worlds and experiences they inhabit and which act on them” (Ricento 2005a, p. 895).

The second ideology described by Wiley and Lukes is the “ideology of English monolingualism” (in the US context, but it applies to other languages in other polities as well). This ideology reflects the view that language diversity is essentially something imported as a result of immigration. The “normal” situation in the USA, according to this ideology, is English monolingualism. Thus, a language such as Spanish, which existed within what is now the continental USA prior to and after the declaration of independence from England, is characterized as a “foreign” language rather than an “American” language, which it demonstrably is. This ideology



informs the 25-year-old movement to ban bilingual education programs (with many “successes” along the way) and federal and state initiatives to declare English as the (only) official language of a state or the USA. Research by Veltman (1983) using US census data from 1940, 1960, and 1970 found a dramatic shift from minority languages to English as evidence that assimilation to virtual English monolingualism was beginning in the second generation and nearly completed by the third generation among immigrant populations in the USA. More recently, Rumbaut et al. (2006, p. 458), relying on data from two published studies and a survey they conducted themselves in Southern California during 2001–2004, conclude that “under current conditions. . .the ability to speak Spanish very well can be expected to disappear sometime between the second and third generation for all Latin American groups in Southern California.” They also found that “the average Asian language can be expected to die out at or near the second generation” (ibid). A number of critical scholars (e.g., Ricento 2005a; Wiley 1998), using historical and discourse analytic research methods, have shown that the ideology of English monolingualism in the USA was largely achieved during the Americanization movement in the period prior to and immediately following the US entry in World War I.

The third ideology is the “standard language ideology,” which elevates a particular variety of a named language spoken by the dominant social group to a (H)igh status while diminishing other varieties to a (L)ow status (Ferguson 1972). This variety is claimed (by its speakers) to be more “logical,” “efficient,” and “correct” than most other varieties. The “standard” variety tends to gain legitimacy through the publication of dictionaries, style sheets, and grammar books which provide usage guides and “correct” spelling and pronunciation (however, reflecting the fact that no language can be completely standardized, variations for both spelling and pronunciation are included, thousands of new words are not represented, the meaning of well-attested words often shifts, and changes in spelling, grammar, and pronunciation render dictionaries less authoritative than language purists would care to admit). Those who speak other varieties, often referred to as “bad [English/Spanish/French, etc.]” or “vulgar,” “uncivilized,” “illogical,” and so on, often ascribed other defects in intelligence, behavior, and morality. Speakers of these “nonstandard” varieties may suffer discrimination and obstacles in education and employment opportunities simply because they do not command the prestige (standard) variety. The “cure” for speakers of “nonstandard” varieties, according to mainstream educators, is to replace the “bad” language variety with the “good” (“standard”) variety. While some individuals clearly do have opportunities and the desire to modify their language, those who do not are then blamed for their own failure to “assimilate” or become acculturated to the mainstream language variety. As Lippi-Green (2012) points out, communication is (at least) a two-way process, requiring goodwill on the part of both parties in a two-way communication. If a teacher (as seen in the research by Rist earlier), for example, prejudices a person’s intelligence and character based on the way they speak, the blame for “miscommunication” typically resides with the speaker society deems to be deficient. Thus, language minorities are often blamed for their educational failures because of the “shortcoming” of speaking a variety different from those of higher social and economic class (Dudley-Marling and Lucas

2009; Johnson 2014). The claims made by Lippi-Green and many other scholars in recent years are based on findings from sociolinguistic research, including attitudinal measures such as Likert, matched guise, and the semantic differential techniques, and ethnographic studies in multilingual communities (see Baker 2006, for discussion of methods used in assessing attitudes toward languages and those who speak them).

Another important contribution to research in language and ideology has come from scholars working in poststructuralist/postmodern paradigms (see Pennycook 2006 for a discussion of these two terms). While scholars from critical paradigms have tended to invoke categories such as race, class, and ethnicity as crucial in understanding the nature and effects of language policies and practices in educational contexts, scholars working in postmodern paradigms have expressed great skepticism about such categories. Rather, as Pennycook (2006, p. 63) notes, such “taken-for-granted categories . . . are seen as contingent, shifting, and produced in the particular, rather than having some prior ontological status.” This approach does not discount the fact that racialized and gendered categories are ascribed by others and even taken up by group members themselves and that such ascribed characteristics are implicitly or explicitly invoked in policies involving language status, use, or acquisition in educational and other contexts. Rather, postmodern research is concerned (among other things) primarily with the specific ways in which power is exercised and reflected in the discourses of powerful interests. Scholars working within a postmodern framework tend to be skeptical of research which posits particular pedagogical approaches (such as bilingual/mother tongue education) as inherently superior to other approaches, since such approaches can as easily be employed by some groups to maintain social control as can a policy of monolingual instruction (see, e.g., Pennycook 2000). Postmodern scholars in applied linguistics tend to question the validity and utility of sweeping grand narratives (such as those associated with linguistic imperialism (Phillipson 1992) because such narratives often tend to perpetuate the same ideologies and modernist discourse (e.g., nation-state, standard language, mother tongues, discrete ethnic/racial/gender categories, and so on) which have enabled the dominance and domination of European “imperial” countries in the first place (see Ricento 2012, for a critique of Phillipson). For researchers, the most important implication of this shift in theory is that structural analyses which, for example, tended to localize the causes of social inequality within institutions, social structures, or ideologies are viewed as being too deterministic in explaining educational failure among language minority populations. Instead, researchers working within postmodern approaches have adopted methodologies, such as critical discourse analysis (van Dijk 1993), which investigate the ways in which social structures are mediated through discourse and how individuals (re) create and respond to these discourses in their lived (performed) experiences as members of diverse communities with complex identities. Another approach to understanding the operation of discourse(s) in society is scale analysis (Blommaert 2007; Hult 2010) that “. . . focuses on how discursive processes operate within and across scales of space and time. . . to understand[ing] relationships between language policies and the social actions of individuals” (Hult 2010, p. 8). A methodology

(or more accurately, a meta-methodology) that attempts to integrate methodological tools from interactional sociolinguistics, ethnography of communication, and critical discourse analysis in order to account for relationships between individual social actions and circulating discourses across dimensions of social context is nexus analysis (Scollon and Scollon 2004). As Hult (2010) puts it: “The elements of nexus analysis provide a rough guide for following the trajectories of fractal discourses as they are taken across scales of TimeSpace in order to mediate the social actions of LPP processes” (p. 21).

---

## Work in Progress

The critical turn in linguistics and applied linguistics has placed in doubt many of the foundational concepts that have guided research in the language sciences since at least the advent of modern linguistics in the mid-nineteenth century. Perhaps, the most fundamental critique has been the questioning of the nature of language itself as a fixed, discrete code, with the corollary (within the Chomskyan framework) of the native speaker who possesses, in his or her brain, the “rules” necessary to produce and interpret an infinite number of sentences. Critics of the “autonomy of syntax” paradigm, such as Talbot Taylor (1997), have argued that rather than describing language as it is used, the Chomskyan model is actually a prescriptive model which reflects the more or less standard version of the written language. Thus, “correct” grammar as determined by the intuitions of linguists reflects the rules of usage and “grammaticality” of the written standard language of the educated classes, i.e., the language of the linguists and the language of social power and mobility. In second language contexts, the “native speaker fallacy” promulgated by Chomsky and his adherents has dominated research in second language acquisition, learning, and teaching for the last 50 years. The ideology of the construct “native speaker,” the possessor (owner) of the “correct” language, has elevated the standard varieties of written languages as the only legitimate language in schooling and public life, generally, whereas indigenized varieties of “world” languages (such as English and French) have often been viewed as inferior or inadequate in comparison. This ideology has helped to perpetuate the dominance of particular varieties of “standard” languages (such as British and North American English) while casting into doubt the abilities and qualifications of teachers in EFL settings where such varieties of the language are not spoken.

Critical scholars in applied linguistics and related areas have investigated the effects of the ideology of the “native speaker” along with several other ideologies on research and practice in various educational contexts. Researchers working in postmodern paradigms, while not disputing the benefits of such critical research, have nonetheless questioned basic assumptions that have informed such research. That is, received categories such as language, mother tongue, native speaker, and so on, these scholars argue, may help perpetuate some of the very problems and inequalities such research seeks to correct. For example, scholars within a postmodern paradigm have claimed that the very positing of language as a discrete,

rule-governed system by linguists and other social scientists is in itself an important result of the modernist project, which has privileged and helped promote the hegemony of Western languages, thought and tools of inquiry throughout the world. Terms such as “standard” and “nonstandard” already imply a normative hierarchical framework with regard to language(s) and language varieties. The term “native speaker” implies there are “nonnative” speakers, and both terms are rooted in the eighteenth-century European conceptions of the “nation,” a group of culturally similar people who speak a common language (whether or not this is actually the case as it very often is not). In this sense, the “nonnative” speaker is almost by definition a “foreigner,” an “outsider,” or someone who can never really fully belong to the “nation.”

Another term of art, “ethnicity,” needs to be critically examined as well. Glynn Williams (1992) argues that in American sociology, ethnicity became a dichotomized construct of the normative/standard group – a unitary citizenry speaking a common language (us) – and nonnormative/nonstandard groups, including those speaking other languages (them). This naturalizing of a sociological construct (ethnicity) informs the widely held popular view promoted by Western scholarship that “reasonable” (modern) people should naturally become part of the culture of the state (or the transnational world) and speak its language, whereas irrational (traditional) people will tend to cling to their ethnic language and culture.

Interesting work has been done to counteract the hegemony of Western ways of “knowing” the world. The articles in Canagarajah (2002) demonstrate how researchers can use local knowledge in diverse settings to understand other cultures in ways that avoid the pitfalls of normative “etic” research. Makoni and Pennycook (2006) argue that Western-based and Western-imposed ideas about language – what it is and how it is represented – help perpetuate imperialist/colonized mentalities in South Africa and in other countries in the developing world. Borrowing from the work of Michel Foucault (1991), Makoni and Pennycook use the term governmentality defined as an “array of technologies of government,” which can be analyzed in terms of the different strategies, techniques, and procedures by which programs of government are enacted (in Pennycook 2006, p. 64). Pennycook (2006, p. 65) explains that language governmentality is best understood in terms of “how decisions about languages and language forms across a diverse range of institutions (law, education, medicine, printing) and through a diverse range of instruments (books, regulations, exams, articles, corrections) regulate the language use, thought, and action of different people, groups, and organizations.” A consequence of a governmentality approach is the questioning of grand narratives, which offer totalizing views of the role and effects of languages, such as English, in killing other languages and in homogenizing world culture, and the related claim that languages need protection through regimes of language rights. Such totalizing views, labeled “preservationist” and “romanticist,” often assume an ineluctable connection between language and ethnicity (Pennycook 2006). Pennycook (2006, pp. 68–69) argues that while linguistic imperialism and language-rights discourses “operate from different epistemological and political assumptions . . . both operate from within theories of economy, the state, humanity, and politics that have their origins in the grand modernist project.”

Blommaert (2006, p. 249) provides a case study on the limitations of the state to enforce a particular totalizing ideology on a multilingual nation. The attempt by the Tanzanian socialist government to effectuate socialist ideological hegemony through the spread of Swahili failed because of the existence and role of English and local indigenous languages in social life, as well as the persistence of “impure” varieties of Swahili. Blommaert argues that language policy should be seen as a *niched* activity in which, for example, the role of certain actors (such as the state) is limited to specific domains, activities, and relationships, not general ones.

The work of these and many other scholars does not seek to downplay the negative effects of linguistic imperialism nor diminish the possible benefits of a language-rights approach in contexts in which cultures and the languages that express them are threatened; rather, it seeks to problematize assumed causal relations between actors, groups, and language policies which may be empirically unsubstantiated and complicit with the very ideologies and constructs they wish to defeat (see, for example, Canagarajah 2013; Wee 2011).

---

## Problems and Difficulties

While the facts and effects of Western imperialism are debated by scholars in applied linguistics and other social sciences, conflicts involving language in education continue unabated in many parts of the world. Romaine (2015) provides evidence that English medium of instruction programs in low-income countries where it is not the language of the home or community is detrimental to academic achievement and attainment of a high level of literacy in any language. However, there have also been some significant policy changes in at least some English-dominant countries, despite ongoing opposition from those who support “English-only” language policies in public education; in the USA, despite many years of restrictions on bilingual education programs in states that passed “English for the Children” initiatives mandating structured English immersion programs (California, Arizona, and Massachusetts), dual language bilingual education programs have grown in popularity. California became the first state to offer a “Seal of Biliteracy” on the high school diploma of graduates who could provide evidence of proficiency in another language, a distinction now available in other states including Texas, New York, Washington, and Illinois (Wright and Ricento *in press*). There has also been a growth in heritage language programs in K-12 schools and in higher education (Lee and Wright 2014). Yet, despite these positive changes, the number of students studying strategically important languages, such as Arabic, Urdu, Pashto, and Farsi, in the USA remains quite low. For example, based on the data on foreign language enrollments in US postsecondary institutions for fall 2002, compiled by the Modern Language Association, only 10,584 students were reported to be enrolled in Arabic language classes, representing 8% of the total foreign language enrollments. Research on attitudes toward the study of languages in addition to English in schools in the USA, generally, has tended to focus on the perceived economic and social benefits associated with learning and using particular foreign/second languages in

various contexts. Critical scholars, using techniques of discourse analysis and historical analysis (e.g., Ricento 2005b), have argued that immigrant languages in countries such as the USA have generally not survived into the third generation due to many factors, including social pressure for immigrants to assimilate fully to English and American cultural norms. In the European context, Francois Grin (2003) provides a model for evaluating competing language plans for protecting and promoting minority languages relying, in large part, on cost-effectiveness as a criterion for policy selection and design. This approach takes into account a range of variables relevant to language planning and decision-making and can be applied to diverse demographic and sociolinguistic contexts and settings.

Decisions about which language(s) should be used as the medium of instruction or offered as subjects in schools are often contentious and in a state of flux, reflecting changes in local, regional, national, and/or global political conditions. All these factors play a role in Malaysia, where Chinese-medium schools have come under pressure and where a public controversy erupted over a government decision to start teaching mathematics and science in English after 20 years in which they had been taught in Malay.

Another case involving controversies about medium of instruction is in the Republic of Slovakia in which the minority Hungarian population has resisted attempts by the Slovak majority to replace Hungarian mother tongue education with a Slovak-Hungarian bilingual program (Langman 2002). Each group is guided by particular ideologies about how the Slovak state should be constructed and the role of language in this process. This is an example in which the histories of various ethnolinguistic groups continue to influence their current aspirations and fears about their status, both within the Republic of Slovakia and also within an expanding European Union. Long memories and fears about absorption and assimilation (by the Hungarians) or about the emergence and realignment of a “Greater Hungary” in the region (by the Slovaks) have complicated prospects for a solution acceptable to all parties.

There have also been some notable successes in instantiating multilingual language ideologies, however. Egger and Lardschneider McLean (2001) report on a solution to the “standard” language problem with regard to Ladin in South Tyrol, Italy. Ladin is used primarily as a spoken language (although it is written), and attempts to standardize the many dialects of Ladin into an artificial, common variety have been resisted and perceived as a danger to the survival and vitality of the language. This suggests one way that the ideology of “standard language,” which privileges one particular variety of a language while downgrading other varieties deemed to be “nonstandard,” can be thwarted. Another example of how a minority language can be revitalized, despite lack of official governmental recognition, exists in the Basque region of France. The Basque language is not officially recognized or supported by the French state (although it does have co-official status with Spanish within the autonomous Basque community of Spain (Euskadi). In the 1960s, a small group of Basque parents in France organized a Basque language preschool. Out of this effort, an organization (called “Seaka,” meaning seed) began coordinating a few community-based Basque-language primary schools, using a model developed in Spain during the Franco era (Paulston and Heidemann 2006, p. 304). By the end of

the 1970s, enrollment had grown from 8 to over 400 students. By 1990, over a dozen schools were operating, serving 830 students. As the commitment of the Basque community became more widespread, by the year 2000, nearly 2,000 students were enrolled in two-dozen Basque-medium schools from preschool to the high school level.

Another relatively successful attempt to revitalize a threatened minority language concerns the Saami language in Norway. Since the early 1990s, the status of Saami in public schooling has improved dramatically, and it is recognized as a legitimate medium across the curriculum (Todal 2003). The new attitude toward Saami has come about through a combination of regional political mobilization and the work of international indigenous rights organizations, which helped facilitate “a new attitude towards conflict solving on the part of the [Norwegian] authorities” (p. 191).

---

## Future Directions

One of the most promising areas of research on language, education, and ideology is critical discourse analysis (CDA). The central goal of CDA is to provide “an account of intricate relationships between text, talk, social cognition, power, society and culture” (van Dijk 1993, p. 253). Research in CDA is especially concerned with uncovering the implicit arguments and meanings in texts which tend to marginalize nondominant groups, in part by selectively asserting certain attributes, e.g., physical characteristics, cultural beliefs, and behavioral characteristics, among others. Examples of research in CDA relevant to language policies in education are Santa Ana (2002) and Ricento (2005b). More recently, quantitative studies using large text corpora have been conducted allowing researchers to investigate the relative frequency and distribution of words and phrases in large numbers of texts (e.g., Biber et al. 2007; Biber and Conrad 2009). CDA research has depended, largely, on linguistic analyses of written and spoken texts, uncovering the often implicit meanings which may be different from the explicit claims made by politicians in speeches and legislation on topics such as immigration and affirmative action. CDA, however, has been criticized for this focus on textual analysis at the expense of a deeper and theoretically motivated analysis of society. Another criticism is that not enough attention has been paid to ideas and models developed in cognitive and evolutionary psychology, which could help explain why certain types of exclusionary behavior persist and why the language forms associated with such behavior are so powerful (Chilton 2005). Despite these (and other) criticisms, CDA offers great promise as a research approach in the analysis of the nature and effects of ideologies on language and education at all levels of society.

---

## Cross-References

- ▶ [Ethnography and Language Education](#)
- ▶ [Ethnography of Language Policy](#)

- ▶ [Investigating Language Education Policy](#)
- ▶ [Linguistic Ethnography](#)

---

## Related Articles in the Encyclopedia of Language and Education

- Francis M. Hult: [Discursive Approaches to Policy](#). In Volume: Discourse and Education
- Rebecca Rogers: [Critical Discourse Analysis in Education](#). In Volume: Discourse and Education

---

## References

- Baker, C. (2006). Psycho-sociological analysis in language policy. In T. Ricento (Ed.), *An introduction to language policy: Theory and method* (pp. 210–228). London: Blackwell.
- Bereiter, C., & Engelmann, S. (1966). *Teaching disadvantaged children in the pre-school*. Englewood Cliffs: Prentice-Hall.
- Bereiter, C., Engelman, S., Osborn, J., & Reidford, P. (1966). An academically oriented pre-school for culturally deprived children. In F. M. Hechinger (Ed.), *Pre-school education today*. New York: Doubleday.
- Bernstein, B. (1966). Elaborated and restricted codes: Their social origins and some consequences. In J. Gumperz & D. Hymes (Eds.), *The ethnography of communication, American Anthropologist*, 66 (6, part 2).
- Biber, D., & Conrad, S. (2009). *Register, genre, and style*. Cambridge: Cambridge University Press.
- Biber, D., Connor, U., & Upton, T. A. (2007). *Discourse on the move: Using corpus analysis to describe discourse structure*. Amsterdam: Benjamins.
- Blommaert, J. (2006). Language policy and national identity. In T. Ricento (Ed.), *An introduction to language policy: Theory and method* (pp. 238–254). London: Blackwell.
- Blommaert, J. (2007). Sociolinguistic scales. *Intercultural Pragmatics*, 4(1), 1–19.
- Bourdieu, P. (1991). *Language and symbolic power*. Oxford: Polity.
- Canagarajah, S. (Ed.). (2002). Celebrating local knowledge on language and education. *Journal of Language, Identity, and Education*, 1(4), 243–333.
- Canagarajah, S. (2013). *Translingual practice: Global Englishes and cosmopolitan relations*. New York: Routledge.
- Chilton, P. (2005). Missing links in mainstream CDA: Modules, blends and the critical instinct. In R. Wodak & P. Chilton (Eds.), *A new agenda in (critical) discourse analysis*. Amsterdam: John Benjamins.
- Corson, D. (1993). *Language, minority education, and gender: Linking social justice and power*. Clevedon: Multilingual Matters.
- Dudley-Marling, C., & Lucas, K. (2009). Pathologizing the language and culture of poor children. *Language Arts*, 86(5), 362–370.
- Egger, K., & Lardschneider McLean, M. (2001). Trilingual schools in the Ladin valleys of South Tyrol, Italy. In D. Christian & F. Genessee (Eds.), *Bilingual education* (pp. 57–67). Arlington: TESOL.
- Ferguson, C. A. (1972). *Language structure and language use*. Stanford: Stanford University Press.
- Foucault, M. (1972). *The archaeology of knowledge*. New York: Pantheon.
- Foucault, M. (1991). Governmentality. In G. Burchell, C. Gordon, & P. Miller (Eds.), *The Foucault effect: Studies in governmentality* (pp. 87–104). Hemel Hempstead: Harvester Wheatsheaf.
- Gramsci, A. (1988). In D. Forgacs (Ed.), *An Antonio Gramsci reader: Selected writings, 1916–1935*. New York: Schocken Books.



- Grin, F. (2003). *Language policy evaluation and the European charter for regional or minority languages*. London: Palgrave Macmillan.
- Habermas, J. (1975). *Legitimation crisis*. Boston: Beacon Press.
- Hult, F. (2010). Analysis of language policy discourses across the scales of space and time. *International Journal of the Sociology of Language*, 202, 7–24.
- Inglehart, R., & Woodward, M. (1992). Language conflicts and political community. In J. Crawford (Ed.), *Language loyalties: A source book on the official English controversy* (pp. 410–422). Chicago: University of Chicago Press.
- Jensen, A. (1969). How much can we boost IQ and scholastic achievement?. *Harvard Educational Review*, 39, 1–123.
- Johnson, E. (2014). (Re)categorizing language-minority literacies in restrictive educational contexts. *International Multilingual Research Journal*, 8(3), 167–188.
- Labov, W. (1972). *The logic of nonstandard English*, in *Language in the inner city: Studies in the Black English vernacular*. Philadelphia: University of Pennsylvania Press (Chapter 5).
- Langman, J. (2002). Mother-tongue education versus bilingual education: Shifting ideologies and policies in the Republic of Slovakia. *International Journal of the Sociology of Language*, 154, 47–64.
- Lee, J. S., & Wright, W. E. (2014). The rediscovery of heritage and community language education in the United States. *Review of Research in Education*, 38, 137–165.
- Lippi-Green, R. (2012). *English with an accent: Language, ideology, and discrimination in the United States* (2nd ed.). London: Routledge.
- Lo Bianco, J. (2004). Language planning as applied linguistics. In A. Davies & C. Elder (Eds.), *The handbook of applied linguistics* (pp. 738–762). London: Blackwell.
- Makoni, S., & Pennycook, A. (Eds.). (2006). *Disinventing and reconstituting languages*. Clevedon: Multilingual Matters.
- Matsui, M. (1995). Gender role perceptions of Japanese and Chinese female students in American universities. *Comparative Education Review*, 39, 356–378.
- McGregor, L. (Ed.). (1998). Gender issues in language teaching [special issue]. *The Language Teacher*, 22.
- Norton, B. (2000). *Identity and language learning: Gender, ethnicity and educational change*. London: Longman.
- Paulston, C. B., & Heidemann, K. (2006). Language policies and the education of linguistic minorities. In T. Ricento (Ed.), *An introduction to language policy: Theory and method* (pp. 292–310). London: Blackwell.
- Pennycook, A. (1994). *The cultural politics of English as an international language*. London: Longman.
- Pennycook, A. (2000). Language, ideology and hindsight: Lessons from colonial language policies. In T. Ricento (Ed.), *Ideology, politics and language policies: Focus on English* (pp. 49–65). Amsterdam: John Benjamins.
- Pennycook, A. (2006). Postmodernism in language policy. In T. Ricento (Ed.), *An introduction to language policy: Theory and method* (pp. 60–76). London: Blackwell.
- Phillipson, R. (1992). *Linguistic imperialism*. Oxford: Oxford University Press.
- Ricento, T. (2005a). Considerations of identity in L2 learning. In E. Hinkel (Ed.), *Handbook of research in second language learning and teaching*. Mahwah: Lawrence Erlbaum (pp. 895–911)
- Ricento, T. (2005b). Problems with the ‘language-as-resource’ discourse in the promotion of heritage languages in the U.S.A. *Journal of Sociolinguistics*, 9, 348–368.
- Ricento, T. (2012). Political economy and English as a ‘global’ language. *Critical Multilingualism Studies*, 1, 30–52.
- Ricento, T. (2015). Refugees in Canada: On the loss of social capital. In B. Spolsky, O. Inbar-Lourie, & M. Tannenbaum (Eds.), *Challenges for language education and policy: Making space for people* (pp. 135–147). New York: Routledge.

- Rist, R. (1970). Student social class and teacher expectations: The self-fulfilling prophecy in ghetto education. *Harvard Educational Review*, 40, 411–451.
- Romaine, S. (2015). Linguistic diversity and global English: The pushmi-pullyu of language policy and political economy. In T. Ricento (Ed.), *Language policy and political economy: English in a global context* (pp. 252–275). New York: Oxford University Press.
- Rumbaut, R. G., Massey, D. S., & Bean, F. D. (2006). Linguistic life expectancies: Immigrant language retention in Southern California. *Population and Development Review*, 32(3), 447–460.
- Santa Ana, O. (2002). *Brown tide rising: Metaphors of Latinos in contemporary American public discourse*. Austin: University of Texas Press.
- Scollon, R., & Scollon, S. W. (2004). *Nexus analysis: Discourse and the emerging internet*. London: Routledge.
- Taylor, T. (1997). *Theorizing language: Analysis, normativity, rhetoric, history*. Amsterdam: Pergamon.
- Todal, J. (2003). The Sámi school system in Norway and international cooperation. *Comparative Education*, 39, 185–192.
- Tollefson, J. (1991). *Planning language, planning inequality: Language policy in the community*. London: Longman.
- van Dijk, T. (1984). *Prejudice in discourse*. Amsterdam: John Benjamins.
- van Dijk, T. (1993). Principles of critical discourse analysis. *Discourse & Society*, 4, 249–283.
- Veltman, C. (1983). *Language shift in the United States*. Berlin: Mouton.
- Wee, L. (2011). *Language without rights*. Oxford: Oxford University Press.
- Wiley, T. (1998). The imposition of World War I era English-only policies and the fate of German in North America. In T. Ricento & B. Burnaby (Eds.), *Language and politics in the United States and Canada: Myths and realities* (pp. 211–241). Mahwah: Lawrence Erlbaum.
- Wiley, T., & Lukes, M. (1996). English-only and standard English ideologies in the U.S. *TESOL Quarterly*, 30, 511–535.
- Williams, G. (1992). *Sociolinguistics: A sociological critique*. London: Routledge.
- Wodak, R., & Reisigl, M. (2003). Discourse and racism. In D. Schiffrin, D. Tannen, & H. E. Hamilton (Eds.), *The handbook of discourse analysis* (pp. 372–397). Oxford: Blackwell.
- Woolard, K. A., & Schieffelin, B. (1994). Language ideology. *Annual Review of Anthropology*, 23, 55–82.
- Wright, W.E., & Ricento, T. (in press). Language policy and education in the United States. In T. McCarty (Ed.), *Language policy and political issues in education* (Vol. 1). In S. May (General Editor), *Encyclopedia of language and education* (3rd ed.). Dordrecht: Springer.

---

# Censuses and Large-Scale Surveys in Language Research

Jennifer Leeman

---

## Abstract

Although they typically include just one or two questions about language, censuses and large-scale government surveys are a rich source of data for examining patterns and trends in language knowledge and use. This chapter begins with a brief history of census taking, which dates back several millennia and which became a key administrative technology of modern nation-states and colonial projects. Motivations for the nineteenth century introduction of census questions about language knowledge and use are then discussed, with particular attention paid to methodological concerns regarding the focus and formulation of the questions. This chapter presents major contributions from three areas: (1) the field of survey methodology, (2) research on survey language questions, and (3) analyses of the ideological aspects of census language questions, and then provides information about additional large-scale surveys on language and education. The challenges of using census data in language research are then discussed, including the inconsistency of questions asked in different places, changes in the questions over time, and reliability and validity concerns regarding self-report data. The chapter concludes with a consideration of recent trends in survey methods and how these are likely to affect censuses and surveys about language.

---

## Keywords

Language policy • Ideologies of Language • Nationalism • Politics of Language

---

J. Leeman (✉)

Department of Modern and Classical Languages, George Mason University, Fairfax, VA, USA

e-mail: [jleeman@gmu.edu](mailto:jleeman@gmu.edu)

## Contents

Introduction .....	84
Early Developments .....	85
Major Contributions .....	86
Survey Methodology .....	86
Surveying Language .....	87
The Ideologies and Politics of Censuses .....	88
Work in Progress .....	90
Problems and Difficulties .....	92
Future Directions .....	93
Cross-References .....	95
Related Articles in the Encyclopedia of Language and Education .....	95
References .....	95

---

## Introduction

Surveys are a valuable resource for language and education research as they can include questions on a wide range of topics and they can be administered via numerous formats and modes including paper or online questionnaires as well as telephone or in-person interviews. Although questionnaires used to collect data about individuals – to identify a child’s home language background in order to make educational decisions about that child, for example – are also sometimes referred to as “surveys,” survey methodologists generally adopt a narrower definition that focuses on the collection of data to be used in the aggregate.

Generally speaking, there are two broad categories of surveys: those that measure opinions and attitudes, and those that quantify presumably objective information. In the realm of language and education, examples of the former category include public opinion polls about official language policies, on whether bilingual education should be provided or regarding the value of bilingualism. Examples of the latter category include surveys and censuses that gather information on the linguistic characteristics, language use, or educational attainment of a given population.

Surveys can be conducted at a wide range of scales, such as in a single classroom, in a given city or region, or at the national or international level, and they can be carried out by a wide range of public and private actors, including educators, researchers, policy makers, and marketing professionals. In most cases, surveys are administered to a sample drawn from a larger population in order to describe or analyze that population based on patterns observed in the sample. Nonetheless, censuses are also generally considered to be surveys even though they often seek to count an entire population directly, rather than make an estimate based on a subset or sample. The present chapter focuses on language questions on censuses and other large-scale surveys, which constitute one source of data for examining patterns and trends in language knowledge and use, but many of the issues discussed here, such as the formulation of language questions, are also relevant for researchers designing their own smaller scale surveys.

## Early Developments

The history of surveys dates back several millennia to the agricultural and population censuses of ancient Babylonia, ancient China, ancient Egypt, and the Roman Empire. Other notable early censuses include the *Domesday Book*, a compilation of data on every manor and village in England, which began in the year 1086, and the recording of local, regional, and empire-wide statistics on *quipus* (a recording system comprised of knots on colored ropes) during the Inca Empire (Bethlehem 2009). Early censuses generally consisted of an enumeration of the population for purposes of taxation or to determine military obligations, but other data, such as marital status and occupation, number of livestock, or property characteristics, sometimes also were collected.

While the history of census taking can be traced back thousands of years, the development of modern nation-states increased their use, as official statistics were needed for efficient centralized administration. So too, the rise of democratic governments led to the establishment of periodic censuses in order to gather data for the determining electoral districts and representation (Bethlehem 2009). Surveys have also long been used to investigate social problems. For example, beginning in 1834, the Manchester Statistical Society utilized sophisticated surveys and standardized data collection protocols to examine working conditions and education, and at the turn of the nineteenth century, Charles Booth conducted household interviews in order to produce his *Life and Labour of the People in London* (Groves et al. 2013; Wright and Marsden 2010).

In addition to these administrative uses, censuses also played a key ideological role, as both nationalist and colonial projects required the delineation of boundaries between nations and peoples (Anderson 1991; Makoni and Pennycook 2005). In order to identify colonial Others and to institutionalize collective and national identities, censuses increasingly classified populations according to social and cultural criteria, including race, ethnicity, and language (Kertzer and Arel 2002). For example, censuses in the USA, the first of which was conducted in 1790, have always classified residents by race or “color,” even when such statistics did not serve any specific legislative or administrative purpose (Nobles 2000). In 1846, Belgium became the first nation to introduce a census language question; Prussia and Switzerland did so in the 1850s (Arel 2002).

The modern interest in censuses is reflected both in the increased census-taking activity and in the establishment of the International Statistical Congress, which met in Europe approximately every 3 years during the second half of the nineteenth century (Kertzer and Arel 2002). Participants discussed best practices and sought to promote consistency across nations in the way particular constructs were measured, in order to facilitate data sharing and international comparisons. For example, the question of who should be included in censuses was discussed, and a recommendation to count all residents (not just citizens) was issued and became standard practice (Kertzer and Arel 2002). After the turn of the nineteenth century, the use of censuses

spread widely, and most nations now administer them regularly. Further, modern bureaucracies have required more and more kinds of data, resulting in an increase in census questions, as well as in the widespread use of surveys to collect data on employment and immunizations (Groves et al. 2013).

One topic debated at the International Statistical Congress sessions held in Vienna (1857), London (1860), and St. Petersburg (1872) was how best to quantify cultural or ethnic nationality, as opposed to political nationality. Participants were concerned that respondents who did not think of themselves in terms of collective identities would have trouble answering direct questions about ethnicity or cultural nationality and they agreed that language could serve as a more readily accessible proxy (Arel 2002). Nonetheless, there was no universal recommendation to inquire about language nor any consensus regarding which aspect of language – such as mother tongue, language use, or language knowledge – should be asked about. Thus, countries that inquired about language on their censuses did not always formulate the questions in the same way or focus on the same aspect (or any specific aspect) of language knowledge or use. For example, the 1891 census of Wales included a column in which enumerators were to specify whether individuals were English speaking, Welsh speaking, spoke both English and Welsh, or spoke other languages (Pryce and Williams 1988), whereas the 1901 Canadian census schedules had columns for enumerators to record individuals' ability to speak English and French, as well as a column in which to record mother tongue (Library and Archives Canada n.d.).

---

## Major Contributions

### Survey Methodology

Numerous disciplines, including anthropology, demography, linguistics, political science, psychology sociology, and statistics, have made significant contributions to the field of survey methodology in general and to the development of surveys on language and education in particular. Although sampling had been employed as early as the seventeenth century, when John Graunt utilized averages of births and deaths from a subset of parishes to calculate estimates for the entire population of London, probability theory was refined and applied to social phenomena in the nineteenth century (Bethlehem 2009; Wright and Marsden 2010). In the early twentieth century, sampling theory came into its own as statisticians recognized that the representativeness of samples, which takes into account the probability of an individual being included in the survey, is more important than sample size for making reliable inferences about entire populations (Groves et al. 2013; Wright and Marsden 2010). Since that time, advances in computer technology, geographic information systems, software engineering, data processing, and storage capacity have allowed for increasingly sophisticated sampling and analysis. So too, computer-assisted survey administration has made it possible to design complex surveys with intricate “skip patterns” and multiple pathways through a survey, depending on responses to early questions. In places where there is widespread access to

telephones and/or the Internet, such telecommunications technologies permit faster and more economical survey administration.

In the early twentieth century, journalists became increasingly interested in quantifying public support for political candidates and positions, while market researchers sought to measure consumer attitudes and preferences. Psychologists developed new survey methods for assessing subjective constructs such as attitudes, satisfaction, and agreement with specific policy statements. Particularly well-known is the work of Rensis Likert, who, in his 1932 Ph.D. dissertation, developed a method for combining scores on questions that asked respondents to express their level of agreement with a statement on a scale, typically containing five distinct values (Edmondson 2005). The growing interest in measuring subjective attributes led to a greater emphasis on standardization in question wording and data collection, as subjective questions were seen as more easily impacted than factual questions by slight changes in how they were asked (Groves et al. 2013).

Beginning in the 1970s, cognitive psychology has been used to systematically analyze how respondents interpret and respond to survey questions, which in turn has revolutionized how questions are developed and tested (Wright and Marsden 2010). Survey developers are now advised not just to pay careful attention to question wording in order to improve comprehensibility and reduce ambiguity but also to carry out cognitive testing with a range of individuals and probe them on their interpretation of questions and response options, as well as their reasons for responding as they do. Since the 1970s, the expansion of public and private surveys and the concomitant solidification of the field of survey methodology have led to the production of a large body of research on these issues, as well as on a wide range of other topics, such as the impact of mode (e.g., paper questionnaire vs. in-person surveys), interviewer characteristics (such as gender, ethnicity or race), and survey length on data quality and response rates.

## Surveying Language

In addition to advances in survey methodology, which are useful for surveys on all kinds of topics, there has also been significant research specifically on census questions about language. Such research includes classifications and analyses of the various ways that censuses and large-scale surveys ask about language, explorations of the ideological and political motivations for the data produced by different questions, and considerations of the advantages and disadvantages of different question formulations for specific policy or research objectives. Clearly these analyses can guide researchers designing their own surveys on language knowledge or use. However, it is also imperative that researchers and policy makers take such issues into account when using data from censuses and large-scale surveys for sociolinguistic research or as the basis for linguistic and educational policy decisions.

Lieberson's (1966, 1980) seminal work on the use of census language questions for macro-sociolinguistic research stresses the value of census language data for

identifying areas where speakers of particular languages are concentrated, providing a general sense of the linguistic situation of the research context and offering historical perspective on patterns of language use or knowledge. Lieberson identifies three principal foci of language questions: (1) mother tongue, (2) language usually used by the individual or in the home, and (3) languages that the individual knows, although he points out that even within these categories, different censuses often formulate questions in different ways. For example, the 1890 Hungarian census defined mother tongue as “that language which you recognize as your own and which you enjoy most speaking,” whereas the Prussian census defined it as “that language in which one is most fluent from childhood on and in which one thinks and also prays” (Arel 2002).

Although also Lieberson expresses some apprehension regarding “intentional distortion by the respondent or government body” (1966, p. 269), his primary area of concern about the census data is the lack of reliability of self-report language ability questions. In particular, he notes that such questions tend to lack an operational definition of language knowledge and often consist of binary yes/no questions. To address this, Lieberson proposes two possible approaches: either including some kind of objective measure, which would include requiring respondents to demonstrate (rather than describe) their linguistic competence, or greatly expanding the number of language questions to include inquiries about speaking, understanding, reading and writing abilities, mother tongue, language preference, and the most commonly used language in specific domains or social contexts such as at home, at work, and in religious activities. While it may not be feasible for a census or large-scale multi-topic survey to adopt either of his proposals, they nonetheless constitute a guidepost for language-focused surveys as well as food for thought regarding the range of questions that could be asked but rarely are.

Building on Lieberson’s work, deVries (1985) discusses how the three different types of questions are designed to measure different constructs: whereas mother tongue questions are intended to capture inherited characteristics, inquiries about languages used emphasize current use. Recognizing that the principal reason that governments include language questions on censuses is to inform the design and implementation of language policies, deVries focuses on the different kinds of data that each type of question produces, paying particular attention to the Canadian census. The Canadian census is unusual among the world’s censuses in its simultaneous use of language questions in all three categories (Arel 2002; Christopher 2010), a fact that reflects the salience of language in Canadian social and political life. DeVries also demonstrates how the inclusion of multiple language questions allows for calculated variables that can be used to quantify language maintenance and shift.

## **The Ideologies and Politics of Censuses**

The late twentieth century surge of academic attention to ethnic and national identities has led to increased scrutiny of the role of states and public institutions in the reproduction of those identities (Kertzer and Arel 2002). At the same time,



growing interest in the politics and ideologies of language has led researchers to examine how censuses and census taking reflect particular understandings of the relationship of language to various identity categories that can be deployed to advance particular political agendas (Arel 2002; Urla 1993). As Urla states, census statistics “operate simultaneously as technologies of scientific knowledge, of government administration, and of symbolic representation” (1993, p. 819).

One way that census language questions and politics are intertwined is that census data serve as key evidence for legitimating nationalist claims; when language is perceived as a central indicator of “cultural nations,” statistics offer both official recognition of minority identities and numerical documentation of their presence (Arel 2002). Of the three categories of language questions, Arel suggests that debates about mother tongue and language of use questions are the most politically charged, given that decisions about the language(s) to be used by the state (including in public education) often depend on the relative proportion of speakers of different languages. Still, in places like the USA, where immigrants are disparaged for their supposed failure to learn the national language, language proficiency statistics are also deployed in policy debates (Leeman 2004, 2013).

According to Arel (2002), nationalists tend to favor what he calls “backward-looking questions,” which seek to capture individuals’ linguistic “essence,” regardless of whether they actually speak that language or have undergone shift to a higher status or majority language. Not only are mother tongue questions more oriented toward a pre-assimilation past than are current-use questions, but different formulations and definitions of mother tongue also differ in their orientation. For example, defining mother tongue as the household language when an individual was a child, as the 1970 US census did, is more backward-looking than a definition including or emphasizing current preferences and use, such as the examples from the Hungarian and Prussian examples cited earlier.

Like the ways that questions about language are formulated, the ways that respondents answer them also can be strategic or influenced by language politics. For example, when a 1932 Belgian law established that the officially monolingual Flemish districts outside of Brussels would be attached to bilingual Brussels if the census documented a high proportion of French speakers, many people of Flemish descent chose to identify themselves as speakers of French on the census because that was the language in which they wanted their children to be educated (Arel 2002). While language status and/or prejudice can operate below the level of consciousness, there have also been explicit campaigns to convince people to respond to census questions in particular ways. For example, in the first part of the twentieth century, Czech and German associations in Austrian Teschen mobilized for people to report the “right” language on the census (Kertzer and Arel 2002). Ideology also affects the way data is tabulated and presented; according to Cardinal (2005), Statistics Canada’s reports of language statistics promote a particular view of a bilingual nation that obscures language shift to English among Francophones and immigrants.

It should be noted that sociocultural context is crucial to understanding the sociopolitical meanings and implications of including census language questions

or of formulating them in particular ways. For example, while European and Francophone Canadian nationalist movements have utilized mother tongue questions to bolster demands for minority language rights, the early twentieth century collection of such data served a very different social purpose in the USA. Specifically, in an era of nativist mobilization and public anxiety regarding the racial make-up of recent immigrants, the US Congress mandated the addition of a mother tongue question to the 1910 census (Leeman 2004). The question was asked of foreign-born residents as well as US-born residents with foreign-born parents, with the US-born children classified according to their parents' mother tongue, making this definition even more backward-looking than questions about childhood use. Rather than being used to recognize minority rights, the US census's early twentieth-century mother tongue question was used to quantify racial Otherness.

Recent research stresses the bidirectionality of ideologies and censuses (e.g., Goldschneider 2002; Kertzer and Arel 2002; Leeman 2004, 2013; Urla 1993). In other words, it is not just that the choice of questions reflects particular ways of understanding language and identity or is shaped by particular policy goals. Instead, the practices of quantification are "constitutive of social reality and the social self" (Urla 1993, p. 820), and the ways in which the questions are asked and the categories defined "convey a 'theory' of groupness" or particular constructions of social identities and collectivities (Goldschneider 2002, p. 72). For example, Urla's (1993) pioneering analysis of the Basque government's census shows how inclusion of three response options for reporting Basque knowledge reconfigured the understanding of Basque identity from a binary (i.e., either Basque or not Basque) to a continuum with different degrees of "Basqueness," while the inclusion of question about Basque literacy reframed Basque language by linking it to education and modernity. Similarly, Leeman (2004) argues that the US Census Bureau's lack of questions on proficiency in non-English languages, the juxtaposition of the question about "languages other than English" being spoken in the home with a question about English-speaking ability, and the treatment of language in supplemental materials portray the nation as monolingual in English and represent other languages as a threat. At the same time, the discursive linking of "Hispanic origin" to Spanish reinforces the stereotype of US Latinx as unwilling to speak English (Leeman 2013).

---

## Work in Progress

Most modern nations conduct periodic censuses, and many of them include one or more questions about language, although this is certainly not universal. The kinds of questions included vary from place to place (see Christopher 2010 for a comparison of the language questions on the Commonwealth country censuses and Morning 2008 for ethnic classification systems, including language, around the world). A lack of language questions on censuses is sometimes the result of political or ideological conflict linked to language, as in the case of Belgium, which after defining districts as either monolingual or bilingual eliminated the language question and "froze" the status quo indefinitely (Arel 2002). Other reasons for the omission of language

questions include the desire to avoid controversy and resistance to the census, as in the case of a recent Afghani census (Graham-Harrison 2013), and the lesser historical salience of language than race in public discourse and policy, as in the USA (Leeman 2004).

Many national statistical agencies carry out various large sample-based surveys in addition to a periodic census. These surveys generally include more questions than the census, and thus even countries that do not ask about language on the census itself may nonetheless produce official language statistics based on survey data. For example, although the US census no longer contains any language questions, the US Census Bureau's American Community Survey (ACS) does. Household surveys that are carried out on a continual rolling basis, like the ACS, allow for the production and dissemination of updated statistics annually, rather than only in census years. Countries that have language questions on the census sometimes include additional questions on other surveys, such as the case of the Canadian National Household Survey (NHS), which inquires about knowledge of unofficial languages and languages spoken at work, in addition to the census questions on mother tongue, official language knowledge, and home language use.

In addition to national statistical agencies, other governmental and public institutions also carry out censuses and language surveys. For example, many Latin American countries' ministries of culture, social development, or indigenous affairs conduct surveys that include questions about indigenous language use. In Spain, the autonomous regions have their own statistical agencies, and these sometimes conduct or commission surveys about language use, as in the Basque case discussed earlier. Numerous nonprofit and research organizations also conduct large-scale surveys. One such example is Pew Research's Hispanic Trends Project, which not only carries out analyses of the US Census Bureau's data related to US Latinxs but also conducts their own surveys, some of which include multiple questions about language proficiency and use as well as opinions regarding the importance of English and Spanish (e.g., Taylor et al. 2012). The European Commission's (EC) Eurobarometer collects and publishes survey data about the language knowledge of EC residents, foreign language enrollments, and public opinion regarding language-related issues. Questions related to language policy or attitudes toward multilingualism and speakers of minority languages sometimes are also included in public polls conducted by private survey organizations and news media such as Gallup, BBC, and the New York Times. For example, recent opinion polls in the USA have asked whether immigrants to the USA are making enough effort to learn English and whether English should be the official language.

It is less common for censuses and surveys to collect data on literacy and educational attainment than on language, and the measurement of these constructs has received far less scholarly and political attention (but see Wagner 1990 for an overview and recommendations). UNESCO's Institute of Statistics compiles such data from over 200 countries and makes the data available for free on their website. Other sources of data related to language include media associations, such as the Pan Africa Media Research Organization (PAMRO) and the South African Advertising Research Foundation (SAARF). SAARF conducts an annual survey and produces

statistics on secondary home language and the number and composition of bilingual homes (Deumert 2010).

---

## Problems and Difficulties

The most obvious challenge for using census and survey data for language research is the fact that not all censuses include language questions or include just a few. Moreover, such questions generally are designed to collect data tied to very specific language policies, and thus are unlikely to coincide exactly with the researcher's goals. For example, censuses and large-scale public surveys very rarely collect information about language use in different domains or with different interlocutors (such as at work or school or between siblings), and they generally do not do a good job of collecting data about multiple languages spoken in a single domain or about individuals who have more than one mother tongue (see the Swiss Federal Statistical Office's Language, Religion and Culture Survey for an exception on both counts). Moreover, the rigidity of survey questions makes it difficult to elicit nuanced information about speakers' perspectives, language knowledge, and language use for which qualitative methods may be better suited.

There are also difficulties inherent to self-report data: respondents may not interpret questions as intended by the survey designer, or there may be variation among respondents in their interpretation of what it means to know a language or in the criteria they use to assess language knowledge and use. So too, as discussed above, survey responses can be strategic or linked to language status, social desirability, or fears of discrimination (Arel 2002; deVries 1985; Kertzer and Arel 2002; Lieberson 1966). Moreover, knowledge of a language should not be taken to mean that an individual actually uses the language in question; thus, survey statistics can give an overly optimistic sense of language vitality (Altuna and Urla 2013). In addition, languages are not objectively bounded entities (Makoni and Pennycook 2005), and speakers use a multiplicity of terms to label their linguistic practices. Thus, classification and labeling of languages in census statistics may not reflect the understandings or lived experience of speakers.

In addition, the high degree of variation regarding which questions are asked and how they are formulated impedes cross-national analyses. Even within the same context, questions are sometimes changed from census to census, impacting the data and complicating historical comparisons. The language questions on the US census are notorious in this regard; before 1980, the same questions were rarely included on more than two consecutive census surveys. Further, not only did the focus and formulation of the language questions change, sometimes inquiring about knowledge of English, other times asking about mother tongue or language spoken at home, but in some years the questions were asked of all people and in others, only the foreign-born or those who reported speaking a language other than English in the home. Even small changes can have an impact on data collected and thus on studies of language maintenance and assimilation. For example, beginning in 1901, the Canadian census defined mother tongue as the first language that an individual

learned and still spoke, but in 1941, the definition was modified making it sufficient to understand, rather than speak, the language first learned (deVries 1985). This change made it easier to track linguistic assimilation within the lifetime of minority language speakers (but still did not capture intergenerational language loss).

Other difficulties are related to timeliness, survey coverage, and representativeness. While censuses are designed to offer full coverage of entire populations, they are generally not conducted more than every 5 years (such as in the case of Canada) and often are even less frequent. Further, data compilation and publication take time, which means that up-to-date statistics are not always readily available. Sample-based surveys are typically conducted on a shorter cycle, but they may be less reliable for small area comparisons or languages spoken by relatively few speakers (Deumert 2010). In addition, surveys may have higher rates of nonresponse than censuses, and the often lower response rates among immigrants and individuals who do not speak the national language can introduce nonresponse bias (Groves et al. 2013). In addition to their impact on the distribution of material resources and political power, undercounts and nonresponse bias can also negatively affect census-based language research. However, when censuses and surveys are conducted in multiple languages, there may be crosslinguistic and cross-cultural differences in the constructs being surveyed, making it difficult to translate questions or develop equivalent surveys (Harkness et al. 2003).

---

## Future Directions

Several sometimes contradictory trends affecting all kinds of surveys and censuses are also likely to have an impact on census- and survey-based language statistics. These trends include the greater difficulty of contacting potential respondents within a specific household or geographic area, as a result of the shift from landlines to cellular telephones, and increased mobility (Krosnick et al. 2015). So too, residents of many developed countries are increasingly concerned about privacy and may be less willing to share their personal information, making it more difficult, and thus more costly, to conduct surveys (Groves 2011; Krosnick et al. 2015). At the same time, however, technological advances have increased access to telephones, and have made it possible to conduct surveys and censuses via the Internet. And while individuals may be growing wary of responding to surveys, they are simultaneously sharing increasing amounts of information about themselves on social media. More and more public and private entities are tracking, storing, and analyzing the “organic data” produced by activities outside the realm of survey taking, such as visiting websites or calling help lines (Groves 2011), and this type of data (such as the relative frequency of languages used in a specific context, such as in calls to help lines or on Twitter) can be used to supplement data collected directly from surveys. Statistical agencies have begun to use “meta data,” such as information about response rates and preferred modes in different areas and across demographic groups, in order to plan more effective contact strategies and optimize data collection operations.

Another recent trend that is likely to continue is for statistical agencies to use administrative records to supplement and/or evaluate the data collected via surveys (Lane 2010). For example, information from tax returns, hospital admittances, pensions, and public services can be linked to census records in order to complete partial records or to identify patterns of census undercounts and nonresponse (Krosnick et al. 2015; Wright and Marsden 2010). Advantages of this approach are that it can be more cost-effective as well as less burdensome for respondents. Potential drawbacks, particularly for language and ethnicity data, are that the administrative data sources may be less reliable than surveys as a result of differences in data collection procedures or in the formulation of questions and response options. While in many countries, the use of administrative records is seen as a new development and is used primarily for research and planning purposes or as supplement to a questionnaire-based census, the governments of Denmark, Finland, and Norway all conducted register-based censuses as early as the tenth century (Myrskylä 1991).

Recent years have seen an increasing interest in geography in both survey methodology and language research. Geographic information systems (GIS) technology could be utilized in census and survey data collection to record the specific location of responses, and this information could then be analyzed to produce statistics for geographic areas delimited by researchers on the fly, rather than in census tracts defined a priori, or to map areas where, for example, specific languages are spoken. Linguistic landscape research, a relatively new methodology, involves the observation of material manifestations of language in the built environment (Landry and Bourhis 1997; Shohamy and Gorter 2008). These studies often take a quantitative approach, focusing on the relative frequency or status of different languages within a multilingual area, and thus some linguistic landscape methodology could be considered a type of survey.

Another innovative methodology that involves the quantification of language use in a specific area was developed for the Basque Street Survey (Altuna and Urla 2013). In contrast with linguistic landscape's focus on signage and the built environment, the Street Survey quantifies spoken language use. Survey-takers walk along a preestablished route, silently listening to conversations taking place in public spaces and identifying the language(s) in which they occur. They do not interact with the people they encounter or ask them any questions; instead, they keep a tally of the languages they hear, as well as some social characteristics of the speakers. Because it relies on actual observation, rather than self-reports, the Street Survey method may give a better sense of the public use of minority languages than traditional censuses and surveys with questions about linguistic knowledge or mother tongue do.

One final area likely to see continued expansion and innovation is the administration of surveys in multiple languages. With increased awareness of multilingualism has come greater recognition of the importance of making surveys and censuses accessible for respondents who do not speak the national language(s). Such individuals often have higher rates of nonresponse and thus may not be adequately represented. The lack of data from such individuals obviously can have a particularly big impact on statistics about language knowledge and use. In the last few decades,

interest in how best to conduct multilingual surveys has increased, and there has been a blossoming of research in this regard (e.g., Behling and Law 2000; Harkness et al. 2003; Pan et al. 2014). In addition to exploring translation procedures and approaches, such as direct translation or crosslinguistic and cross-cultural adaptation, researchers have sought to develop effective methods for testing survey instruments and materials, as well as for encouraging participation among minority linguistic and cultural groups.

Although researchers are increasingly turning to ethnographic and other qualitative methods, studies employing such methods generally are limited in size and scope. In contrast, censuses and large-scale surveys produce data sets covering vast geographic areas and including large numbers of speakers, and they are typically available for public use. In cases where the same or similar questions have been asked over multiple censuses, such data sets can span multiple centuries, offering researchers a unique resource for historical as well as geographic comparisons and analyses. As long as scholars are aware of the limitations of survey questions and responses, as well as of the ideological underpinnings and implications of language questions and statistics, censuses and surveys will remain an important source of data for language research.

---

## Cross-References

- ▶ [Ethnography and Language Education](#)
- ▶ [Investigating Language Education Policy](#)
- ▶ [Researching Historical Perspectives on Language, Education, and Ideology](#)
- ▶ [Researching Language Loss and Revitalization](#)
- ▶ [Second Language Acquisition Research Methods](#)

---

## Related Articles in the Encyclopedia of Language and Education

- Luis E. Poza: [Assessing English Language Proficiency in the United States](#). In Volume: Language Testing and Assessment
- Kutlay Yağmur: [Multilingualism in Immigrant Communities](#). In Volume: Language Awareness and Multilingualism

---

## References

- Altuna, O., & Urla, J. (2013). The Basque street survey: Two decades of assessing language use in public spaces. *International Journal of the Sociology of Language*, 2013(224), 209–227.
- Anderson, B. (1991). *Imagined Communities: Reflections on the Origins and Spread of Nationalism*. London: Verso.
- Arel, D. (2002). Language categories in censuses: Backward-or forward-looking? In D. I. Kertzer & D. Arel (Eds.), *Census and identity: The politics of race, whtnicity, and language in national censuses* (pp. 92–120). Cambridge: Cambridge University Press.

- Behling, O., & Law, K. S. (2000). *Translating questionnaires and other research instruments: Problems and solutions*. Thousand Oaks: Sage.
- Bethlehem, J. (2009). *The rise of survey sampling* (Discussion paper No. 09015). The Hague: Statistics Netherlands. <http://www.cbs.nl/NR/rdonlyres/BD480FBC-24CF-42FA-9A0D-BBEC4F53090/0/200915x10pub.pdf>. Accessed 13 Dec 2014.
- Canada, Library and Archives. ND. "About the 1901 Census." <http://www.bac-lac.gc.ca/eng/census/1901/Pages/about-census.aspx#interpretation>. Accessed May 2 2013.
- Cardinal, L. (2005). The ideological limits of linguistic diversity in Canada. *Journal of Multilingual and Multicultural Development*, 26(6), 481–495.
- Christopher, A. J. (2010). Questions of language in the Commonwealth censuses. *Population, Space and Place*, 17, 534–549.
- Deumert, A. (2010). Tracking the demographics of (urban) language shift – An analysis of South African census data. *Journal of Multilingual and Multicultural Development*, 31(1), 13–35.
- deVries, J. (1985). Some methodological aspects of self-report questions on language and ethnicity. *Journal of Multilingual and Multicultural Development*, 6(5), 347–368.
- Edmondson, D. (2005). Likert scales: A history. *CHARM Proceedings: Conference on Historical Analysis and Research in Marketing* (Vol. 12, pp. 127–132).
- Graham-Harrison, E. (2013). Afghan census dodges questions of ethnicity and language. *The Guardian*. <http://www.theguardian.com/world/2013/jan/03/afghan-census-questions-of-ethnicity>. Accessed 13 Dec 2014.
- Goldschneider, C. (2002). Ethnic categorizations in censuses: Comparative observations from Israel, Canada, and the United States. In D. I. Kertzer & D. Arel (Eds.), *Census and identity: The politics of race, ethnicity, and language in national censuses* (pp. 71–91). Cambridge: Cambridge University Press.
- Groves, R. M. (2011). Three eras of survey research. *Public Opinion Quarterly*, 75(5), 861–871.
- Groves, R. M., Fowler, F. J., Couper, M. P., Lepkowski, J. M., Singer, E., & Tourangeau, R. (2013). *Survey methodology* (2nd ed.). Hoboken: Wiley.
- Harkness, J. A., Van de Vijver, F. J., & Johnson, T. P. (2003). Questionnaire design in comparative research. In J. A. Harkness, F. J. Van de Vijver, & P. P. Mohler (Eds.), *Cross-cultural survey methods* (pp. 19–34). Hoboken: Wiley.
- Kertzer, D. I., & Arel, D. (2002). Censuses, identity formation, and the struggle for political power. In D. I. Kertzer & D. Arel (Eds.), *Census and identity: The politics of race, ethnicity, and language in national censuses* (pp. 1–42). Cambridge: Cambridge University Press.
- Krosnick, J. A., Presser, S., Fealing, K. H., & Ruggles, S. (2015). *The future of survey research: Challenges and opportunities*. The National Science Foundation Advisory Committee for the Social, Behavioral and Economic Sciences Subcommittee on Advancing SBE Survey Research. [http://www.nsf.gov/sbe/AC\\_Materials/The\\_Future\\_of\\_Survey\\_Research.pdf](http://www.nsf.gov/sbe/AC_Materials/The_Future_of_Survey_Research.pdf). Accessed 10 Jul 2015.
- Landry, R., & Bourhis, R. Y. (1997). Linguistic landscape and ethnolinguistic vitality: An empirical study. *Journal of Language and Social Psychology*, 16, 23–49.
- Lane, J. (2010). Linking administrative and survey data. In P. V. Marsden & J. D. Wright (Eds.), *Handbook of survey research* (pp. 631–658). Bingley: Emerald Publishing Group.
- Leeman, J. (2004). Racializing language: A history of linguistic ideologies in the US Census. *Journal of Language and Politics*, 3, 507–534.
- Leeman, J. (2013). Categorizing Latinos in the history of the US Census: The official racialization of Spanish. In J. del Valle (Ed.), *A political history of Spanish: The making of a language* (pp. 305–323). Cambridge: Cambridge University Press.
- Lieberson, S. (1966). Language questions in censuses. *Sociological Inquiry*, 36(2), 262–279.
- Lieberson, S. (1980). Procedures for improving sociolinguistic surveys of language maintenance and language shift. *International Journal of the Sociology of Language*, 1980(25), 11–27.
- Makoni, S., & Pennycook, A. (2005). Disinventing and (re)constituting languages. *Critical Inquiry in Language Studies*, 2, 137–156.



- Morning, A. (2008). Ethnic classification in global perspective: A cross-national survey of the 2000 census round. *Population Research and Policy Review*, 27(2), 239–272.
- Myrskylä, P. (1991). Census by questionnaire – Census by registers and administrative records: The experience of Finland. *Journal of Official Statistics*, 7(4), 457–474.
- Nobles, M. (2000). *Shades of citizenship*. Stanford: Stanford University Press.
- Pan, Y., Leeman, J., Fond, M., & Goerman, P. (2014). *Multilingual survey design and fielding: Research perspectives from the US Census Bureau* (Statistical Research Division Study Series (Survey Methodology# 2014-01)). Washington, DC: U.S. Census Bureau. <https://www.census.gov/srd/papers/pdf/RSM2014-01.pdf>. Accessed 1 Dec 2014.
- Pryce, W., & Williams, C. H. (1988). Sources and methods in the study of language areas: A case study of Wales. In C. H. Williams (Ed.), *Language in geographic context* (pp. 167–237). Clevedon: Multilingual Matters.
- Shohamy, E., & Gorter, D. (2008). *Linguistic landscape: Expanding the scenery*. New York: Routledge.
- Taylor, P., Lopez, M. H., Martínez, J. H., & Velasco, G. (2012). *When labels don't fit: Hispanics and their views of identity*. Washington, DC: Pew Hispanic Center. <http://www.pewhispanic.org/2012/04/04/when-labels-dont-fit-hispanics-and-their-views-of-identity/>. Accessed 1 Dec 2014.
- Urla, J. (1993). Cultural politics in an age of statistics: Numbers, nations, and making of Basque identity. *American Ethnologist*, 20, 818–843.
- Wagner, D. A. (1990). Literacy assessment in the third world: An overview and proposed schema for survey use. *Comparative Education Review*, 34, 112–138.
- Wright, J. D., & Marsden, P. V. (2010). Survey research and social science: History, current practice, and future prospects. In P. V. Marsden & J. D. Wright (Eds.), *Handbook of survey research* (pp. 3–26). Bingley: Emerald Publishing Group.

---

# Researching Language Loss and Revitalization

Leena Huss

---

## Abstract

Language loss refers to a societal or individual loss in the use or in the ability to use a language, implying that another language is replacing it. Revitalization, in turn, is commonly understood as giving new life and vigor to a language that has been decreasing in use and is today a rapidly growing field of study. Both fields are highly multidisciplinary, drawing from linguistics, sociology, education, psychology, anthropology, political science, and other disciplines.

Since the 1990s, the research interest in endangered languages and consciousness of the need to contribute to their survival have grown among researchers, and numerous studies have been undertaken to present what has been done to curb language decline and to explain why some languages survive and others do not. Researchers have also tried to pinpoint the most relevant factors and the ways in which they interact. Still, to establish language revitalization more firmly as an independent field of study, more research and theorization are needed.

Many revitalization efforts are connected with ethnic revival movements as revitalization of the language is often seen as a crucial part of the overall ethnic revival. As a reaction to former forced assimilation and oppression, revitalization movements are often seen as ways to healing, redress, and empowerment. Therefore, a growing part of revitalization research is today being done by, or in close collaboration with, researchers and other members coming from the language communities themselves.

The chapter deals with research approaches in the field of language loss and revitalization, as well as challenges faced by scholars in this area.

---

L. Huss (✉)

The Hugo Valentin Centre, Uppsala University, Uppsala, Sweden

e-mail: [leena.huss@valentin.uu.se](mailto:leena.huss@valentin.uu.se)

---

**Keywords**

Assimilation • Language maintenance • Language shift • Language revitalization • Minority languages • Indigenous languages • The Sámi • The Kven • Tornedalians

**Contents**

Introduction .....	100
Early Developments and Major Contributions: Language Maintenance and Loss .....	101
Recent and Current Work: Language Revitalization .....	103
New Technologies and Language Revitalization .....	104
Problems and Difficulties .....	105
From “Neutral Research” to Advocacy .....	105
Collaboration Between Researchers and Communities .....	106
Defining “Success” Versus “Failure” in Language Revitalization .....	107
Future Challenges .....	107
Cross-References .....	109
Related Articles in the Encyclopedia of Language and Education .....	109
References .....	109

---

**Introduction**

Language loss refers to a societal or individual loss in the use or in the ability to use a language, implying that another language is replacing it. It is a very common phenomenon worldwide wherever languages are in contact. Language loss may be the result of subtractive bilingualism where a new language is learnt at the cost of the mother tongue (Lambert 1974), or it can be seen as the choice of a person who believes that ceasing to use a lower-status mother tongue will result in a better position in society or in higher prospects for the next generation. While this type of shift is often framed as “speaker’s choice,” we can question if this kind of choice is really “free” as it is strongly influenced by unequal power relations between languages and language groups (Dorian 1993).

The issue of language loss on a large scale, ultimately leading to the extinction of entire languages, was brought to a wider audience by Krauss (1992) more than two decades ago. According to his estimates, only 600 languages, that is, fewer than 10% of the languages spoken at that time, have good chances of surviving until the year 2100. One of the factors counteracting this trend is the corresponding effort at language revitalization. Efforts to bring back and strengthen small and threatened languages are being carried out today on all continents and under varying circumstances. This chapter provides discussion of previous and ongoing research on these issues as well as special questions and problems connected to this kind of research.

## Early Developments and Major Contributions: Language Maintenance and Loss

The field of language maintenance, loss, shift, and revitalization, on individual as well as societal levels, is highly interdisciplinary, drawing from linguistics, sociology, education, psychology, anthropology, political science, and other fields as well. During the first decades of study, until the 1950s and 1960s, a distinct emphasis was put on the language loss and shift aspect, largely neglecting its opposite: language maintenance and revitalization. Explicit revitalization movements such as they manifest themselves today – and research on such movements – were rare at that time. Up through the 1970s, researchers generally expected that minority languages would disappear in due course. This was regarded as a natural development, and people engaged in language maintenance efforts were often considered to be backward-looking romantics, political separatists, or unrealistic idealists (cf. Dorian 1998). Minority languages were seldom associated with economic or political power, and therefore they were considered as having no future. In immigrant communities, individuals were mainly perceived to be concerned with learning the majority language of the host country, while the original language often lost importance or was taken for granted by its speakers.

In his classic 1953 work, Weinreich laid the foundation for the scholarly study of language contact. He defined language shift as “the change from the habitual use of one language to that of another” (p. 68). While placing substantial focus on language contact and interference, Weinreich emphasized that language shift was rather motivated by language-external factors (e.g., assimilative pressure in society, negative attitudes) than by language-internal ones (e.g., grammatical or lexical features). An early study by Haugen (1953) focused on language loss and shift among Norwegian speakers in the USA. He described language use and linguistic attitudes prevailing among Norwegian–Americans in the homes and in religious life and the impact of English on Norwegian dialects. Haugen described a typical process of language shift as a series of stages all the way from monolingualism in the minority language through several bilingual stages to monolingualism in the majority language. While paying most attention to language shift, both Weinreich and Haugen also noted that there were forces and sentiments within minority communities that actively counteracted language shift.

A third scholar, Joshua Fishman, also had a strong impact in this field. His early work, *Language Loyalty in the United States* (1966), focused on the support among immigrant groups for language maintenance efforts. Ever since his early research, Fishman strived to describe and analyze the feelings and positions of linguistically and culturally endangered groups and from early on openly stood in favor of language maintenance efforts in research and in practice.

In the 1970s, sociologically oriented studies were carried out in various language communities. For instance, in Sweden, sociologist Jaakkola (1973) detailed the

strictly diglossic situation in Tornedalen in the 1960s, which was gradually paving the way to a language shift from the local Finnish variety to Swedish. Finnish was widely used by parents and elders, while the stigma attached to Tornedalen Finnish during almost a century of overt assimilation policies contributed to the common pattern of parents and grandparents speaking Swedish to their children and grandchildren. A well-known study on language death in a community was carried out by anthropologist Gal (1979), who showed how industrialization and urbanization contributed to language loss and shift among Hungarian speakers in Oberwart, Austria. When industrialization gained importance in Oberwart, the status of Hungarian declined as it was associated with peasant life. This led to a language shift from Hungarian to German, starting with the young generation. Another very influential work on societal language loss and death was linguist Dorian's (1981) study of a Scots Gaelic community in East Sutherland. Although a stigmatized, lower-prestige variety, Gaelic had a strong covert prestige among its speakers as the sign of group loyalty and fisherman identity. A large-scale language shift from Gaelic to English started when the importance of fishing declined and the segregation of the Gaelic-speaking population in society eased.

The studies by Jaakkola, Dorian, and Gal reflect the importance of the status of minority languages and the status of the groups speaking the language as perceived by the speakers themselves, as well as by the surrounding society. If maintaining a certain language is perceived as a sign of backwardness, poverty, or lack of formal education, shift to the dominant language is easily seen as the best option. For immigrant minorities, this kind of option, often resulting in the loss of the original language, may appear as the only way to go, especially in a situation where immigrant parents are not informed of the possibility of bilingualism. Wong Fillmore (1991) describes how young children in the USA speaking a minority language at home rapidly lost their first language when they started preschool in the USA. Learning the new language was seen as a first priority, and the younger the children were when coming into contact with English, the sooner they started losing their original language.

Through the 1980s and 1990s, language loss gained increased scholarly attention. Greater focus was given to the context in which language loss took place, and there was a shift to more detailed, descriptive, and anthropologically oriented studies. By interviewing groups of Sámi about their language choices and attitudes in their lives decade by decade, Aikio (1988) described in detail a case of Sámi language shift in Finland. Kulick (1992) studied the shift from the local language Taiap Mer to Tok Pisin in a New Guinea village where contact with Europeans changed local ideas about cultural identity and where parental language socialization patterns favored language shift. Norberg (1996) showed in her study on language choice and language attitudes in a low Sorbian village in the former Eastern Germany that a political change favoring cultural maintenance was not able to halt the continuing language shift to German. In these studies, as in several earlier ones, educational and employment opportunities, marriage patterns, or migration contributed to language shift, but views and attitudes toward one's own culture and their impact on language choice patterns in individual homes were given greater focus.

## Recent and Current Work: Language Revitalization

Many studies worldwide demonstrate the persistence of minority language speakers to maintain their languages against seemingly overwhelming odds. This kind of persistence, often regarded with surprise and even suspicion by some nonmembers, is a common feature in the context of community-based language maintenance and revitalization. Studies on language shift typically address situations where subordinate languages give way to more powerful and prestigious ones in a minority/majority constellation, while in language revitalization the process is slowed down or halted, and former subordinate languages rise in status and prestige.

Many revitalization efforts are connected with ethnic revival movements present in many parts of Europe and elsewhere since the 1960s but also with many nationalistic movements in the nineteenth and twentieth centuries. In the earlier cases, subordinate languages were not necessarily endangered at all, as for instance in the case of Norwegian in Norway and Finnish in Finland in the nineteenth century, but they were lacking in prestige and political power. In both the Norwegian and Finnish movements, the goal was to enhance the status of subordinate languages, while earlier nationalist movements typically promoted monolingualism and monoculturalism. Many modern ethnic revival movements promote multilingualism and the idea of several cultures living side by side (Huss and Lindgren 2011).

Ethnic revival has meant a new pride in formerly stigmatized languages and identities. In many parts of the world, ethnic movements start when the indigenous and minority languages are already seriously endangered, and the revitalization of the language is often seen as a crucial part of the overall ethnic revival. For instance, social scientist Stordahl (1996) observed in the Norwegian Sámi movement in the 1970s, that part of the movement was transforming the image of the Sámi language from that of a “dying language” to a “mother tongue” (p. 146).

Revitalization is commonly understood as giving new life and vigor to a language that has been steadily decreasing in use. It can be seen as a reversal of an ongoing language shift (cf. Fishman 1991), or it can be regarded as “positive language shift.” As King (2001) has observed, it is “possible to conceptualize language shift as positive or negative, referring to either the gain or loss of a group’s language, and thus encompassing all societal-level processes of language change” (p. 12). This view is especially useful when trying to describe the often contradictory tendencies present in many language contact situations. The revitalization process is hardly ever unidirectional; both assimilation and conscious revitalization within the minority group take place side by side (Huss and Lindgren 2011).

In the 1990s and early 2000s, there were more research on endangered languages and attention to the need to contribute to their survival, as well as discussion of critical issues (Crystal 2000; Grenoble and Whaley 1998; Hinton and Hale 2001; Skutnabb-Kangas 2000). Researchers and practitioners presented examples of what could be done and has been done in order to curb language decline. Across several areas of research, one of the driving questions was why some languages survive and others do not. Also, what were the relevant factors when explaining what affects

language maintenance and loss? Many attempts were made to pinpoint the most relevant factors and the ways in which they interacted (e.g., Crawford 2000; Crystal 2000; Edwards 1991; Fishman 1991; Stiles 1997).

A major advance in this direction was Fishman's work (1991), the first large-scale attempt to construct a theory of language revitalization. He presented a Graded Intergenerational Dislocation Scale (GIDS), a model assigning languages stages from one to eight, with the larger figures implying a more intensive disruption of the normal situation, a "more severe or fundamental threat to the prospects for the language to be handed on intergenerationally" (p. 87). Stage 8, the most threatened position, implies that the language is only used by some scattered, socially isolated old people, while at stage 1, cultural autonomy has been reached, with the language used in higher education and government as well as in the media nationwide. As can be seen in the name Fishman has given his typology, he regarded intergenerational transmission as the crucial factor in language shift reversal without which all other efforts are futile in the long run.

While acknowledging the importance of intergenerational transmission of minority languages, many researchers and practitioners engaged in grassroots revitalization saw education as a powerful agent of revitalization (e.g., McCarty 2002; Stiles 1997). The introduction of an endangered language in preschool and later education was, and often still is, expected to compensate for the typical lack of speakers among children and youth. Several studies around the world suggest, however, that revitalizing languages through schools is by no means an uncomplicated endeavor; even in circumstances where general attitudes toward the original language are becoming more and more favorable and the schools are officially expected to pay special attention to linguistic and cultural revitalization, the results often remain modest (Hornberger 2007; Huss et al. 2003; King 2001; Todal 2002). The schools might succeed in producing pupils with second language skills in the endangered language, but the problem remains how to go further and increase the number of pupils with high enough competence to maintain the language in the long run and, at best, to transmit it to their own children.

---

## **New Technologies and Language Revitalization**

Globalization is often regarded as a major threat to endangered languages, and one of its aspects, modern information and communication technologies, has also been viewed with suspicion by language revivalists. Today, however, new possibilities offered by technology for documentation and mass circulation of linguistic material, online language education, and other activities on behalf of endangered languages have become a strong focus of interest among those who have access to modern technology – all groups do not have it. The privileged practitioners as well as researchers working in endangered language communities are now in the process of creating databases, tools, and techniques for the advancement of their languages.

For endangered language communities and individuals interested in language revitalization, information and communication technologies also offer new ways of networking and communicating. The social media give endangered language users the opportunity of creating their own virtual communities and networks bridging the gaps caused by language shift and helping isolated individual language learners practice their skills with others (e.g., Holton 2011, p. 371).

While the benefits of the new technologies in language maintenance are emphasized, critique has also been voiced. Eisenlohr (2004) discussed how practices of electronic mediation and language ideologies are necessarily embedded in, and are related to, the sociocultural processes of language obsolescence and revitalization. What does the fact that new technology not only mediates linguistic practice but also adds new forms and social functions to the language concerned mean in the context of cultural endangerment? The notion of minority language ownership and the role of speakers are also actualized when electronic media are used for documenting and spreading knowledge of a language worldwide (Henderson 2013). The scholarly discussion concerning the benefits, drawbacks, and ethical issues of modern technologies in the field of endangered languages is likely to continue and intensify in the future as a growing number of endangered language communities gain access to electronic resources. Holton (2011) cautions against an overreliance on the technology and reminds us that neither CD-ROMs, multimedia websites, electronic dictionaries, nor anything else can themselves revitalize a language or create new speakers. What information technology *can* do is to unite dispersed language communities and to “contribute to the development and appreciation of endangered languages in new terms” (Holton 2011, p. 398), something which is more likely to happen, as Holton points out, when endangered language speakers and learners become practicing creators, not only consumers of information technology.

---

## Problems and Difficulties

### From “Neutral Research” to Advocacy

Since the early 1990s, there has been active debate on the role of the researcher in maintenance, loss, and revitalization research. The central question was at first whether the researcher should (or even could) maintain a “neutral” position, observing and describing the endangered language and accepting its imminent death as natural. Or whether it was legitimate (or even desirable) that researchers become engaged in actively assisting the community in their language maintenance efforts. The latter position started gaining ground in the 2000s when more and more scholars were moving toward advocacy, some of them seeing the extinction of the world’s languages as serious a thing as the diminishing of biological diversity (e.g., Skutnabb-Kangas 2000). However, what was described “responsible linguistics,” “reformed linguistics,” or “preventive linguistics” was early on subject to suspicion and negative labeling (e.g., Edwards 2002).



## Collaboration Between Researchers and Communities

Numerous conferences and workshops held during the last few decades in the field of language endangerment and revitalization have shown that close links have been established between researchers from various countries on one hand and between researchers and practitioners on the other hand. An early example of the latter is a series of symposia titled *Stabilizing Indigenous Languages*, which started already in 1994. The goal of the symposia series is to bring together indigenous language educators and to provide a forum for exchange of scholarly research on the teaching of indigenous languages (see <http://jan.ucc.nau.edu/~jar/History.html>). An example of another kind of cooperation between endangered language speakers and scholars (linguists) is the *Breath of Life Language Restoration Workshop* series started by the *Advocates for Indigenous California Language Survival* to enable individuals to reclaim their languages with the help of archival materials (<http://www.aicls.org/#!breath-of-life/cd1c>).

The general trend among researchers of endangered languages to collaborate with speaker communities for language promotion and to engage community members in research, and sometimes also in research publication, seems to be growing stronger in various parts of the world (cf. Cruz and Woodbury 2014; Granadillo and Orcutt-Gachiri 2011; Olthuis et al. 2013). As Granadillo and Orcutt-Gachiri stated, “our work grows out of a desire to both cast a critical eye on the situation of endangered languages and share theoretical tools to help researchers and communities change that situation” (p. 1).

While the ethical side – the need for researchers to “give something back” to the community and to empower community members – remains an important issue in this context, other benefits of researcher–community collaborations are also mentioned. Engaging community members in fieldwork as coresearchers (e.g., as in “collaborative” or “participatory” anthropology) also means that communities are given the right to define their own problems and to negotiate solutions which makes it the most efficient and adequate way to address local problems. Therefore, participation is not only about rights and ethics but also about efficacy (Roche et al. 2010, p. 156).

Collaborations are needed to build capacity so that communities will not be dependent on outside researchers in the long run. Also, in researcher–community cooperation, the local context with all its special features becomes central, which is essential. It appears harder and harder to understand language loss or language maintenance in a general way; it is necessary to study every particular speech community extensively in its special context to be able to, for example, design a language maintenance effort that would fit that specific situation (Sicoli 2011, pp. 163–164).

Dedicated and long-term work is also needed to build trust and avoid exploitation or breach of confidence. This can be challenging, irrespective of whether the researcher finds the settings for the fieldwork unfamiliar and culturally remote or seemingly familiar (Dorian 2014, p. 421).

---

## Defining “Success” Versus “Failure” in Language Revitalization

A special difficulty connected to research on language revitalization concerns defining when a revitalization movement has been successful and when not. Which criteria should be used to assess the outcome, and who should have the right to choose the criteria?

Different revitalization movements may have very different goals and also different ways of defining their own success or failure. Moreover, as Fishman aptly concluded about “failure,” “. . . it not only depends on the eyes of the beholder, but the same beholder may evaluate it differently on two different occasions separated by little if any elapsed time” (Fishman and García 2011, p. 5).

The stated goals vary from situation to situation and from case to case. In the case of extremely endangered or even moribund languages, the goal of documenting the language and promoting conversational competence in it might well be sufficient, while in other cases, the promoters of a language might aim, for instance, at promoting literacy in the language through school education (Reyhner 1999).

Another question is whether we can really assess the outcome by studying the situation as it is at a certain point of time, without knowing, and wisely refraining from guessing what will happen in the future. There are cases with a strong long-term tendency pointing toward language death when the situation suddenly alters and a new, opposite tendency appears. There are today many cases where a language that has not been spoken by anybody in decades is revived and taken into use in some domains (e.g., Amery 2000). Endangered language communities worldwide are challenging former negative prognoses about their languages by engaging in community efforts that are both “bringing the languages home” (Hinton 2013) and empowering their speakers.

---

## Future Challenges

Ultimately, the fate of languages and language revitalization movements is sealed by language choices made by individuals and individual families. As has been shown in history, overt assimilation policies have not always been able to obliterate minority languages neither have supportive policies been able to guarantee the maintenance and revitalization of endangered languages. Speaker agency and personal language ideologies often turn out to play a more important role than the macrostructural context (Granadillo and Orcutt-Gachiri 2011, pp. 10–11).

It is therefore necessary to seriously take into consideration what community members think and feel about their languages and what their own language ideologies are in order to get a deeper understanding of the language loss or revitalization process. Reclaiming a language is rarely an easy process although the learner is strongly motivated (e.g., King and Hermes 2014). Strong negative feelings, painful memories, and conflicting personal language ideologies often seem to hinder language reclamation in spite of state policies explicitly promoting minority or indigenous languages.

Families as agents in responding to official language policies, and shaping their own ones, have during the past decade begun to attract more interest among researchers and are today a growing field of study. Individual families, not isolated but influenced by other significant domains with their respective language policies, such as neighborhood, preschool, school, and others, are sites where language policies are created and language choices made and reacted on, not only by the parents but also by their children. Family language policy-making in the context of language loss and revitalization still remains a largely unresearched area, while there are many documented examples of such endeavors (e.g., Hinton 2013).

Young people should also get their due focus in studies of language maintenance and revitalization, but research on teenagers and young adults is still very scarce in this context. The young are often viewed by leaders of revitalization movements as those who are prone to be influenced by the majority society and its dominant language ideologies, eager to leave the local community and adapt to urban life which is often seen as the greatest hindrance to revitalization efforts. Many movements seem at a loss when they find themselves unable to attract the younger generations to the degree they would like to.

However, some recent research shows that much of what was formerly taken for granted in many minority language situations is now questioned. One example is the common either-or character of language choices perceived to be available for young minority language speakers. They are supposed to be either maintaining the language and identity and staying in the community or shifting to the majority language and urban life for mobility, education, and employment. In reality, the alternative of having both exists for many. Multilingual speakers are now in research focus and the relevance of the “urban–rural divide” is questioned (e.g., May 2014).

Multilingual repertoires and abstention from strict linguistic norms are today characteristic of large numbers of multiethnic young people especially in greater urban centers. This reminds us of the claim from critical sociolinguistics that languages, bounded and strictly isolated from each other, are human inventions and should therefore be disinvented and reconstituted, in order to lead to less linguistic purism, to more acceptance of real-life individuals with fused multilingual repertoires, and thus to better conditions for minority language speakers (Makoni and Pennycook 2007).

The fact that particular languages or language varieties – however invented – nevertheless do play a significant role for certain ethnic identities is confirmed by a growing number of individual and community-based language reclamation projects worldwide. Even in the repertoire of a multilingual person, the minority language(s) can play an important role. Still, common problems emanating from the traditional view of languages as bounded and reified concepts remain to solve for revitalists: linguistic purism in language renewal inhibiting potential speakers, territorial restrictions regarding minority and indigenous language rights, and conflicting language ideologies inside and outside communities. More studies on generational as well as gender differences in responding to challenges of this kind are needed to shed more light on the prospects of community-based language revitalization.

---

## Cross-References

- ▶ [Ethnography of Language Policy](#)
- ▶ [Researching Historical Perspectives on Language, Education, and Ideology](#)
- ▶ [Theoretical and Historical Perspectives on Researching the Sociology of Language and Education](#)

---

## Related Articles in the Encyclopedia of Language and Education

- Kendall King: [Family Language Policy](#). In Volume: Language Policy and Political Issues in Education
- Leanne Hinton: [Language Endangerment and Revitalization](#). In Volume: Language Policy and Political Issues in Education
- Lynn Fogle and Kendall King: [Bi- and Multilingual Family Language Socialization](#). In Volume: Language Socialization
- Onowa McIvor and Teresa L. McCarty: [Indigenous Bilingual and Revitalization-Immersion Education in Canada and the United States](#). In Volume: Bilingual and Multilingual Education

---

## References

- Aikio, M. (1988). *Saamelaiset kielenvaihdon kierteessä. Kielisosiologinen tutkimus viiden saamelaiskylän kielenvaihdosta 1910–1980 [The Saami in the process of language shift. A sociolinguistic study on language shift in five Sámi villages during 1910–1980]*. Helsinki: Suomalaisen Kirjallisuuden Seura.
- Amery, R. (2000). *Warrabarna Kurna! Reclaiming an Australian language*. Lisse: Swets and Zeitlinger.
- Crawford, J. (2000). *At war with diversity: U.S. language policy in an age of anxiety*. Clevedon: Multilingual Matters.
- Cruz, E., & Woodbury, A. C. (2014). Collaboration in the context of teaching, scholarship, and language revitalization: Experience from the Chatino. *Language Documentation*, 8, 262–286.
- Crystal, D. (2000). *Language death*. Cambridge: Cambridge University Press.
- Dorian, N. (1981). *Language death: The life cycle of a Scottish Gaelic dialect*. Philadelphia: University of Pennsylvania Press.
- Dorian, N. (1993). Discussion note, a response to Ladefoged's other view of endangered languages. *Language*, 69(3), 575–579.
- Dorian, N. (1998). Western language ideologies and small-language prospects. In L. A. Grenoble & L. Whaley (Eds.), *Endangered languages, language loss and community response* (pp. 3–21). Cambridge: Cambridge University Press.
- Dorian, N. C. (2014). *Small-language fates and prospects. Lesson of persistence and change from endangered languages [Collected Essays]*. Boston: Brill.
- Edwards, J. (1991). *Multilingualism*. Oxford: Routledge.
- Edwards, J. (2002). Forlorn hope? In L. Wei, J.-M. Dewaele, & A. Housen (Eds.), *Opportunities and challenges of bilingualism*. Berlin: Mouton de Gruyter.
- Eisenlohr, P. (2004). Language revitalization and new technologies: Cultures of electronic mediation and the refiguring of communities. *Annual Review of Anthropology*, 33, 21–45.

- Fillmore, L. W. (1991). When learning a second language means losing the first. *Early Childhood Research Quarterly*, 6, 323–346.
- Fishman, J. (1966). *Language loyalty in the United States; the maintenance and perpetuation of non-English mother tongues by American ethnic and religious groups*. The Hague: Mouton.
- Fishman, J. (1991). *Reversing language shift: Theoretical and empirical foundations of assistance to threatened languages*. Clevedon: Multilingual Matters Ltd.
- Fishman, J., & García, O. (Eds.). (2011). *Handbook of language and ethnic identity. The success-failure continuum and ethnic identity efforts* (Vol. 2). New York: Oxford University Press.
- Gal, S. (1979). *Language shift: Social determinants of linguistic change in bilingual Austria*. New York: Academic.
- Granadillo, T., & Orcutt-Gachiri, H. A. (2011). Introduction. In T. Granadillo & H. A. Orcutt-Gachiri (Eds.), *Ethnographic contributions to the study of endangered languages* (pp. 1–12). Arizona: University of Arizona Press.
- Grenoble, L. A., & Whaley, L. J. (Eds.). (1998). *Endangered languages: Current issues and future prospects*. Cambridge: Cambridge University Press.
- Haugen, E. (1953). *The Norwegian language in America: A study in bilingual behavior I–II*. Philadelphia: University of Pennsylvania Press.
- Henderson, J. (2013). Language documentation and community interests. In M. C. Jones & S. Ogilvie (Eds.), *Keeping languages alive. Documentation, pedagogy, and revitalization* (pp. 56–68). Cambridge: Cambridge University Press.
- Hinton, L. (Ed.). (2013). *Bringing our languages home. Revitalization for families*. Berkeley: Heyday Books.
- Hinton, L., & Hale, K. (Eds.). (2001). *The green book of language revitalization in practice*. San Diego: Academic.
- Holton, G. (2011). The role of information technology in supporting minority and endangered languages. In P. K. Austin & J. Sallabank (Eds.), *The Cambridge handbook of endangered languages*. Cambridge: Cambridge University Press.
- Hornberger, N. (Ed.). (2007). *Can schools save indigenous languages? Policy and practice on four continents*. Hampshire: Palgrave Macmillan.
- Huss, L., & Lindgren, A.-R. (2011). Introduction: Defining language emancipation. In L. Huss & S. Nolan (Eds.), *The many faces of language emancipation* [Special Issue]. *International Journal of the Sociology of Language*, 209, 1–15.
- Huss, L., Camilleri Grima, A., & King, K. (2003). *Transcending monolingualism. Linguistic revitalization in education*. Lisse: Swets and Zeitlinger.
- Jaakkola, M. (1973). *Språkgränsen: en studie i tvåspråkighetens sociologi* [Language border: A study in the sociology of bilingualism]. Stockholm: Aldus/Bonnier.
- King, K. (2001). *Language revitalization processes and prospects: Quichua in the Ecuadorian Andes*. Clevedon: Multilingual Matters Ltd.
- King, K. A., & Hermes, M. (2014). Why is it so hard?: Ideologies of endangerment, passive language learning approaches, and Ojibwe in the United States. *Journal of Language, Identity & Education*, 13(4), 269–282.
- Krauss, M. (1992). The world's languages in crisis. *Language*, 68(1), 4–10.
- Kulick, D. (1992). *Language shift and cultural reproduction: Socialization, self, and syncretism in a Papua New Guinea Village*. Cambridge: Cambridge University Press.
- Lambert, W. E. (1974). Culture and language as factors in learning and education. In F. E. Aboud & R. D. Mead (Eds.), *Cultural factors in learning and education*. 5th Western Washington Symposium on Learning, Bellingham.
- Makoni, S., & Pennycook, S. (Eds.). (2007). *Disinventing and reconstituting languages*. Clevedon: Multilingual Matters.
- May, S. (2014). Contesting metronormativity; exploring indigenous language dynamism across the urban-rural divide. *Journal of Language Identity & Education*, 13(4), 229–235.
- McCarty, T. L. (2002). *A place to be Navajo: Rough rock and the struggle for self-determination in indigenous schooling*. Mahwah: Erlbaum.

- Norberg, M. (1996). *Sprachwechselprozess in der Niederlausitz. Soziolinguistische Fallstudie der deutsch-sorbischen Gemeinde Drachhausen/Hochoza* [Language shift process in Niederlausitz: A sociolinguistic case study on the German-Sorbian community Drachhausen/Hochoza] (Doctoral dissertation). Retrieved from ProQuest. (C503412).
- Olthuis, M.-L., Kivelä, S., & Skutnabb-Kangas, T. (2013). *Revitalising indigenous languages: How to recreate a lost generation*. Bristol: Multilingual Matters.
- Reyhner, J. (1999). Introduction: Some basics of indigenous language revitalization. In J. Reyhner, G. Cantoni, R. N. St. Clair, & E. P. Yazzie (Eds.), *Revitalizing indigenous languages*. Flagstaff: Northern Arizona University.
- Roche, G., Ban+de mkhar, Bkra shis bzang po, G.yu lha, Snying dkar skyid, Tshe ring nmam gyal, Zla ba sgrol ma, Charles Kevin Stuart (2010). Participatory culture documentation on the Tibetan Plateau. In I. Gunn & M. Turin (Eds.), *Language documentation and description: Vol. 8. Special issue on oral literature and language endangerment* (pp. 140–158). London: SOAS.
- Sicoli, M. (2011). Agency and ideology in language shift and language maintenance. In T. Granadillo & H. A. O. Gachiri (Eds.), *Ethnographic contributions to the study of endangered languages*, (pp. 161–176). Tucson: University of Arizona Press.
- Skutnabb-Kangas, T. (2000). *Linguistic genocide in education or worldwide diversity and human rights?* Mahwah: Erlbaum.
- Stiles, D. B. (1997). Four successful indigenous language programs. In J. Reyhner (Ed.), *Teaching indigenous languages* (pp. 148–262). Flagstaff: Northern Arizona University.
- Stordahl, V. (1996). *Same i den moderne verden. Endring og kontinuitet i et samisk lokalsamfun* [To be Sámi in the modern world: Change and continuity in a Sámi community] (Unpublished doctoral dissertation). University of Tromsø, Norway.
- Todal, J. (2002). “-jos fal gáhttet gollegielat”: vitalisering av samisk språk i Noreg på 1990-talet [“-if only you safeguard your golden language”: Vitalization of the Sámi language in Norway in the 1990s. Tromsø: University of Tromsø.
- Weinreich, U. (1953). *Languages in contact*. The Hague: Mouton.

---

# Researching Media, Multilingualism, and Education

Ingrid de Saint-Georges

---

## Abstract

The media are a particularly rich site for investigating multilingual practices – the things people do when they draw upon more than one language to communicate or act. It is also a highly relevant context to examine various forms of formal and informal learning processes. It is thus not surprising if the past decade has witnessed a booming body of research engaged with the nexus of multilingualism, media, and education, as intersecting fields of investigation.

This chapter traces how progressive changes in the mediascape have raised simultaneously new methodological challenges for researchers interested in multilingual practices in/of the media and in investigating the role of the media in formal and informal learning processes. This chapter takes a broad view of the media, incorporating discussions related to the printed press, radio, and television broadcasting, the entertainment industry, as well as the Internet, recognizing that in the new media sphere these media tend to converge. Taking a close look at international research in the field, the review shows how different research questions and strategies have developed over time to keep abreast of transformation in the media sphere while also reflecting the development of the field of sociolinguistics. As a result, many options are today available to conduct research about media, multilingualism, and education, with no single one occupying a privileged position.

---

## Keywords

New media • Multilingualism • Informal learning • Research design • Digital technology • Ethics • Internet • Media research • Social media • Broadcast media • Multilingual internet • Standardization • Computer-assisted language learning

---

I. de Saint-Georges (✉)

Educational Science, University of Luxembourg, Belval, Luxembourg

e-mail: [ingrid.desaintgeorges@uni.lu](mailto:ingrid.desaintgeorges@uni.lu)

## Contents

Early Developments .....	114
Major Contributions .....	116
Work in Progress .....	118
Problems and Difficulties .....	120
Future Directions .....	121
Cross-References .....	123
Related Articles in the Encyclopedia of Language and Education .....	123
References .....	123

## Early Developments

Boyd-Barrett et al. (1996) are often heralded as the first thorough review of the field of “multilingualism and the mass media.” In this review, the authors note that at the end of the 1990s, the interest in this topic is rather marginal and eclectic. When discussions comes up about multilingualism and the media, it is mainly related to other broader topics, such as the role of languages in consolidating the nation-state, the rise of movements for minority language rights, the role of technologies in sustaining or erasing cultural and linguistic diversity, and imperialism. To understand why discussions about “multilingualism *in* the media” and “*of* the media” do not abound at the time (Kelly-Holmes and Milani 2013), it is useful to remember that up to that period, *stricto sensu*, in many Western countries, there are not many multilingual practices visible in the media and education, mainly because these practices are largely “edited out,” invisibilized or limited to token items.

In the 1970s and 1980s, the broadcast media, with their monolingual and standardized linguistic habitus, function in many countries very much as an institutional instrument for consolidating the nation-state. If we take the radio as an example, radio anchors not only speak the national language but also very often its most prestigious variety, thus contributing to promoting this variety as the norm. As a result, in such media, a monolingual ideal dominates (Androutsopoulos 2007). The language varieties of laypeople are not typically heard in this public space, and if they are, it is mostly in entertainment programs such as “talk” radio (when an audience member “phones-in” to exchange with the talk show host). As for the voices of those speaking “with an accent” (Lippi-Green 1997) or in another language, they remain typically unheard in the mainstream broadcast media, unless minority movements manage to claim wave space and challenge the monopoly of the state, by setting up, for example, their own broadcasting channels. In this context, what interests a majority of researchers is to examine processes of standardization and de-standardization and vernacularization of the media. To study these processes, researchers typically adopt a Labovian kind of approach. They study large corpora for their language feature and variables and examine different styles of use and their variations.

A similar situation is found in the entertainment industry, in which the same monolingual habitus ideal dominates. In a famous study, Lippi-Green (1997) screened animated Disney films for the language variety spoken by the main characters. Through a quantitative analysis, she finds out that systematically, the



characters with the most positive evaluations are also those using the more mainstream US accents, while other “accented” varieties of English are kept for less likeable characters. In films (Bleichenbacher 2008), advertising (Cheshire and Moser 1994), radio shows (Coupland 2001), or TV broadcasts (Jaworski et al. 2003; Piller 2001), many studies will subsequently corroborate that when other languages or other varieties of one language are used in the media, it is often for “stylizing” an exotic other for a majority audience (Androutsopoulos 2007, p. 213). That is, when a language is used in the media that is different from the dominant language in the community, it is used for entertainment purposes, to index the specific identity of a national “other” but usually not to make deep, profound points. In methodological terms, initial contributors to this line of research show how quantitative approaches can be revealing of patterns of language use that reflect deeply entrenched social prejudices or stereotypes.

The early and mid-1990s mark a huge turn for the media landscape as they correspond to the emergence of the Internet and the World Wide Web. As a global network, the Internet seems at first to offer the promise of a truly pluralistic and multilingual platform. But the early days bring disenchantment as, at the time, the Internet is first and foremost an English network. The majority of sites and users are English speaking or use English as lingua franca. Many researchers underline that the ASCII code used for computing makes it difficult to use other character sets than the English set (Danet and Herring 2007; Leppänen and Peuronen 2012). They also research the creative ways users find to overcome these limitations (e.g., romanizing scripts or playing with typographic, orthographic, or linguistic conventions; Paolillo 1996) again with a mainly quantitative outlook.

With regard to education, there too a monolingual habitus dominates largely. If the media very early on are perceived as a formidable tool for both formal and informal education, they are specially mobilized in language education. The 1960s, for example, is a period where many educational settings become equipped with language labs. First audio- and then video-recorded material become used within the classroom or for independent learning. The 1970s, 1980s, and 1990s see the development of educational TV programs and in particular of programs meant to democratize the first steps into literacy (e.g., *Sesame Street*) or foreign language learning (e.g., *Muzzy in Gondoland*, *l'Anglais avec Victor*, *French in Action*). Edutainment is made available on mainstream broadcast TV and radio as a means of distance education for both children and adult alike. In the 1980s, the spread of microcomputers and the development of the videodisk signify the beginning of multimedia education and mark the start of what will later be called the field of CALL – or computer-assisted language learning (Hubbard 2009).

In this early period, a common situation dominates: there is little visibility of multilingual practices, which are reserved for the privacy of the home but not viewed as legitimate in the public or educational sphere. In addition, much of the research that ventures in analyzing multilingual practice take a quantitative, statistical point of view and, on the whole, do not make much provision for the contextual dimension of the language data collected.

## Major Contributions

The year 2000 marks the beginning of a multilingual turn in media research, stimulated by two major sociocultural changes affecting deeply the “public display of diversity” (Androutsopoulos 2007, p. 208). One is the acceleration of globalization. With increased mobility of people, ideas, and goods, multilingual practices become more visible, and topics such as the articulation of the local and the global, multilingual audiences, or transnationalism come to the fore in media research. The second major change is the transformation of conditions for media production and media reception. Whereas before the production of media content was still very much in the hands of professionals, with new technological developments, lay users can now produce, edit, and comment content on the Web, and they do so drawing from the variety of linguistic repertoires that are available to them (Androutsopoulos 2007, p. 208).

With these changes, new practices of multilingualism begin to emerge. As Androutsopoulos (2007) notes, media users can now easily switch codes in ordinary exchanges (e.g., on email, instant messaging); minority group activists as well as diaspora members are afforded access to and visibility in the public sphere through the Internet, blogs, or online newspapers; advertisers have the possibility to target their sales pitch to always more specific linguistic or cultural niches; and artists can sample and mix media content from all over the world (p. 208). With the diversification of languages on the Internet, it becomes usual to navigate from content in one language to content in another when browsing the Web. In order to meet the challenge of accessing this multilingual content, machine translation programs continue developing (e.g., SYSTRAN, BabelFish, WordLingo, or Google Translate). In parallel, public and individual initiatives proliferate to offer (foreign language) educational resources. This is also a period where studies of multilingual practices multiply, whether focusing on print media (Kelly-Holmes and Milani 2013), advertising (Kelly-Holmes 2005), or the entertainment industry (Bleichenbacher 2008; Budach 2008).

In this context, two trends of research begin to be distinguishable as Kelly-Holmes and Milani underline (2013): investigations that focus on analyzing which languages are represented *in* the media, paying particular attention to which ones are visible, what their status is, and how they are talked about, and studies looking at the multilingual practices of the users *of* the media, paying more specific attention to how people use the affordances of an L1, L2, and other languages to communicate, act, or negotiate identities. With these research foci also come different methodological takes.

For a while, for example, measuring language choice and diversity on the Internet is high on researchers' agenda. The issue is to determine whether the Internet weakens the status of minority languages because of the domination of larger languages or on the contrary offers a public space for languages hitherto hidden or unwanted in traditional media to gain visibility. Such studies make use of quantitative survey methodologies to attempt to provide an index of global diversity. As Paollilo (2007) shows, however, it is extremely challenging to find figures which account in an uncontroversial way for the proportion of different language use on the Internet.

Other research use more traditional sociolinguistic approaches. Pioneering researchers in the field of computer-mediated communication favor techniques drawn from variation analysis, consisting in coding and counting structural units of analysis and correlating them with linguistic and nonlinguistic variable (Herring 2004). They focus, among others, on variations between spoken and written features of texts, grammatical and orthographic substitutions, and how they correlate with age, genre, or gender. With this research, scholars establish the patterned dimension of language variation online. As Androutsopoulos (2011, p. 278–279) notes, however, such studies have inherent limitations. Firstly, they are more suitable to the study of the more conversational practices online (email, mailing lists, Internet Relay Chat, and instant messages) than more static genres. Secondly, as the categories are related to single linguistic systems, they cannot appropriately address multilingual practices and code-switching. Thirdly, the analytical focus both on the linguistic system exclusively and on “counting” tends to exclude from analysis anything that (i) is not a linguistic variable (e.g., emoticons and script choice), (ii) cannot be counted easily, or (iii) appears infrequently.

The publication of the special issue *Multilingualism on the Internet* (Wright 2004) and of the volume *The Multilingual Internet* (Danet and Herring 2007) marks another transition in linguistic research on computer-mediated communication. In the first, UNESCO-sponsored, project, a common macrosociological research design is adopted by all authors, who use a survey to investigate preferred language use of 300 university students in ten different countries, with the aim of understanding what happens in situations of language contact for these students. Do they prefer to use English? What happens across language boundaries? (Wright 2004, p. 8). The second volume (Danet and Herring 2007) takes a more mixed approach, combining micro- and macrosociolinguistic tools to study a range of languages, geographical locations, and usage. Their point of departure is that the majority of Internet users are people for whom English is not their first language. They have thus several options: they can use English as a lingua franca, they can mix English with their first language or other languages that they know, or they can code-switch between English and other languages. With this range of possibilities, it becomes interesting to study the specific multilingual practices of Internet users, the motivations behind their language choices, and the functions and meanings they assign to them in the specific media context in which they operate.

In this context, researchers begin to convoke tools from interactional sociolinguistics, pragmatics, conversational analysis, genre analysis, and discourse studies. They use them to approach traditional sociolinguistic issues such as the construction and negotiation of identity, socialization processes into online communities, the construction of turn-taking, politeness and terms of address, or the study of code-switching online. They seek to develop an understanding of how these dimensions might be shaped by the demographics of chat rooms, the transnational character of a forum or a gaming environment, the specificity of a particular genre (email, user discussion list), or the sociolinguistic context of the author and its presumed audience. With this sort of studies, more attention is paid to discursive and social contexts, but a strong focus on studying log data still predominates.

A third type of approach, inspired by sociology and language ideology as well as critical approaches to language, consists in focusing on discourse analysis of micro-level features of media language to identify how these are shaped or are shaping social ideology. Traditional newspapers, TV, and films are the main media investigated in this vein (Johnson and Ensslin 2007). Researchers consider that folk linguistic theories about language can be found in the (mass) media and that investigating them opens a window for understanding language ideologies, categorization, stereotyping, language regimes, and language hierarchies.

What characterizes investigation of “multilingualism in the media” at the turn of the millennium then is that, on the one hand, the research very much draws on well-established approaches in sociolinguistics and discourse analysis. On the other hand, the specificities of the communicational landscape created by the new media also lead researchers to adjust and adapt their methods of data collection and analysis. Still only few research concentrates on the nexus of media, multilingualism, and education.

---

## Work in Progress

The years 2005 and onward witness the further diversification of languages on the Web making obsolete all predictions from the 1990s that English would end up dominating the Internet. In fact, multilingual practices become even more present and visible, as more people draw on more varied multilingual repertoires. Statistics from the Internet World Stats (2010) show, for example, that for 73% of Internet users, English is not their first language and that Chinese and Spanish have become prominently used languages on the net. The Web content in English has likewise decreased from 80% to 55% between 1998 and 2012 (Barton and Lee 2013, p. 43–44). As Barton and Lee point out (*ibid.*, p. 11), even users that would have been previously categorized as monolinguals now find themselves exposed on a regular basis to multilingual texts and practices. In Europe and elsewhere, diversity in education becomes likewise more visible with mobility and migration reaching new heights.

From a methodological perspective, the Web 2.0 challenges again discourse analysts, pushing them to explore new methodological directions. Jones and his colleagues (2015) highlight that the multimodal nature of digital texts calls for approaches that go beyond analyzing solely written and spoken language; the interactive features of social media with their options for commentary also transform the relationship between authors and readers and subverts tradition categories such as what is a “text” and what counts as a “conversation.” Studying ideologies in the new media context requires also honing new tools as in digital environments loci of power, control, and authority are more diffused and variegated (p. 1). During this period, both traditional theories and methods continue to be cultivated, while new strands of research also develop alongside them to address new emergent questions. Here, too different methodological approaches are taken.

One first avenue consists in moving away from focusing exclusively on communication in the media as text and as language, to begin exploring the practices of media consumers and producers (at the intersection of online and offline practices) (Barton and Lee 2013, p. 165; Kelly-Holmes 2015). To do so, investigations of new media start including an ethnographic outlook, combining the analysis of text and language with surveys, interviews, and participant observation in order to understand people's everyday (digital) media practices. While some researchers limit their observations to what is going on in online communities with or without interacting directly with their members, others are interested in uncovering the continuities and discontinuities between online and offline practices by both observing discourse online and interviewing Internet actors to elicit their emic perspective about their practices, an approach Androutsopoulos (2008) also calls "discourse-centered online ethnography."

Connecting traditional linguistic analyses with practice-based approaches also lead researchers to think up new solutions to methodological problems. Increasingly, they adopt, for example, mixed-method approaches. This view contends that no single approach is suitable for examining language as/in practice but that a mix of both quantitative and qualitative methodologies is necessary to approach the complexity of situated multilingual practices online. To do this, researchers continue to use logbooks and online and face-to-face interviews. They do "persistent observations," descriptive statistics, and surveys but add also techno-biographies, multi-modal analyses of users productions, diary entries (Barton and Lee 2013, p. 167–174), as well as focus groups, simulated recall sessions, video observations, the gathering of photographic data, auto-(n)ethnography, and object ethnography (Jones et al. 2015). With experimenting with new designs, it becomes clear that digital communication is not just the object of research but also a research instrument itself. Barton and Lee (2013, p. 173) note, for example, that in interviews through ICT, not sharing physical space might have interesting side effects: the interviewee feels more comfortable and shares more private and personal information. While waiting for the respondent to finish typing up an answer, the researcher has also more time for reflection. She can think about which questions to ask next without being caught in the immediacy of the interaction, which allows for carefully constructed data.

With regard to learning and education, researchers continue to ask themselves about the extent to which the media, and in particular digital media, can constitute a resource for teaching and learning. Do they allow more autonomous forms of learning? To what extent do they help teachers connecting more with the practices and interest of their learners? (Benson and Chan 2011; Lamy and Zourou 2013). How can digital technology contribute to give a voice to plurilingual students? Anderson and his colleagues (2015), Barton and Lee (2013), and Walker (2014) review different strategic uses by teachers of the new media in the classroom: video games can become a resource for second language learning, virtual worlds such as Second Life can serve in making interactions less intimidating for the less outspoken students, and Facebook and microblogging are used to practice argumentation and writing. In a globalized online space, the practice of foreign languages becomes less

restricted and artificial as students have the opportunity to engage regularly in genuine translingual activities with native speakers of a language even without traveling.

Outside the classroom, researchers show that the new media are also a powerful place for everyday, “informal,” or “vernacular” learning (Barton and Lee 2013). Individuals use YouTube videos, films, music, e-books, Facebook posts, blogs, and the press as stepping stones to process, elaborate, and construct their own meanings and personal cultural repertoires. Benson and Chan (2011) show, for example, that the practice of subtitling videos by fans or “fansubbing” and the forum discussions to resolve question provides a lively space for learning and discussing language as people comment and correct translations. Likewise, Barton and Lee (2013, p. 126–136) discuss how engaging in an activity such as “taking a photo a day” and posting it daily on Flickr is a learning practice leading participants to exchange with others, reflect upon their participation, deliberately seek advice about problems, receive positive feedback, find mentors, and through all this activity, develop new identities through practice. The authors argue that the sort of learning afforded by the media differs from more institutional forms of learning in that it is incidental and not controlled by any authority but rather depends on the learners own motivated goals and engagement in practice.

---

## Problems and Difficulties

One major challenge for researchers is that the media keeps changing, transforming researchers’ understanding of what is a text, what count as an action or an interaction, what is context, what is power, and who has it (Jones et al. 2015, p. 1). In such a context, it is important to move beyond mere descriptive analyses of the multilingual practices that the new media afford, and start asking “why” do multilingual practices change and “what changes” in the world because of these new practices. For example, how do choices at the individual level (such as responding to a comment in one’s language or seeing more films with dialogues in foreign languages) is connected to a broader social picture (transforming language policies from below)? Or, how do such practices change our view on learning in general and language learning in particular? Do people learn, in fact, differently since the advent of new technologies?

Another major issue with media research relates to ethics. The question of ethics has been a hot topic for researchers of media practice for a long time as the new media are partially a public and partially a private space where the issue of ownership and right is dealt with differently in different national legal systems. Obtaining informed consent in advance is not always possible when newcomers keep on joining an online community. Many researchers are also participants in the practices they research, calling into question the naturalness of the data. The potential invisibility of the researcher doing persistent observation as a lurker might also raise questions about participants’ awareness that they are part of a study. A sensitive and flexible approach is often required in that context, determined by the specificity

of the project undertaken, the media researched, the content, and the potential risk of harming people with the study (Barton and Lee 2013; Herring 2002). In that sense, new technologies only exacerbates the old questions linked to dealing with human subjects.

A third issue concerns the role and place of the researcher. In new media research, Davies and Merchant (2009, p. 173) note that investigators typically occupy one of several positions. Sometimes they are the “identifiers of new tropes” as, for example, when they put a name on a previously undiscussed phenomenon such as “Netspeak.” Sometimes they are “insiders,” looking at the digital practices of others while also having a history of using the technology themselves. At yet other times, they can turn their own practices into objects of analysis (e.g., doing auto-ethnography) and thus being both “subjects and objects” in the research process or become engaged on questioning the impact and effect of the new media and adopt an “activist” perspective. In the course of one’s work, it is not rare that the researcher moves across these different positions in order to make sense of the lived experience of the participants with the technology and to understand how digital practice is woven into the fabric of everyday life.

Finally, researching multilingualism means also that researchers have to integrate in the research process linguistic repertoires beyond their own if they want their research to be reflective of the diversity existing in contemporary society. Researchers in bilingual or multilingual settings have begun asking themselves what it means to produce knowledge involving more than one language, with questions such as: What is the role of translation, interpretation, collaboration, or mediation in the research process? How does doing research multilingually affect the research design, literature review, consent procedure, data generation, analysis, and reporting (Holmes et al. 2013)? What does researching multilingualism do to the hegemonic pressure of having English as the main language of international research? Overall, we see that there are many stimulating methodological and empirical questions that arise in examining the nexus of media, multilingualism, and education.

---

## Future Directions

Media support, production, and consumption keep on evolving and transforming rapidly, and multilingual practices are increasingly visible everywhere. If this trend continues in the future, as it is likely to do, this means that discussions about data and methods in researching the nexus of media, multilingualism, and learning have only begun. Consequently, more critical reflections will be needed in the future about data collection and analysis, ethical issues, vernacular learning, the application of traditional methods of data analysis to new technological and social contexts, the creative elaboration of new methods to face media changes, genre delimitation, or corpus design. For the time being, we can only play at listing some transversal areas that have the potentiality to attract more attention in the near future.

In the field of education, publications about social media in relation to learning and teaching are only taking off. Future research will likely explore the opportunities that available online tools offer to educators (Zourou 2012). Here, more investigations are needed about the relations between social media and (language) learning and teaching, the investigation of how socialization in networked spaces pertains to (language) learning (Lamy and Zourou 2013), or the commercial appropriation of bilingualism or trilingualism and the further commodification of language skills for the knowledge economy.

When multiple languages appear in the media (films, the press, songs, videos), they make possible “multilingual imagination” (O’Sullivan 2007). It becomes more difficult to tame or invisibilize diversity, and it generates new ways of thinking about, reacting to, adjusting to, or negotiating multilingual practices and identities. Fields of normativities also become challenged. One second area of research therefore relates to how norms will transform with the pull and push dimension of the media. Will there be a growth in global media products? A growth of minority language media, or continuing mixed practices? And what will be the role played by key actors and agents, media practices, and texts in these processes (Blommaert et al. 2009)?

Multilingualism also makes the question of mediation more visible. When one cannot assume anymore that the text, movie, song, news article, and advertisement produced will be destined to a monolingual audience, new issues related to understanding, translation, and mediation come into play. To paraphrase Egoyan and Balfour (2004), “every [text, film, image, discourse] is a foreign [text, film, image, discourse], foreign to some audience somewhere – and not simply in terms of language” (p. 21). One area that will require more attention in the years to come then might relate to processes of cultural and linguistic brokering, examining the resources the media might constitute for cultural exchanges across borders and for engaging in “critical connections” with others (Anderson et al. 2015).

According to Barton and Lee (2013, p. 183), with the new media, people engage in new forms of multilingual encounters; they have become more open to informality and language varieties different than their own; they reshape vernacular practices through making them public, legitimate, and acceptable; and they project and explore new and multiple identities and use multimodal resources to position themselves. As they do, new “contact zones” (Pratt 1991) appear that are sometimes spaces of learning and sometimes spaces of cultural friction and of awkward engagement. The challenge for researchers then is to find the methodologies that will allow to shed lights on the shared meaning-making, the divergent meanings, or the learning that arise between actors occupying different positions in the media field when they have access to different repertoires. It is likely that multi- and cross-disciplinary research beyond the realm of language studies alone might prove useful for this endeavor. As they have done in the past, researchers will continue venturing beyond their own field and expand the circle of analysis. They will creatively pursue new ways of answering the important linguistic and social questions they care about, sharing their results, and creating new forms of dialogues with both their fellow researchers and the public at large.



## Cross-References

- ▶ [Discourse Analysis in Educational Research](#)
- ▶ [Researching Computer-Mediated Communication](#)
- ▶ [Researching Multimodality in Language and Education](#)

---

## Related Articles in the Encyclopedia of Language and Education

Brook Bolander: [Identity in Mediated Contexts of Transnationalism and Mobility](#). In Volume: Language, and Technology

Deoksoon Kim and Oksana Vorobel: [Discourse Communities: From Origins to Social Media](#). In Volume: Discourse and Education

---

## References

- Anderson J., Macleroy V., Chung, Y.-C. (2015). Critical connections: Multilingual digital storytelling project. Handbook for teachers. [https://goldsmithsmdst.files.wordpress.com/2014/08/critical-connections-handbook\\_web.pdf](https://goldsmithsmdst.files.wordpress.com/2014/08/critical-connections-handbook_web.pdf). Accessed 15 Aug 2015.
- Androutsopoulos, J. (2007). Bilingualism in the mass media and on the internet. In M. Heller (Ed.), *Bilingualism: A social approach* (pp. 207–230). Basingstoke: Palgrave Macmillan.
- Androutsopoulos, J. (2008). Potentials and limitations of discourse-centered online ethnography. *Language@Internet*, 5. <http://www.languageatinternet.org/articles/2008/1610>. Accessed 15 Aug 2015.
- Androutsopoulos, J. (2011). From variation to heteroglossia in computer-mediated discourse. In C. Thurlow & K. Mroczek (Eds.), *Digital discourse: Language in the new media* (pp. 277–298). Oxford: Oxford University Press.
- Barton, D., & Lee, C. (2013). *Language online: Investigating digital texts and practices*. London: Routledge.
- Benson, P., & Chan, N. (2011). TESOL after YouTube: Fansubbing and informal language learning. *Taiwan Journal of TESOL*, 7(2), 1–23.
- Bleichenbacher, L. (2008). *Multilingualism in the movies: Hollywood characters and their language choices*. Tübingen: Francke Verlag.
- Blommaert, J., Kelly-Holmes, H., Lane, P., Leppänen, S., Moriarty, M., Pietikäinen, S., & Piirainen-Marsh, A. (2009). Media, multilingualism and language policing: An introduction. *Language Policy*, 8(3), 203–207.
- Boyd-Barrett, O., Nootens, J., & Pug, A. (1996). Multilingualism and the mass media. *Kontaktlinguistik/Contact Linguistics/Linguistique de Contact*, 12(1), 426–431.
- Budach, G. (2008). Une mine d'art: le rap montréalais et l'écriture. In J. Erfurt & G. Budach (Eds.), *Standardisation et déstandardisation. Le français et l'espagnol au XXème siècle/ Estandarización y desestandarización. El francés y el español en el siglo XX* (pp. 113–138). Frankfurt am Main: Peter Lang.
- Cheshire, J., & Moser, L.-M. (1994). English as cultural symbol: The case of advertisements in French-speaking Switzerland. *Journal of Multilingual and Multicultural Development*, 15(6), 451–469.
- Coupland, N. (2001). Dialect stylization in radio talk. *Language in Society*, 30(03), 345–375.
- Danet, B., & Herring, S.-C. (2007). *The multilingual internet: Language, culture, and communication online*. New York: Oxford University Press.

- Davies, J., & Merchant, G. (2009). Looking from the inside out: Academic blogging as new literacy. In M. Knobel & C. Lankshear (Eds.), *A new literacies sampler* (pp. 167–197). New York: Peter Lang.
- Egoyan, A., & Balfour, I. (Eds.). (2004). *Subtitles: On the foreignness of film*. Cambridge, MA: The MIT Press.
- Herring, S. C. (2002). Computer-mediated communication on the Internet. *Annual Review of Information Science and Technology*, 36, 109–168.
- Herring, S. C. (2004). Computer-mediated discourse analysis: An approach to researching online communities. In S. A. Barab, R. Kling, & J. H. Gray (Eds.), *Designing for virtual communities in the service of learning* (pp. 338–376). Cambridge: Cambridge University Press.
- Holmes, P., Fay, R., Andrews, J., & Attia, M. (2013). Researching multilingually: New theoretical and methodological directions. *International Journal of Applied Linguistics*, 23(3), 285–299.
- Hubbard, P. (2009). General introduction. In P. Hubbard (Ed.), *Computer assisted language learning: Foundations of CALL* (Vol. 1, pp. 1–20). New York: Routledge.
- Internet World Stats. (2010). Top ten languages used in the web. <http://www.internetworldstats.com/stats7.htm>. Accessed 15 Aug 2015.
- Jaworski, A., Thurlow, C., Lawson, S., & Ylänne-McEwen, V. (2003). The uses and representations of local languages in tourist destinations: A view from British TV holiday programmes. *Language Awareness*, 12(1), 5–29.
- Johnson, S., & Ensslin, A. (Eds.). (2007). *Language in the media: Representations, identities, ideologies*. New York: Continuum.
- Jones, R. H., Chik, A., & Hafner, C. A. (Eds.). (2015). *Discourse and digital practices: Doing discourse analysis in the digital age*. London: Routledge.
- Kelly-Holmes, H. (2005). *Advertising as multilingual communication*. Basingstoke: Palgrave Macmillan.
- Kelly-Holmes, H. (2015). Analyzing language policies in new media. In F. M. Hult & D. C. Johnson (Eds.), *Research methods in language policy and planning: A practical guide* (pp. 130–139). Malden: Wiley-Blackwell.
- Kelly-Holmes, H., & Milani, T. M. (2013). *Thematising multilingualism in the media*. Philadelphia: John Benjamins.
- Lamy, M. N., & Zourou, K. (Eds.). (2013). *Social networking for language education*. Basingstoke: Palgrave MacMillan.
- Leppänen, S., & Peuronen, S. (2012). Multilingualism and the internet. In C. A. Chapelle (Ed.), *The encyclopedia of applied linguistics*. Oxford: Wiley-Blackwell.
- Lippi-Green, R. (1997). *English with an accent: Language, ideology, and discrimination in the United States*. New York: Routledge.
- O’Sullivan. (2007). Multilingualism at the multiplex: A new audience for screen translation? *LANS-TTS*, 6, 81–95.
- Paolillo, J. C. (1996). Language choice on Soc. Culture. Punjab. *The Electronic Journal of Communication/La revue électronique de Communication*, 6(3). <http://www.cios.org/EJCPUBLIC/006/3/006312.HTML>. Accessed 15 Aug 2015.
- Paolillo. (2007). How much multilingualism? language diversity on the internet. In B. Danet & S. C. Herring (Eds.), *The multilingual internet: language, culture and communication online* (pp. 408–430). Oxford: Oxford University press.
- Piller, I. (2001). Identity constructions in multilingual advertising. *Language in Society*, 30(2), 153–186.
- Pratt, M.-L. (1991). *Arts of the contact zone* (pp. 33–40). New York: Modern Language Association.
- Walker, D. (2014). *A pedagogy of powerful communication: Youth radio and radio arts in the multilingual classroom*. New York: Peter Lang.
- Wright, S. E. (2004). Multilingualism on the Internet. Theme issue. *International Journal on Multicultural Societies*, 6(1). <http://www.unesco.org/shs/ijms>. Accessed 15 Aug 2015.
- Zourou, K. (2012). On the attractiveness of social media for language learning: A look at the state of the art. *Alsic*, 15(1). <http://alsic.revues.org/2436>. Accessed 15 Aug 2015.

---

# Researching the Continua of Biliteracy

Nancy H. Hornberger

---

## Abstract

The continua of biliteracy model offers an ecological framework in which to situate research, teaching, and language policy and planning in multilingual settings. Biliteracy is defined here as “any and all instances in which communication occurs in two (or more) languages in or around writing” and the continua depict the complex, fluid, and interrelated dimensions of communicative repertoires; it is in the dynamic, rapidly changing and sometimes contested spaces along and across the continua that biliteracy use and learning occur. The continua of biliteracy model was formulated in the context of a multi-year, comparative ethnography of language policy beginning in 1987 in two Philadelphia public schools and their respective communities. It proved useful in analyzing the data and drawing conclusions from the research and by the same token, the ongoing research informed the evolving framework. In the years since it was first proposed, the continua of biliteracy model has informed research locally, nationally, and internationally in Indigenous, immigrant, refugee, heritage, and diaspora language education contexts. Along the way, it has evolved and adapted to accommodate both a changing world and a changing scholarly terrain. Ongoing and future research on the continua of biliteracy addresses trends embedded in the framework and highlighted in this chapter – translanguaging, ecology of language, ethnography of language policy, and ideological and implementational spaces, as instantiated in language education policy and practice in local contexts of Indigenous and ethnic languages and global contexts of diaspora and language spread.

---

N.H. Hornberger (✉)

Graduate School of Education, University of Pennsylvania, Philadelphia, PA, USA

e-mail: [nancyh@upenn.edu](mailto:nancyh@upenn.edu)

---

**Keywords**

Ecology of language • Ethnography of language policy • Implementational and ideological spaces • Indigenous language revitalization • Translanguaging

**Contents**

Introduction .....	126
Early Developments .....	127
Major Contributions .....	130
Global Spread of English .....	131
Indigenous Language Revitalization .....	131
Ethnic, Immigrant, and Heritage Languages .....	132
Diaspora and Linguistic Borderlands .....	133
Problems and Difficulties .....	134
Work in Progress/Future Directions .....	135
Translanguaging and the Continua of Biliteracy .....	135
Ecology of Language and the Continua of Biliteracy .....	136
Ethnography of LPP and the Continua of Biliteracy .....	137
Implementational and Ideological Spaces and the Continua of Biliteracy .....	138
Cross-References .....	139
Related Articles in the Encyclopedia of Language and Education .....	139
References .....	139

---

**Introduction**

The continua of biliteracy model offers an ecological framework in which to situate research, teaching, and language policy and planning in multilingual settings (Hornberger 2003). The original impetus for the model was a multi-year ethnography of language policy in two Philadelphia public schools and their respective Puerto Rican and Cambodian communities – the Literacy in Two Languages (LTL) project beginning in 1987 (Hornberger 1989). A review of research literature on bilingualism and literacy at the time revealed that dimensions commonly characterized by scholars, practitioners, and policymakers as polar opposites, such as first versus second languages (L1 vs. L2), monolingual versus bilingual individuals, or oral versus literate societies, turn out under the scrutiny of research to be only theoretical endpoints on what are in reality fluid and dynamic continua of language and literacy use. Further, as ongoing research in the LTL project and the bilingualism/literacy fields clarified, these continua are interrelated dimensions of highly complex and fluid communicative repertoires (Gumperz 1964; Hymes 1980; Rymes 2010), and it is in the dynamic, rapidly changing and sometimes contested spaces along and across the continua that biliteracy use and learning occur.

Biliteracy is here defined as “any and all instances in which communication occurs in two (or more) languages in or around writing” (Hornberger 1990, p. 213), following from Heath’s definition of literacy events as “occasions in which written language is integral to the nature of participants’ interactions and their interpretive processes and strategies” (Heath 1982, p. 50). This emphasis on

interaction and interpretation around writing contrasts with earlier and contemporary definitions that implicitly or explicitly take bilinguality more narrowly to mean (mastery of) reading (and writing) in two languages (or in a second language) (see Hornberger 2008 for more discussion). Similarly, the emphasis here expands on Heath’s “event” to consider “instances” of bilinguality, including events but also actors, interactions, practices, activities, programs, sites, situations, societies, and worlds (Hornberger 2000).

### Early Developments

These foundational notions are the building blocks for the continua model of bilinguality. The model’s intersecting and nested continua demonstrate the multiple, complex, and fluid interrelationships between bilingualism and literacy and of the contexts, media, and content through which bilinguality develops (schematically represented in Figs. 1, 2, and 3). The model posits that for multilinguals, the *development* of bilinguality occurs “along intersecting first language (L1)-second language (L2), receptive-productive, and oral-written language skills continua; through the *medium* of two (or more) languages and literacies whose linguistic structures vary from similar to dissimilar, whose scripts range from convergent to divergent, and to which the developing bilingual individual’s exposure varies from simultaneous to successive; in *contexts* that encompass micro to macro levels and are characterized by varying mixes along the monolingual-bilingual and oral-literate continua; and . . . with *content* that ranges from majority to minority perspectives and experiences, literary to vernacular styles and genres, and decontextualized to contextualized language texts” (Hornberger 1989; Hornberger and Skilton-Sylvester 2000, p. 96).

The continua of bilinguality incorporate 3 key themes of the ecology of language (cf. Haugen 1972) paralleling the ecology movement more generally – evolution,

**Fig. 1** Nested relationships among the continua of bilinguality (Reprinted with permission from Hornberger and Skilton-Sylvester (2000))

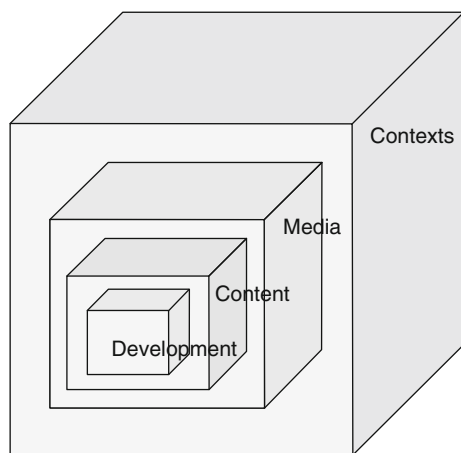

**Fig. 2** Intersecting relationships among the continua of biliteracy (Reprinted with permission from Hornberger and Skilton-Sylvester (2000))

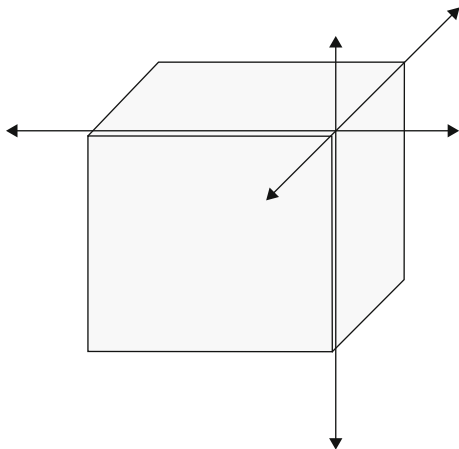

environment, and endangerment. The notion of bi/multiliteracy assumes that one language and literacy is developing in relation to one or more other languages and literacies, i.e., language evolution; the model situates biliteracy development, whether in the individual, classroom, community, or society, in interaction with the contexts, media, and content in and through which it develops, i.e., language environment; and the continua provide a heuristic for addressing the unequal balance of power across languages and literacies in the ecosystem, i.e., for not only researching but also counteracting language endangerment (Hornberger 2002). This ecological framework suggests that the more their contexts of learning and use allow multilinguals to draw from across each and every continuum, the greater are the chances for their full biliterate development and expression. To this end, there is a need to contest hegemonic monolingual, written, decontextualized language and literacy practices in education by intentionally opening up implementational and ideological spaces for fluid, multilingual, oral, contextualized practices and voices at the local level (Hornberger 2002, 2005; Hornberger and Skilton-Sylvester 2000).

As noted above, the continua of biliteracy model was formulated in the context of a multi-year, comparative ethnography of language policy beginning in 1987 in two Philadelphia public schools and their respective communities. Through participant observation, interviewing, and document collection in and out of school in the Puerto Rican community of North Philadelphia and the Cambodian community of West Philadelphia, my students and I sought to understand how national, state, and local policies and programs were interpreted and appropriated in biliteracy attitudes and practices in classroom and community. The continua framework proved useful in analyzing the data and drawing conclusions from our collaborative ethnographic research, and by the same token, the ongoing research informed the evolving framework.

For example, we showed how biliteracy contexts for Puerto Rican and Cambodian students in Philadelphia in the 1980s were framed and constrained by an ecology in which national policies emphasized English acquisition at the expense

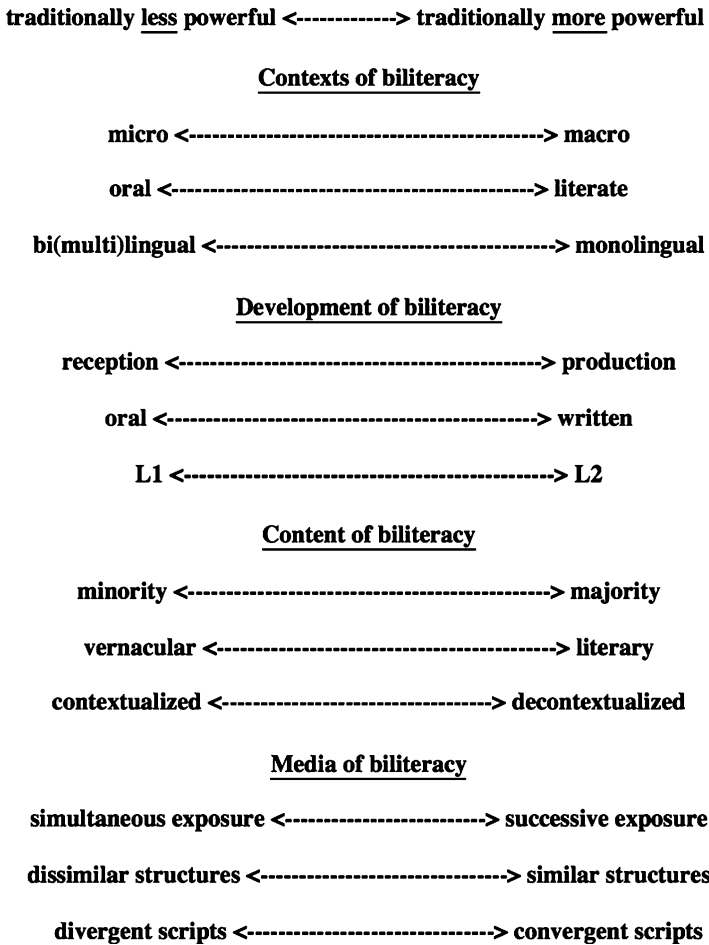

**Fig. 3** Power relations in the continua of bilinguality (Reprinted with permission from Hornberger and Skilton-Sylvester (2000))

of minority language maintenance; the educational system used minority languages only to embed the more powerful English literacy; and the assimilative “charm” of English pulled students’ biliterate development toward English (Hornberger 1992). Our research on adult bilingual development in programs for Puerto Ricans and Cambodians revealed the inadequacy of an autonomous, cognitive skills-based view of literacy with its emphasis on a single, standardized schooled literacy in the L2 and the benefits of an ideological, cultural practice view (Hornberger and Hardman 1994). We documented how faculty and staff in schools serving the Puerto Rican community continually faced challenging decisions related to bilingual media in terms of placement of students in English-dominant and Spanish-dominant streams, distribution of English and Spanish in program structure and classroom, and

instruction and assessment in (a language ecology of) coexisting standard and nonstandard varieties of English and Spanish (Hornberger and Mischeu 1993). Skilton-Sylvester's ethnography of literacy, identity, and educational policy among Cambodian women and girls led to an expansion from the original continua of context, media, and development to include also continua of biliteracy content in order to account for the identities and meanings expressed through biliterate practices and especially the important role of contextualized, vernacular, and minority texts in the women's and girls' biliteracy (Hornberger and Skilton-Sylvester 2000).

---

## Major Contributions

In the years since it was first proposed, the continua of biliteracy model has informed research locally, nationally, and internationally in Indigenous, immigrant, refugee, heritage, and diaspora language education contexts. Along the way, it has evolved and adapted to accommodate both a changing world and a changing scholarly terrain.

In a 2002 paper using the continua as heuristic to consider broad sets of community and classroom challenges faced in implementing transformative multilingual language policies introduced via post-apartheid South Africa's Constitution of 1993 and Bolivia's National Education Reform of 1994, I began by pointing to the twin phenomena of the rise of English as a global language and the reclaiming of endangered Indigenous and ethnic languages at local and national levels as countervailing trends breaking apart the one language – one nation ideology. Drawing on vignettes from my ongoing ethnography of language policy in South African and Andean contexts, I argued that such new multilingual language policies are “essentially about opening up ideological and implementational space in the environment for as many languages as possible, and in particular endangered languages, to evolve and flourish rather than dwindle and disappear” and went on to suggest that “there is urgent need for language educators, language planners, and language users to fill those ideological and implementational spaces as richly and fully as possible before they close in again” (Hornberger 2002, p. 30). Later, comparing the ideological spaces opened up in South Africa and Bolivia with those abruptly closed down in the United States with the enactment of the No Child Left Behind Act in 2002, I suggested that while ideological spaces created by language and education policies can be seen as carving out implementational spaces at classroom and community levels, implementational spaces can also serve reciprocally as wedges to pry open ideological ones as they are being closed down by policy (Hornberger 2005).

The ecology of language metaphor, ethnography of language policy paradigm, and theoretical construct of ideological/implementational space embedded in the continua model have gained scholarly momentum in applied/socio/educational/anthropological linguistics, as exemplified in the studies reviewed in the following paragraphs.



## Global Spread of English

In research on the global spread of English, analysis via the continua of biliteracy has illuminated (challenges to) appropriation of academic biliteracy by French-speaking students in the English-dominant institutional and disciplinary contexts of an English-medium university in Québec province (Gentil 2005); and shed light on why, despite far reaching and progressive goals of bilingual education policies in India, two schools in New Delhi showed marked differences in their success in making students proficient in their second language (Vaish 2008). A group of researchers and educators in the Pacific Islands explored language policy/practice connections in classrooms they characterized as linguistic borderlands, sites where teachers contended every day with postcolonial educational policies designating English the main medium of instruction while children came to school speaking Marshallese, Palauan, or Samoan. Low and colleagues used the continua of biliteracy framework to analyze ideological tensions and paradoxes in teachers' discourses about biliteracy and to call policymakers' attention to the need to create "a dialogic space where community members can query which language(s) should be the medium of instruction and for what purposes" (Low et al. 2004, p. 32).

## Indigenous Language Revitalization

Yet while the spread of English in these and other contexts appears unstoppable, Indigenous language revitalization initiatives and movements burgeon and thrive in the face of seemingly impossible odds. In ongoing work with an early childhood language immersion program launched in 2001 as part of the Cherokee Nation's language and cultural revitalization initiatives, researchers drew on the continua of biliteracy contexts to analyze children's acquisition of literacy in the Cherokee writing system known as "syllabary," including consideration of the unique orthographical, morphological, and lexical features of the language as well as dynamic sociocultural domains of literacy in Cherokee syllabary and differing bilingual language experiences of the Cherokee teachers and their students (Peter and Hirata-Edds 2009). Comparing two studies of young children's emergent biliteracy in home, school, and community contexts – her own study with Spanish-English bilingual children in Arizona and Azuara's (2009) study with Maya-Spanish bilingual children in Yucatán – Reyes (2009) drew on the ecological approach of the continua, finding that "children's acquisition of the dominant and native languages is determined by the functions for which language and literacy are used in specific ecological contexts" (p. 110).

In Indigenous contexts of sociohistorical and sociolinguistic oppression involving Quechua in the South American Andes, Guarani in Paraguay, and Māori in Aotearoa/New Zealand, analysis of contentious educational practices through the continua of biliteracy lens and a Bakhtinian notion of voice suggested that biliterate use of Indigenous children's own or heritage language as medium of instruction

alongside the dominant language may mediate the dialogism, meaning-making, access to wider discourses, and taking of an active stance that are dimensions of voice (Holland and Lave 2001) and that Indigenous voices thus activated can be a powerful force for enhancing the children's own learning and promoting the maintenance and revitalization of their languages (Hornberger 2006). In contexts where topdown regional policies in Apurímac, Peru, have recently opened up ideological spaces for revitalizing Quechua as a unifying regional language, Zavala (2014) found that other layers of the policy process obstruct these spaces due to interpretations by Quechua-speaking civil servants and teachers caught in ideological dilemmas between valuing Quechua as ancestral language useful for interacting with essentialized "pure" Quechua speakers from high-altitude communities and identifying with it as also urban, global, and tied to younger generations and global cultural contact and flows.

In a large-scale study of multilingual literacy among young learners of North Sámi in Sweden, Norway, and Finland, Outakoski (2015) adopted the continua of biliteracy as overarching theoretical framework for analyzing the emergence, development, and media of biliteracy through which Sámi learners expressed their thoughts and ideas. Acknowledging the logic of linguistic power relations and inherent power imbalance that informs the model, she proposed a "practical application" by "mapping" the continua for a particular language community to identify both positive and problematic areas in literacy emergence and develop measures appropriate for addressing different scenarios. This study, like Zavala's above, highlights the challenges and potential of ideological and implementational choices Indigenous language revitalization actors make.

## **Ethnic, Immigrant, and Heritage Languages**

Describing, analyzing, and interpreting language education for ethnic/immigrant/heritage learners in the United States via the continua of biliteracy, ethnographic studies have explored tensions, struggles, and contradictions around the control of biliteracy content in relation to media and context in four rural English-as-a-Second-Language (ESL)/bilingual teachers' classroom practices; portrayed how voices and aspirations of rural Arkansas language minority students were curtailed through ESL classroom practices that weighted the continua toward monolingual English context, majority content, and development through successive exposure to English; and depicted the switch of power hierarchy from English to Korean monolingualism in a church-based Korean heritage language program (Hornberger 2003: chapters by Hardman, Lincoln, Pak, respectively). Affiliated ethnographic studies demonstrated that "pluralist language ideologies and the stance toward ethnicity as separate but shareable contribute to Korean language maintenance ... through facilitating biliteracy development of Korean Americans" (Jeon 2005, p. vii) and illustrated the centrality of ecology and identity in the biliterate development of Chinese heritage languages and their speakers (Wang 2004). Analysis of Chinese complementary schooling in Scotland through the continua lens showed how language

policies shaped children's biliteracy experiences towards learning Mandarin (context), texts were used by teachers to guide children to appreciate Chinese cultural values (content), teachers deviated from traditional practices as they sought to generate interest in learning Chinese literacy (media), and children drew on their biliterate resources to support Chinese learning (development) (Hancock 2014).

Analyzing ideological principles and biases underlying language education policies in France that favor prestigious bilingual education for monolingual learners and neglect the bilingualism of immigrant and minoritized speakers, Hélot 2006 used the continua framework to argue for an ecological approach to policy and practice that would bridge the gap between prestigious and immigrant bilingualism, and she illustrated such practice through a language awareness initiative carried out in a small, rural primary school in a multicultural community in the south of Alsace, where teachers "reversed the relations of power imposed by the curriculum through opening their school to parents and making their classrooms inclusive of all the languages and cultures of their pupils," including the Alsatian dialect, immigrant languages such as Arabic, Turkish, Berber, Serber-Croate, as well as more prestigious languages such as Japanese, Italian, Spanish, Russian, and Chinese. In another study of gaps between language policy and practice for heritage language learners, in this case Hebrew language learners in Mexico City's Jewish Educational Network, Stavans 2011 drew on the "continua within a language ecology frame" to "provide a social as well as an institutional educational analytic framework" (p. 5) in her analysis depicting the shortfalls of current language education policy implementation 'by proxy' and the need to move away from a monolingual Hebrew perspective tied to affiliation with Israel and diaspora Jewish communities to an ecologically based trilingual Hebrew-English-Spanish perspective corresponding to local realities.

## Diaspora and Linguistic Borderlands

The continua framework arose in response to LTL research in diaspora immigrant Latino and refugee Cambodian communities of Philadelphia. LTL ethnographies using the continua of biliteracy analytical lens yielded fine-grained analyses of curricular adaptations and culturally contextualized teaching strategies in bilingual classrooms, for example, description of the ways two elementary teachers taught for children's biliterate development through offering motivation, purpose, text, and interaction (Hornberger 1990). Analyzing Latino students' use of bilingual oral and literacy norms as they developed standard monolingual Spanish and English literacy skills in one bilingual classroom provided insight into how, why, for what purposes, and in which varieties educators might or might not correct student "errors," and examining the teaching of two elementary school bilingual education teachers faced with mandated and scripted curricula demonstrated how they creatively adapted the curricula by drawing on linguistic, cultural, and textual resources in their classrooms to ensure comprehensible instruction, inclusion of community funds of knowledge (Moll et al. 1992), and their students' bilingual/biliterate development (Hornberger 2003: chapters by Cahnmann and Schwinge, respectively).

In linguistic borderlands of the US southwest, the continua of biliteracy has informed analysis and interpretation of Latino students' transactions with narrative texts (Martínez-Roldán and Sayer 2006), of *transfronterizo* literacies in a dual language classroom (de la Piedra and Araujo 2012), of Latino kindergarteners' spontaneous biliteracy (de la Luz Reyes 2012), and of the experiences of bilingual teacher education candidates, including "normalistas" graduated from a Mexican normal school and local paraprofessionals, who shared Latino culture broadly defined but differed in the ecologies of their cultural upbringing and use of vernacular and standard, literary Spanish and English language skills (Hornberger 2003: chapter by Pérez, Flores and Strecker). In the Bronx, New York City, two English teachers at Bronx Community College argue that educational policy and practice force Dominican students to make difficult choices between Spanish and English, home community and host community, local and global affiliations. They contrast this with a continua of biliteracy framework that would point to changes in policy and pedagogy that "would do justice to the educational needs of Dominican students" and serve teachers as a heuristic tool in opening up ideological spaces in the local contexts of classrooms, in turn contributing to changes in the community and society (Utakis and Pita 2005, p. 159).

---

## Problems and Difficulties

The continua model is clearly not a *sine qua non* for researching biliteracy since there is continuing work on biliteracy that does not explicitly draw on the continua model, though it is certainly not incompatible with some ongoing work (e.g., Bialystok 1997; Dworin 2003; Wiese 2004). Nor does the framework lend itself to experimental or survey research, given its roots in ethnography of language policy. It has sometimes been misinterpreted as conveying static, bounded, dichotomized, or essentialized views of language and literacy or as pertaining only to *literacy* or to *bi-lingualism*. However, the model is more often rightly recognized as encompassing fluid, flexible, multimodal, and multilingual communicative repertoires. For example, the pluriliteracies approach proposed by García et al. (2007) emphasizing hybridity of plurilingual literacy practices, continuous interplay of multiple languages, modes of communication and semiotic systems, and awareness of the influence of sociocultural contexts on literacy practices fully acknowledges the approach's congruence with (and debt to) the continua of biliteracy.

While recently burgeoning scholarship in the field of bilingualism on languaging, translanguaging and flexible bilingual pedagogies does not always recognize the ways in which these concepts highlight threads already woven into the continua, much of it does. Writing on the origins of the term translanguaging in Welsh-English bilingual classroom pedagogy, where students deliberately and systematically receive input in one language, e.g., by hearing or reading a lesson or passage, and develop their work output in another, e.g., by discussing, writing, or carrying out an activity, Baker argues that the continua of biliteracy "anticipate and valuably extend the notion of translanguaging" (Hornberger 2003: Chapter by Baker, pp. 82–83);

García and Wei (2014), in their comprehensive treatment of translanguaging as “an approach to the use of language, bilingualism and the education of bilinguals that considers the language practices of bilinguals not as two autonomous language systems as has been traditionally the case, but as one linguistic repertoire with features that have been societally constructed as belonging to two separate languages” (p. 2), note that translanguaging “builds on” the continua “by doing away with the distinctions between the ‘languages’ of bilinguals . . . and thereby offer[ing] a way for students to draw on the diverse aspects of the Hornberger continua” (p. 66). Canagarajah (2011) and Creese and Blackledge (2010) link the continua as theoretical underpinning to and ecological model for the use of multilingual repertoire as a resource in classrooms via translanguaging and flexible bilingual pedagogies, respectively. Similarly, recent intellectual moves beyond traditional models of language proficiency to models of emergent, dynamic bilingualism are seen as rooted in the continua of biliteracy (Schissel 2012) and calls for a shift from monoglossic to heteroglossic ideologies (García 2009) reflect a perspective that “views bilinguals’ languages as interdependent and complementary. . . [and] recognizes that bilingualism and biliteracy exist along continua (Hornberger 1989, 2003; Hornberger and Skilton-Silvester 2000), that children may enter schools at different points on these continua, and that using 1 language in the learning of another is both a natural process and an asset” (Allard et al. 2014, p. 337).

---

## Work in Progress/Future Directions

Ongoing and future research on the continua of biliteracy addresses the trends highlighted above – translanguaging, ecology of language, ethnography of language policy, and ideological and implementational spaces instantiated in language education policy and practice in local contexts of Indigenous and ethnic languages and global contexts of diaspora and language spread, as exemplified below.

## Translanguaging and the Continua of Biliteracy

The US national policy context where standardized tests dominate curriculum and instruction and first language literacy is undervalued poses unusual challenges for learners whose communicative repertoires encompass translanguaging practices. Hornberger and Link (2012) drew on the critical sociolinguistics of globalization, their own ethnographic data, and the continua of biliteracy to point to the glaring need for US schools to offer new spaces for innovative programs, curricula, and practices that recognize, value, and build on the multiple, mobile communicative repertoires and translanguaging practices of students and their families (see also Hornberger 2013). Reyes and Hornberger (2016) also explore how the continua model can help researchers and educators understand and build on translanguaging practices and pedagogies.

In a recent study investigating perceived and expected opportunities and constraints of translanguaging pedagogy in linguistically heterogeneous classrooms carried out via interviews and observations in two newcomer and two international schools in the Netherlands, Ticheloven (2016) inquired into whether translanguaging practices hold as pedagogy, how to design accessible and applicable translanguaging pedagogies for teachers in different contexts, and how the continua of biliteracy might play a role in this; similar research on translanguaging and the continua of biliteracy is underway by a Swedish scholar looking at policy, practice, and theoretical understandings underpinning both mother tongue instruction in Arabic, Kurdish, Urdu, and Turkish in Swedish classrooms and mother tongue speakers assisting recently arrived students with their work in Swedish-medium instruction (Warren, personal communication). I expect there will be more and continuing studies on the relationships between translanguaging and the continua of biliteracy.

### **Ecology of Language and the Continua of Biliteracy**

Canagarajah (2005) emphasized that the continua framework offers an ecological heuristic for considering language policy, and this is certainly exemplified in work reported in Hornberger (2003), for instance chapters by Bloch and Alexander on South Africa and Baker on the Welsh National Curriculum, and similarly by Freeman (2004) on Puerto Rican and other language minority community bilingualism in the United States. In addressing ecological dilemmas confronting bilingual (and language) educators, Hornberger (2004) identified ways the continua framework might shape a response by enabling educators' awareness of the complex ecologies of biliteracy and providing a heuristic for their decision-making in shaping curriculum and classroom practice in relation to global/local contexts for biliteracy, standard/nonstandard varieties as media of biliteracy, language/content in biliteracy development, and teachers' and students' languages/cultures/identities in biliteracy content. Hornberger and Hult (2008) outlined guiding questions for an ecological approach to language planning and policy, illustrating them with two examples: an analysis of the representation of multilingualism across multiple layers of policy text in Sweden, illuminating how a changing European ecology of languages including increased internationalization and the growing presence of English, played a role in both the call to make Swedish an official language and the reaffirmation of multilingualism; and the other showing how language education policies practiced and promoted by the Program for Professional Development in Bilingual Intercultural Education for the Andean Region (PROEIB-Andes) provided both an opening and a wedge for political mobilization and activism of Indigenous language speakers within an ecology of languages that has traditionally excluded Indigenous voices and decision-making.

In an ethnographic/practitioner inquiry into the practices of multimodal literacy with 4th graders learning to perform traditional Japanese storytelling, or kamishibai, in two public schools in northeastern United States, McGowan (2012) turned to the ecological framework of the continua of biliteracy, adapting it from description of

multilingual environments where languages evolve, exist, and possibly become endangered in an ecosystem to interpretation of shifts across (speaking, writing, drawing, and performing) modes that exist and evolve in symbiotic relationships within specific classroom ecologies. Ethnographically exploring the ecology of language (and biliteracy) at a Ukrainian university implementing English as medium of instruction where Ukrainian and Russian were in use, Goodman (2013) sought to understand discourses, day-to-day realities, and classroom practices around English language education as situated in the larger language ecology of the university as well as Ukrainian language policy and goals of economic development and integration with the European Union. In a study of the vitality of local/regional mother tongues vis-à-vis Urdu and English in the language ecology of Pakistan, Manan and David (2014) examined literacy levels of undergraduate students, analyzing questionnaires, interviews, and participant observation via the continua model and found that literacy situations privilege Urdu and English over local mother tongues; academic reading/writing proficiency is higher in Urdu and English than in mother tongues; and greater pragmatic value is attached to academic literacy in Urdu and English while the mother tongues are valued for identity, intra-ethnic interaction, and family chitchat.

### **Ethnography of LPP and the Continua of Biliteracy**

Hornberger and Johnson (2007) introduced the ethnography of language policy as a way to illuminate local interpretation and implementation of language policy and planning (LPP), expose human agency and ingenuity at the local level of implementation, and highlight the opening up and closing down of implementational and ideological spaces, a proposal that has been taken up enthusiastically and promises to continue to be developed (e.g., McCarty 2011; see also McCarty, ► [Ethnography of Language Policy](#), this volume). Ethnographic and discourse analytic study of language policy enables a more complex account of the nature, locations and actors of LPP, and in particular the relationships between structure and agency in the multiple, layered contexts of language policy process and activity. Drawing on the ethnography of LPP to examine data from a 3-year ethnography on Mexican immigrant fathers and their elementary school aged children in a policy context of heightened deportations, Gallo and Hornberger ([forthcoming](#)) reveal unintended language education consequences of immigration policy as well as the complex ways that children discursively contribute to family LP and migration decisions, orienting to monoglossic schooling ideologies as they prepare for and contest the possibilities of transnational schooling in Mexico. Noting how limited opportunities to develop dynamic bilingualism or biliteracy in US schools shape families' decisions, we argue that educational policy and classroom practices that open up ideological and implementational spaces to dynamically develop both languages are needed to better prepare children – especially those from undocumented families within a context of unprecedented deportations – for educational success on both sides of the border.

## **Implementational and Ideological Spaces and the Continua of Biliteracy**

The notion of opening and filling up implementational and ideological spaces for multilingual education was originally inspired by Chick's (2001) suggestion that the emergence of alternative multicultural discourses he observed among teachers in South Africa was enabled by the ideological space opened up by new multilingual language policies. It is fitting, then, that two South African studies demonstrate the use of the continua as heuristic for developing, trying out, and demonstrating workable implementational strategies wedging open these spaces: one implementing multilingual teaching and learning in Xhosa, Afrikaans, and English in a formerly colored primary school in Cape Town (Hornberger 2003: Chapter by Bloch and Alexander) and another implementing curriculum planning and classroom pedagogy in a dual medium English-Sepedi B.A. degree program in Limpopo (Hornberger 2010). The activist and transformative uses to which the continua can be put at individual, classroom, community, and societal levels are highlighted by Freeman (2004), who suggests language planners can use the continua to look closely at the contexts, media, and content of particular individuals' or groups' biliteracy, identifying contradictions between beliefs and practices or discrepancies between ideal policy and actual implementation, and then using those contradictions and discrepancies to further pry open ideological and implementational spaces for biliteracy development. Similarly emphasizing the ways the continua inform both ideological and implementational spaces, the model has been recognized as both explanatory and praxis-oriented (Egbo 2005), as moving beyond a programmatic concern to address instructional needs (Cook-Gumperz 2004), as overarching conceptual tool for teachers in understanding reciprocal roles of language in literacy development and of literacy in language development (Goh and Silver 2006), as schema for understanding and intervention at community, institutional, and social/political levels (Lo Bianco 2004), as guide to policy-making (Luke 2005), and as treating policy for both macro-social educational domains and local life in classrooms seriously (Canagarajah 2005).

Drawing on Hornberger's (2005) ideological and implementational spaces and defining them respectively as the dominant ways of understanding language in local settings and the ways these understandings are enacted in classroom practice, Flores and Schissel (2014) analyze ethnographic data from two Philadelphia bilingual elementary classrooms in terms of the ideological and implementational spaces created by teachers and students in the context of standards-based reforms and show that the reforms are the biggest barrier to creating heteroglossic ideological and implementational spaces. They argue that what is needed is to create both ideological spaces that move away from monoglossic language ideologies and implementational spaces that provide concrete tools for enacting a heteroglossic vision in the classroom. Focusing her analysis on four instances of multilingual policy negotiation in Peru – the Experimental Bilingual Education Project of Puno (PEEB) and the Program of Bilingual and Intercultural Education in the Alto Napo (PEBIAN) of the 1970s and the current Office of Intercultural Bilingual and Rural



Education (Ministry of Education) and Office of Indigenous Language (Ministry of Culture) – Kvietok (2015) explores how different actors have “carved up, filled in and re-imagined ideological and implementational spaces . . . for the promotion of language diversity in Peru” (p. 22). She concludes with a call for “as many actors as possible in as many layers as possible, and in as many processes as possible” to be “engaged in opening up spaces for multiple languages and identities” (p. 37). To the extent that the continua of biliteracy and associated notions of translanguaging, ecology of language, ethnography of language policy, and ideological and implementational spaces contribute to furthering cultural and linguistic diversity in our world through research, policy, and practice, it will be fulfilling the purpose for “imagining” it in the first place.

---

## Cross-References

- ▶ [Critical Ethnography](#)
- ▶ [Ethnography and Language Education](#)
- ▶ [Ethnography of Language Policy](#)
- ▶ [From Researching Translanguaging to Translanguaging Research](#)
- ▶ [Linguistic Ethnography](#)
- ▶ [Researching Historical Perspectives on Language, Education, and Ideology](#)

---

## Related Articles in the Encyclopedia of Language and Education

- Katherine Mortimer: [Discursive Perspectives on Language Policy and Planning](#). In Volume: Discourse and Education
- Nelson Flores and Jeff Bale: [Socio-political Issues in Bilingual Education](#). In Volume: Bilingual Education
- Ofelia García, and Angel M.Y. Lin: [Translanguaging in Bilingual Education](#). In Volume: Bilingual Education
- Taehee Choi: [Identity, Transnationalism and Bilingual Education](#). In Volume: Bilingual Education

---

## References

- Allard, E., Mortimer, K., Gallo, S., Link, H., & Wortham, S. (2014). Immigrant Spanish as liability or asset?: Generational diversity in language ideologies at school. *Journal of Language, Identity, and Education*, 13(5), 335–353.
- Azuara Sánchez, P. (2009). *Literacy practices in a changing cultural context: The literacy development of two Emergent Mayan-Spanish bilingual children*. Doctoral dissertation. Retrieved from ProQuest Dissertations Publishing. (3360174)
- Bialystok, E. (1997). Effects of bilingualism and biliteracy on children’s emerging concepts of print. *Developmental Psychology*, 33, 429–440.

- Canagarajah, A. S. (2005). Accommodating tensions in language-in-education policies: An afterword. In A. Lin & P. Martin (Eds.), *Decolonisation, globalisation: Language-in-education policy and practice* (pp. 194–201). Clevedon: Multilingual Matters.
- Canagarajah, S. (2011). Codemeshing in academic writing: Identifying teachable strategies of translanguaging. *Modern Language Journal*, 95(3), 401–417.
- Chick, J. K. (2001). Constructing a multicultural national identity: South African classrooms as sites of struggle between competing discourses. *Working Papers in Educational Linguistics*, 17(1–2), 27–45.
- Cook-Gumperz, J. (2004). Review of Nancy H. Hornberger (Ed.), *Continua of biliteracy*. *Anthropology and Education Quarterly*, 35(4), 494–495.
- Creese, A., & Blackledge, A. (2010). Translanguaging in the bilingual classroom: A pedagogy for learning and teaching? *Modern Language Journal*, 94, 103–115.
- de la Luz Reyes, M. (2012). Spontaneous biliteracy: Examining Latino students' untapped potential. *Theory into Practice*, 51, 248–255.
- de la Piedra, M. T., & Araujo, B. (2012). Transfronterizo literacies and content in a dual language classroom. *International Journal of Bilingual Education and Bilingualism*, 15(6), 705–721.
- Dworin, J. (2003). Examining children's biliteracy in the classroom. In A. I. Willis, G. E. Garcia, R. B. Barrera, & V. J. Harris (Eds.), *Multicultural issues in literacy research and practice* (pp. 29–48). Mahwah: Lawrence Erlbaum.
- Egbo, B. (2005). Review of Nancy H. Hornberger (Ed.), *Continua of biliteracy*. *International Journal of Bilingual Education and Bilingualism*, 8(1), 84–88.
- Flores, N., & Schissel, J. L. (2014). Dynamic bilingualism as the norm: Envisioning a heteroglossic approach to standards-based reform. *TESOL Quarterly*, 48(3), 454–479.
- Freeman, R. D. (2004). *Building on community bilingualism*. Philadelphia: Caslon Publishing.
- Gallo, S., & Hornberger, N. H. (forthcoming). Immigration policy as family language policy: Mexican immigrant children and families in search of biliteracy. *International Journal of Bilingual Education and Bilingualism*.
- García, O. (2009). *Bilingual education in the 21st century: A global perspective*. Malden: Wiley-Blackwell.
- García, O., & Wei, L. (2014). *Translanguaging: Language, bilingualism and education*. New York: Palgrave Macmillan.
- García, O., Bartlett, L., & Kleifgen, J. A. (2007). From biliteracy to pluriliteracies. In P. Auer & W. Li (Eds.), *Handbook of applied linguistics* (Multilingualism, Vol. 5, pp. 207–228). Berlin: Mouton/de Gruyter.
- Gentil, G. (2005). Commitments to academic biliteracy: Case studies of Francophone university writers. *Written Communication*, 22(4), 421–471.
- Goh, C. C. M., & Silver, R. E. (2006). *Language learning: Home, school, and society*. Singapore: Pearson/Longman.
- Goodman, B. A. (2013). *Towards a multilingual future: The ecology of language at a university in Eastern Ukraine*. Doctoral dissertation. Retrieved from ProQuest Dissertations Publishing (3566442).
- Gumperz, J. J. (1964). Linguistic and social interaction in two communities. *American Anthropologist*, 66(6, part 2), 137–153.
- Hancock, A. (2014). Chinese complementary schools in Scotland and the continua of biliteracy. In X. L. Curdt-Christiansen & A. Hancock (Eds.), *Learning Chinese in diasporic communities: Many pathways to being Chinese* (pp. 59–80). Philadelphia: John Benjamins.
- Haugen, E. (1972). *The ecology of language*. Stanford: Stanford University Press.
- Heath, S. B. (1982). What no bedtime story means: Narrative skills at home and school. *Language in Society*, 11(1), 49–76.
- Hélot, C. (2006). Bridging the gap between prestigious bilingualism and the bilingualism of minorities: Towards an integrated perspective of multilingualism in the French education context. In M. O'Laoire (Ed.), *Multilingualism in educational settings* (pp. 49–72). Tübingen: Stauffenburg Verlag.

- Holland, D., & Lave, J. (Eds.). (2001). *History in person: Enduring struggles, contentious practice, intimate identities*. Santa Fe: School of American Research Press.
- Hornberger, N. H. (1989). Continua of biliteracy. *Review of Educational Research*, 59(3), 271–296.
- Hornberger, N. H. (1990). Creating successful learning contexts for bilingual literacy. *Teachers College Record*, 92(2), 212–229.
- Hornberger, N. H. (1992). Biliteracy contexts, continua, and contrasts: Policy and curriculum for Cambodian and Puerto Rican students in Philadelphia. *Education and Urban Society*, 24(2), 196–211.
- Hornberger, N. H. (2000). Afterword: Multilingual literacies, literacy practices, and the continua of biliteracy. In M. Martin-Jones & K. Jones (Eds.), *Multilingual literacies: Reading and writing different worlds* (pp. 353–367). Philadelphia: John Benjamins.
- Hornberger, N. H. (2002). Multilingual language policies and the continua of biliteracy: An ecological approach. *Language Policy*, 1(1), 27–51.
- Hornberger, N. H. (Ed.). (2003). *Continua of biliteracy: An ecological framework for educational policy, research and practice in multilingual settings* (Bilingual education and bilingualism, Vol. 41). Clevedon: Multilingual Matters.
- Hornberger, N. H. (2004). The continua of biliteracy and the bilingual educator: Educational linguistics in practice. *International Journal of Bilingual Education and Bilingualism*, 7(2–3), 155–171.
- Hornberger, N. H. (2005). Opening and filling up implementational and ideological spaces in heritage language education. *Modern Language Journal*, 89(4), 605–609.
- Hornberger, N. H. (2006). Voice and biliteracy in indigenous language revitalization: Contentious educational practices in Quechua, Guarani, and Māori contexts. *Journal of Language, Identity, and Education*, 5(4), 277–292.
- Hornberger, N. H. (2008). Continua of biliteracy. In A. Creese, P. Martin, & N. H. Hornberger (Eds.), *Encyclopedia of language and education* (Ecology of language 2nd ed., Vol. 9, pp. 275–290). New York: Springer.
- Hornberger, N. H. (2010). Language and education: A Limpopo lens. In N. H. Hornberger & S. L. McKay (Eds.), *Sociolinguistics and language education* (pp. 549–564). Bristol: Multilingual Matters.
- Hornberger, N. H. (2013). Biliteracy continua. In M. R. Hawkins (Ed.), *Framing languages and literacies: Socially situated views and perspectives* (pp. 149–168). New York: Routledge.
- Hornberger, N. H., & Hardman, J. (1994). Literacy as cultural practice and cognitive skill: Biliteracy in a Cambodian adult ESL class and a Puerto Rican GED program. In D. Spener (Ed.), *Adult biliteracy in the United States* (pp. 147–169). Washington, DC: Center for Applied Linguistics.
- Hornberger, N. H., & Hult, F. M. (2008). Ecological language education policy. In B. Spolsky & F. M. Hult (Eds.), *Handbook of educational linguistics* (pp. 280–296). Malden: Blackwell.
- Hornberger, N. H., & Johnson, D. C. (2007). Slicing the onion ethnographically: Layers and spaces in multilingual language education policy and practice. *TESOL Quarterly*, 41(3), 509–532.
- Hornberger, N. H., & Link, H. (2012). Translanguaging and transnational literacies in multilingual classrooms: A biliteracy lens. *International Journal of Bilingual Education and Bilingualism*, 15(3), 261–278.
- Hornberger, N. H., & Micheau, C. (1993). “Getting far enough to like it”: Biliteracy in the middle school. *Peabody Journal of Education*, 69(1), 30–53.
- Hornberger, N. H., & Skilton-Sylvester, E. (2000). Revisiting the continua of biliteracy: International and critical perspectives. *Language and Education: An International Journal*, 14(2), 96–122.
- Hymes, D. H. (1980). *Language in education: Ethnolinguistic essays*. Washington, DC: Center for Applied Linguistics.
- Jeon, M. (2005). *Language ideology, ethnicity, and biliteracy development: A Korean-American perspective*. Doctoral dissertation. Retrieved from ProQuest Dissertations Publishing (3179754).

- Kvietok Dueñas, F. (2015). Negotiating ideological and implementational spaces for Indigenous languages in Peru. *Working Papers in Educational Linguistics*, 30(1), 21–41.
- Lo Bianco, J. (2004). Review of Nancy H. Hornberger (Ed.), *Continua of biliteracy: Language and Education*, 18(4), 336–341.
- Low, M., Penland, D., Ruluked, E., & Sataua, P. (2004). Oral traditions and English: Language policy/practice relations in postcolonial classrooms. *Unpublished manuscript*.
- Luke, A. (2005). Making educational policy with research evidence in ASEAN countries. Address to the ASEAN Directors General of Education, Thai Ministry of Education, August 12.
- Manan, S. A., & David, M. K. (2014). Mapping ecology of literacies in educational setting: The case of local mother tongues vis-à-vis Urdu and English languages in Pakistan. *Language and Education*, 28(3), 203–222.
- Martínez-Roldán, C. M., & Sayer, P. (2006). Reading through linguistic borderlands: Latino students' transactions with narrative texts. *Journal of Early Childhood Literacy*, 6(3), 293–322.
- McCarty, T. L. (Ed.). (2011). *Ethnography and language policy*. New York: Routledge.
- McGowan, T. M. (2012). *Loosening the ligatures of text: Kamishibai performance in the modal ecologies of 21st century classrooms*. Doctoral dissertation. Retrieved from ProQuest Dissertations Publishing (3509210).
- Moll, L., Amanti, C., Neff, D., & Gonzalez, N. (1992). Funds of knowledge for teaching: Using a qualitative approach to connect homes and classrooms. *Theory into Practice*, 31, 132–141.
- Outakoski, H. (2015). *Multilingual literacy among young learners of North Sámi: Context, complexity and writing in Sápmi*. Doctoral dissertation, Umeå University, Umeå. (Umeå Studies in Language and Literature 27).
- Peter, L., & Hirata-Edds, T. (2009). Learning to read and write Cherokee: Toward a theory of literacy revitalization. *Bilingual Research Journal*, 32(2), 207–227.
- Reyes, I. (2009). An ecological perspective on minority and majority language and literacy communities in the Americas. *Colombian Applied Linguistics*, 11, 106–114.
- Reyes, I., & Hornberger, N. H. (2016). Conversation currents: The continua of biliteracy. *Language Arts*, 93(5), 401–406.
- Rymes, B. (2010). Classroom discourse analysis: A focus on communicative repertoires. In N. H. Hornberger & S. L. McKay (Eds.), *Sociolinguistics and language education* (pp. 528–546). Bristol: Multilingual Matters.
- Schissel, J. L. (2012). *The pedagogical practice of test accommodations with emergent bilinguals: Policy-enforced washback in two urban schools*. Doctoral dissertation. Retrieved from ProQuest Dissertations Publishing (3551552).
- Stavans, A. (2011). Language education policy by proxy: The 'ideal' meets the 'real' in the educational network of the Jewish Community in Mexico City. *International Journal of Multilingualism*. doi:10.1080/14790718.2011.588331.
- Ticheloven, A. (2016). *Translanguaging as pedagogy in a superdiversity classroom: Constraints and opportunities*. Master's thesis, Utrecht University, Utrecht.
- Utakis, S., & Pita, M. D. (2005). An educational policy for negotiating transnationalism: The Dominican community in New York City. In A. S. Canagarajah (Ed.), *Reclaiming the local in language policy and practice* (pp. 147–164). Mahwah: Lawrence Erlbaum.
- Vaish, V. (2008). *Biliteracy and globalization: English language education in India*. Clevedon: Multilingual Matters.
- Wang, S. C. (2004). *Biliteracy resource eco-system of intergenerational language and culture transmission: An ethnographic study of a Chinese-American community*. Doctoral dissertation. Retrieved from ProQuest Dissertations Publishing (3152119).
- Wiese, A.-M. (2004). Bilingualism and biliteracy for all?: Unpacking two-way immersion at second grade. *Language and Education*, 18(1), 69–92.
- Zavala, V. (2014). An ancestral language to speak with the "other": Closing down ideological spaces of a language policy in the Peruvian Andes. *Language Policy*, 13(1), 1–20.

---

## Part II

# Language Variation, Acquisition, and Education

---

# Variationist Approaches to Language and Education

Kirk Hazen

---

## Abstract

Scholars of language variation and change have contributed to educational projects since the 1960s. The primary focus has been explaining the nature of dialects and language change to educational practitioners and students. Researchers have made connections to composition and other realms of English studies. Vernacular dialects, such as African-American Vernacular English, have been the main area of research, as these are the dialects that have been least understood and most disparaged. Researchers have attempted to help educational professionals and students better understand the nature of language and specifically language variation in order to improve educational practice.

---

## Keywords

Sociolinguistics • Dialect • AAVE • Labov • Stereotypes

## Contents

Introduction .....	146
Early Developments .....	147
Major Contributions .....	148
Key Positions .....	148
Foundational Work on Nonstandard Dialects, Literacy, and Policies .....	149
Arguments for Nonintervention .....	151
Classroom Solutions .....	151
Teachers and Teachers' Attitudes .....	152
Sociolinguistic Views and Prescriptivist Traditions .....	154

---

K. Hazen (✉)

Department of English, Eberly College of Arts and Sciences, West Virginia University,  
Morgantown, WV, USA

e-mail: [Kirk.Hazen@mail.wvu.edu](mailto:Kirk.Hazen@mail.wvu.edu)

Conclusion: Challenges and Future Directions .....	155
Cross-References .....	155
Related Articles in the Encyclopedia of Language and Education .....	156
References .....	156

---

## Introduction

Since the 1960s, sociolinguists have investigated the interactions of language variation and education. Broadly construed, language variation includes language change as well as social and geographic variation at any one point in time. For the purposes of education, the overwhelming focus has been on socially stigmatized language variation. Since language variation is a daily presence in every classroom, many proactive efforts of variationists have concentrated on how educational policies and practitioners handle language variation.

The study of sociolinguistic variation developed from the fields of linguistics, anthropology, sociology, and social psychology, and therefore it has a wide range of methods and goals (Holmes and Hazen 2014). On the linguistic side, the study of language variation developed from phonology and other linguistic fields with the goal of constructing explanations for how humans produce their socially and linguistically constrained patterns. The study of language variation differs from traditional linguistics in that scholars study the interaction between social and linguistic factors.

Sociolinguists have long argued against the common and widespread belief that there is a single supreme, homogenous correct form, and that all other forms are deficient derivatives of it. Over recent decades, sociolinguists have emphasized that all languages have multiple, linguistically legitimate forms and that correctness is a matter of socially and rhetorically determined genre conventions (Hazen 2015). There are many standard Englishes, and they have been variously defined at different times according to shifting social and linguistic standards: For example, a question in the form of “Ran he this way?” instead of “Did he run this way?” was standard before the 1500s. Along with these standard Englishes are many other linguistically legitimate varieties that do not carry the favored social status that the standard varieties enjoy. In the USA, these stigmatized varieties are most often labeled as *vernacular*.

This chapter focuses specifically on language variation issues and explains important scholarship and possible paths of study as well as practical solutions. This piece covers some early developments of language variation and education, in addition to major contributions (e.g., key positions, foundational work on vernacular varieties and literacy, classroom solutions, and teachers’ and students’ attitudes toward language variation). Lastly, this work touches upon problems and difficulties in language variation study, recent scholarship, and conclusions that point toward possibilities for future study of language variation’s position in educational debates.

## Early Developments

During the 1960s and 1970s, the pervasive question across both public and scholarly debate was what roles nonstandard language should play, if any, in institutional education. In other words, should vernacular language be encouraged, allowed, or discouraged in the classroom? Through this time, sociolinguists sided with two different approaches to language variation and education. In practice, these approaches were not mutually exclusive and were implemented in the same educational practices. The first approach was the dialect rights position from the National Council of Teachers of English, which maintains that students have a right to use their own language variety. The second approach involved the so-called additive dialect model, where standard language features are taught to vernacular speakers. Note that vernacular features are rarely taught to nonvernacular speakers, and criticism of this approach has been pointed at times, as ethnic minorities are required to adjust language features to the white majority's conventions (Sledd 1969). One of the implications for both these approaches is that students can retain their home variety while learning the genre conventions of standard writing. Another important implication is that speakers of nonstigmatized dialects, both students and teachers, should respect the speakers of stigmatized dialects.

The ideas of the dialect rights position have not always been clear for educational professionals, but a recent book helps to clarify the years of debate and to elucidate the fundamental questions. Perryman-Clark et al. (2014) created a critical sourcebook for US educators to draw from retrospective analysis of the past four decades' practical strategies, such as employing multigenre writing to help students explore their fullest range of language variation.

The additive approach follows a metaphor where people possess a "dialect" and then add another one to it, namely, the nonstigmatized standard "dialect." For scholars who study language variation, the term *dialect* works for larger units, such as geographic regions (e.g., the US South). Speakers develop diverse personal styles, which are drawn from language variation patterns of the larger dialect. The additive method attempts to teach students how to recognize stigmatized language variation patterns (e.g., possessive's loss in *That is Marc\_ ball*) and replace them with nonstigmatized alternatives (e.g., *That is Marc's ball*) in the rhetorically appropriate contexts. Successful students in such programs should be able to recognize and perform in several genres. Reaser and Adger (2008) cover the entire range of educational issues concerning vernacular language varieties, including summarizing the largest studies of oral language development with a focus on language variation; they conclude that vernacular varieties do not cause developmental problems for students but institutional responses to the students do cause educational problems.

For both these approaches, educational success is dependent on distinguishing spoken language from written genre conventions.



## Major Contributions

Modern sociolinguistic methodologies were developed from dialectology, linguistics, anthropology, and to some extent sociology (Holmes and Hazen 2014). Researchers from these subfields have made contributions to education from the inception of modern language variation study. Early on in the study of sociolinguistics, researchers recognized that knowledge of different dialects could assist teachers and students in their educational goals.

From this tradition, several modern books provide overviews of how knowledge of language variation, including its history, can benefit educators. These include *We Do Language* (Charity and Mallinson 2014), *Dialects in Schools and Communities* (Adger et al. 2007), and *Linguistics at School* (Denham and Lobeck 2014). These books cover some of the modern understandings of language, such as the recognition that all dialects follow linguistic rules and that language is a natural system that can be examined scientifically. The biggest single step for interested educators would be to learn the basics of how language works, which these texts help elucidate.

For reference sources specifically on vernacular varieties, including African-American English, see the bibliography by Rickford et al. (2012). It provides an excellent overview of the research, including quantitative study, which has been done on vernacular varieties in education. Over time, the focus has shifted from proving the legitimacy of AAVE to helping AAVE speakers learn institutional genre norms. For a general source on language stigmatization in English, such as the use of vernacular varieties in Disney films, readers should consult *English with an Accent* (Lippi-Green 2012).

## Key Positions

In the 1960s, sociolinguists often argued against educational researchers' approaches to language variation in schools, for example, the deficit approach which assumed vernacular speakers were not exposed to enough language as children and hence performed poorly because of underdeveloped verbal skills. Baratz's work (1969) is an important article summarizing three possible stances toward language variation and education. The third approach, the one Baratz champions, is the modern approach of sociolinguists since the late 1960s – namely, that AAVE is a dialect of English like any other dialect of English. Baratz found that African-American children in Washington, DC, did significantly better at accurately repeating AAVE sentences, and European-American children were significantly better at accurately repeating nonstigmatized sentences. The implications from this approach affected language variation study both in speech pathology and in educational fields: The dialect of the community must be evaluated on its own terms. Other countries have experienced similar shifts in public opinion. For example, the UK went through stages of eradicationism, assimilation, tolerance, and acceptance in regard to Black English. These stages resulted from increased knowledge about language variation and its role in stigmatization.

Continuing Baratz's momentum, Fasold and Shuy (1970) edited a volume still valuable for researchers today. Wolfram's contribution in that volume lays out the basics of sociolinguistic research for educational professionals and argues forcefully for granting priority to some teaching goals over others, such as focusing on the most stereotyped features, which are sharply stratified between social classes. Wolfram asserts that doing so helps students learn the contrast between vernacular norms and institutional genre conventions. In addition, Shuy's contribution to the volume cites deprecating quotes from teachers about AAVE and suggests teachers learn about how English varieties work, especially the most stigmatized varieties. Yet, teachers must respect their students' dialects for students to earnestly engage with institutional norms. In a modern work that complements Fasold and Shuy (1970), Alim (2010) suggests how Critical Language Awareness directly addresses the concerns raised by Shuy (1970). Critical language awareness requires speakers to pay attention to the social and political underpinnings of their language ideologies; Alim suggests a classroom activity where students analyze stigmatized patterns (third-person singular verbal – *s* variation) of a local hip-hop artist to understand the systematicity of spoken speech and the sociolinguistic impact. As Shuy noted three decades earlier, Alim discusses how teachers and journalists often carry deep-seated assumptions about AAVE speakers and how traditional approaches to teaching genre conventions are often resisted by AAVE speakers. Critical language awareness helps teachers overcome the frustration associated with the politics of standard language teaching.

Perhaps the most widely known text from this early period of variationist work is Labov's *The Logic of Nonstandard English* (1969), which has both educational and social implications. In this work, Labov explains how the inner workings of non-standard dialects follow clear patterns more consistently than do educated varieties. Claiming that vernacular dialects are legitimate has often been seen as ludicrous by the general public, but for sociolinguistic approaches to be effective, this argument must be faced directly.

## **Foundational Work on Nonstandard Dialects, Literacy, and Policies**

Beyond scholars' engagement with spoken language practice, some linguists envisioned implications for literacy. Labov (1967) discusses the possible interference between students' development of literacy and their dialect, and he has argued that textbook writers and many teachers do not understand enough about the target vernacular varieties to produce truly helpful exercises. For example, the regular past tense form <-ed> is noted to be often absent in AAVE, yet this language variation pattern receives little to no attention from publishers of educational materials (Labov 1967, pp. 157–162).

Creoles have also been a focus of several studies on language variation and education. For example, Carrington (1976) discusses the wide diversity of creoles with different lexifier languages and the subsequent effects on education in the Caribbean territories. He also discusses the proscription of vernacular varieties and

prohibitive attitudes toward nonofficial languages, providing guidelines for determining relationships between vernacular varieties and school policies. For example, the first principal is that linguistic conditions are linguistically favorable to teach in a creole variety if it is unrelated to the official language, but conditions are linguistically unfavorable if the creole is related to the official variety.

In 1979, a legal case involving vernacular varieties and school policies became widely publicized. This case centered on African-American elementary students in Ann Arbor, Michigan, who were segregated into remedial classes. Advocates for the students argued that civil rights were being violated as the students' cultural and linguistic background was not accounted for in planning instruction. The ruling reaffirmed the school's obligation to accommodate their language variation (see Smitherman 2000, p. 154). By the 1990s, the deficit approach was no longer an overt position for educators, and sociolinguists had correspondingly shifted their focus away from proving the linguistic legitimacy of minority varieties.

At the end of 1996, the foundational issues of the difference/deficit debate roared back onto the international stage when the Oakland California School Board took steps to assist their African-American students, many of whom were performing poorly in school. Their approach was to bring students to full literacy by introducing the written word in the style and form of African-American English. For these issues and a full account of the firestorm surrounding the Oakland School Board's activities, readers should consult Rickford and Rickford's *Spoken Soul* (2000).

Similarly, in response to the social furor that eliminated bilingual education in California in 1998, students and professors developed the anthology *Tongue Tied* (Santa Ana 2004). Sociolinguistic approaches are found throughout the volume in application to numerous multilingual situations. For both the Ebonics debate and multilingualism, a safe prediction is that such media-sponsored uproars will occur in the future.

Although these situations are the most widely publicized, nonstandard varieties are not always officially stigmatized. For instance, Norway has two written standards, *Bokmål* and *Nynorsk*, both based on Norwegian speech; the country's law forbids forced speech standardization. This institutional respect for language variation has a long tradition dating back to a parliamentary motion in 1878. The underlying belief is that regional dialects reflect Norwegian cultural tradition uncontaminated by Danish rule. The import for the educational researcher is that stigmatization of nonstandard varieties does not have to be accepted or institutionalized.

As an introduction to sociolinguistic insights on literacy and education in European school systems, Cheshire et al. (1989) provide national perspectives, a review of the literature from 1970 to 1989, and classroom initiatives. For example, one study investigates nonstandard Dutch in school settings: Through examining language tests and both teacher and student questionnaires, they found that nonstandard speakers are at a disadvantage in comparison with their standard-speaking peers. Researchers in Europe have given clear descriptions of the attitudes surrounding more and less standard varieties.

## Arguments for Nonintervention

Complementary to these debates of vernacular dialect in schools, Cheshire (2005) argues that nonstandard varieties in and of themselves are not as “detrimental to educational success as might be thought” (p. 2346). Several previous studies illustrated this point. Williams (1989) found that both standard and nonstandard speakers used colloquial forms in their writing: Hence it is important to analyze written work in order to disambiguate which issues result from normal literacy development and which result from vernacular interference.

The more effective approaches will distinguish the genre conventions of writing. For example, in analyzing three areas of England, Williamson and Hardman (1997, p. 255) advised teachers not to concern themselves with problems of prescriptive grammar and lexical items but to focus on punctuation and orthography. In their study, vernacular forms were rare compared with spelling and punctuation mistakes. This comparison is even true when the students’ spoken language contained more vernacular features.

## Classroom Solutions

Although variationists have identified related problems in educational practice, they have received criticism for not producing solutions. This section highlights some of the potential solutions variationists have discussed.

Rickford and Rickford (1995) examine the role dialect readers can play in classrooms and the benefits they provide for students and teachers. Dialect readers specially developed reading materials that include a local vernacular’s variation in order to encourage literacy. Another important text from this period is Labov (1995), where he proposes five principles which help educational professionals understand the language variation patterns of AAVE. Perhaps the two most important principles are that teachers should (1) distinguish between mistakes in reading and differences in pronunciation and (2) give more attention to the ends of words, as that is the linguistic realm where most differences exist between AAVE and standard varieties. All of Labov’s principles are based on both classroom research and extensive linguistic study of vernacular varieties. Labov and colleagues incorporated these ideas into a tutoring program called the *Reading Road* (<http://www.ling.upenn.edu/pri/>).

Beyond developmental reading issues, research on many levels of language variation should help educational professionals reach their goals with vernacular speakers. Shifting the focus to discourse analysis in educational settings, if educational professionals understand the communicative competence of older students, should bolster their opportunities to be active agents in their education. On numerous linguistic levels, two complementary works provide insights and practical advice for teachers about understanding communicative competence: Denham and Lobeck (2005) and Wheeler and Swords (2006). These works justify the need for modern

grammar study and include sections on classroom methodology and linguistic influences on writing.

In the first program to fully account for language variation across an entire state, Reaser and Wolfram (2005) developed a robust language variation module for middle school social studies classes. Their 450 instructional minute, multimedia curriculum on language diversity in North Carolina can be taught effectively by classroom teachers who have no training in linguistics. In addition, Reaser and Wolfram have also developed other educational resources from their extensive scholarship with language variation: [www.ncsu.edu/linguistics/dialecteducation.php](http://www.ncsu.edu/linguistics/dialecteducation.php).

Focusing on pidgins and creoles, Siegel (2001) developed categories of programs and evaluated their qualities. His categories of programs – instrumental, accommodation, and awareness – incorporate pidgins and creoles to different extents. He further notes that research on instrumental programs, where the home variety is used as the main medium of instruction, in Australia and the Seychelles “has shown that students educated bilingually in their creole mother tongue and the standard outperformed students educated in only the standard language” (2001, p. 748). Siegel attributes the positive benefits of these and other studies to both educational logistics (e.g., students find it easier to develop literacy in familiar varieties first) and to the more positive attitudes such programs engender.

Educational researchers have also adopted variationist approaches to develop solutions to pedagogical problems. For example, Craig and Washington (2006) address long-standing variationist questions: The general consensus of researchers is that AAVE speakers do not have reading comprehension troubles related to their dialect and that no single language variation pattern will explain the black-white achievement gap, especially in terms of literacy.

## Teachers and Teachers’ Attitudes

Several variationist researchers have evaluated teachers’ attitudes toward vernacular speakers. In general, studies have found that teachers in recent decades generally have a more positive attitude about AAVE and minority dialects. This positive support of local dialects is important because several sociolinguistic studies have shown a strong correlation exists between students’ academic success and their community or ethnic identities, both of which influence their speech (e.g., Haig and Oliver 2003).

Teacher and student attitudes are considered the fulcrum of disadvantages for vernacular speakers by Barbour and Stevenson (1990) in their study of German variation. They find that German-speaking Swiss schools, where traditional, non-standard dialects are normal, do not note educational dialect problems; the schools reporting such issues were the ones where vernacular and nonvernacular speakers interact: “. . . this strongly suggests that the problem is overwhelmingly one of social attitudes, rather than of the linguistic characteristics of non-standard German”

(p. 191). Correspondingly, Cheshire and Trudgill (1989) write: “The greatest dialect-related problems in the United Kingdom . . . continue to be the attitudes and prejudices that many people hold towards non-standard dialects and accents of English, combined with the lack of understanding about the nature of dialect differences and of their social significance” (p. 106). As a complement to this view, Cameron (1995) provides a reexamination of linguists’ descriptivist stance in relation to education and details educational reforms in the UK.

Rampton (2006) presents an updated argument about attitudes for English schools. In responding to the work of Trudgill in the 1970s, which propagated the idea of respecting nonstandard dialects, Rampton argued that the same dialect prejudices do not persist in the new century and that the nonstandard-speaking students may not be as linguistically insecure as previously thought (p. 318). In this new context, English teachers face a dilemma: They must both persist as “guardians of grammar” and as “agents of social language reform” and may run up against thorny issues such as third-person singular generic pronouns. Younger teachers might implement nonsexist pronouns rather than perpetuating the grammatical tradition of “generic” he. Importantly, attitudes for students and teachers have to be a recognized part of the curriculum. Cheshire (2005) writes: “The research indicates, then, that educational programmes that recognise the associations that standard and nonstandard English have for speakers, and that build on these, are more likely to result in children becoming proficient in using standard English than are policies which assume that acquiring the standard language is simply a matter of substituting one variant for another” (p. 2349).

Teacher’s reception of language variation is directly related to the teacher’s linguistic awareness. Two dissertations have specifically focused on how low levels of linguistic awareness lead to ineffective teaching. Williams (2012) surveyed composition teachers’ language awareness and then tracked their interactions and discussions of students, specifically one-on-one writing conferences and the instructors’ handling of language variation. Williams concluded better knowledge of the linguistic details of students’ varieties results in better instruction. Strickling (2012) examined how teachers implement the professional development training on language variation that they had received and the subsequent effects on their linguistic awareness.

Beyond attitudes, the variationist research methodology now includes a direct assessment of students’ language abilities. Charity et al. (2004) quantitatively assessed the frequency of standard variants in specified tasks. They distinguished AAVE and school English (SE) by degree of features, not categorical presence or absence. Their scholarly approach includes the position that the level of AAVE language variation patterns is not the important factor in predicting reading failure but instead that the familiarity with SE is the crucial factor. They write: “how often the SE forms are reproduced, was thus chosen as our measure of children’s familiarity with SE” (p. 1342). They also find that “individual differences in familiarity with [school English] are strongly related to reading achievement in young, African-American students” (p. 1354). Their study inverts the reading conundrum by focusing on knowledge of school English.

Around the world and in the USA, the future of variationist research into language and education is bright. Although educational concerns were secondary to variationists in the past, the newest generation of scholars is making them a primary focus. Several dissertations focusing on different educational components highlight the range of research conducted by those attuned to language variation, including the previously mentioned Williams (2012). Sweetland (2006) discusses the study of the development and implementation of language variation teacher training programs. Reaser (2006) examines dialect awareness programs and their effects on teachers' and students' attitudes about language variation. Prichard (2015) assesses the effects of higher education on language variation patterns. Considering the expanded enrollment post-secondary schools have enjoyed since the end of World War II, scholars have learned little about how the experience and the social identity of post-secondary education can affect language variation patterns. Prichard's dissertation provides much needed research about higher education's role in language change.

The potential for expansion of sociolinguistic insights into the language variation of vernacular varieties should also help educational goals outside the English classroom. Mallinson and Charity-Hudley (2014) explore what hurdles speakers of vernacular varieties face in STEM disciplines and the best ways sociolinguists and STEM educators can collaborate to help those students.

---

## Sociolinguistic Views and Prescriptivist Traditions

For educational professionals to confidently adopt a modern view of language variation, they should understand how it contrasts with traditional ideas about how language works and how it can aid their own pedagogical goals. Common beliefs about language are undergirded by several modern myths. One basic myth is that a supremely correct form, without variation, exists for all contexts and times; in previous centuries, this belief extended to the superiority of some languages (e.g., Latin) over others. Today, Western societies are currently in transition from such traditional beliefs to a scientific understanding of how language works.

Two signs of this transformation have become obvious to linguists who interact regularly with public opinion: People more readily accept that no one language is inherently superior and that language change is not decay. Were the other tenets of sociolinguists' findings to be taken up, such as the legitimacy of language variation, the educational goals of literacy and writing would be accomplished more thoroughly and efficiently.

Traditional beliefs about language do not allow any kind of legitimate language variation. Many prescriptivist doctrines of today were established in the eighteenth century, often in erroneous but well-intentioned comparisons between English and Latin. For example, do not split infinitives (e.g., *to boldly go*) and do not strand prepositions (e.g., *We have much to be thankful for*) are both erroneous extensions from Latin to English.

The challenge for scholars of language variation is to demonstrate that traditional prescriptivist approaches are less effective and efficient at achieving institutional goals. Fine-grained, quantitative examinations of pedagogy would provide evidence that a sociolinguistic understanding of language produces the best results. Within students' written and spoken language variation is a wealth of learning opportunities; if educational researchers can construct an accurate model of what students do when they accomplish institutional goals, the modern view of language variation would be an integral part of that process.

The sociolinguistic goals for education are to help people understand the natural linguistic equality of all varieties and help them establish teaching tactics that incorporate a scientifically sound view of language. The new foundation for educational purposes must eschew several components of traditional prescriptivism. This scientifically informed approach would allow teachers to encourage literacy and rhetorical skills at all levels while accurately portraying language. Teaching with an assumption of rhetorically focused language will be more successful for students and teachers alike because of its harmony with the nature of language (Hazen 2015, Chap. 10).

---

## Conclusion: Challenges and Future Directions

For over 50 years, sociolinguists have contributed to language education research and practice. Research on language variation should play an important role in the development of language education policies and programs surrounding nonstandard dialects in education. Researchers have learned over the last half-century about sociolinguistic attitudes and the inner workings of stigmatized varieties. In the next 50 years, they should inquire about the best methods for shifting attitudes to a modern understanding of language variation. The most general results of the language variation approach to language and education should include a better understanding of language use in society and thus students' increased awareness of their own language variation.

One crucial component is to work with teachers to develop materials that reflect a modern, scientific view of language. Understanding how language works, including its social intricacies, makes the teaching of educational genre conventions less of a social hand grenade, increasing both the efficiency and effectiveness of the teaching. When language variation is properly understood, students are less opposed to institutional goals and the social connotations of them.

---

## Cross-References

- ▶ [Language Teacher Research Methods](#)
- ▶ [Researching Identity in Language and Education](#)
- ▶ [Researching the Language of Race and Racism in Education](#)
- ▶ [Second Language Acquisition and Identity](#)
- ▶ [Social Class in Language in Education Research](#)



## Related Articles in the Encyclopedia of Language and Education

- James Collins and Ben Rampton: [Language, Class, and Education](#). In Volume: Language Policy and Political Issues in Education
- Bonny Norton: [Language and Social Identity](#). In Volume: Language Policy and Political Issues in Education

---

## References

- Adger, C. T., Wolfram, W., & Christian, D. (2007). *Dialects in schools and communities* (2nd ed.). Mahwah: Lawrence Erlbaum.
- Alim, H. S. (2010). Critical language awareness. In N. Hornberger & S. McKay (Eds.), *Sociolinguistics and language education* (pp. 205–231). Bristol: Multilingual Matters.
- Baratz, J. C. (1969). A bidialectal task for determining language proficiency in economically disadvantaged Negro children. *Child Development*, 40(3), 889–901.
- Barbour, S., & Stevenson, P. (1990). *Variation in German*. New York: Cambridge University Press.
- Cameron, D. (1995). *Verbal hygiene*. New York: Routledge.
- Carrington, L. (1976). Determining language education policy in Caribbean sociolinguistic complexes. *International Journal of Sociology of Language*, 8, 27–44.
- Charity, A. H., & Mallinson, C. (2014). *We do language: English language variation in the secondary English classroom*. New York: Teachers College Press.
- Charity, A. H., Scarborough, H. S., & Griffin, D. M. (2004). Familiarity with school English in African-American children and its relation to early reading achievement. *Child Development*, 75(5), 1340–1356.
- Cheshire, J. (2005). Sociolinguistics and mother-tongue education. In U. Ammon, N. Dittmar, K. Mattheier, & P. Trudgill (Eds.), *Sociolinguistics: An introductory handbook of the science of language and society* (2nd ed., pp. 2341–2350). London: Mouton de Gruyter.
- Cheshire, J., Edwards, V., Münstermann, H., & Weltens, B. (Eds.). (1989). *Dialect and education: Some European perspectives*. Philadelphia: Multilingual Matters.
- Cheshire, J., & Trudgill, P. (1989). Dialect and education in the United Kingdom. In J. Cheshire, V. Edwards, H. Münstermann, & B. Weltens (Eds.), *Dialect and education: Some European Perspectives* (pp. 94–112). Philadelphia: Multilingual Matters.
- Craig, H. K., & Washington, J. A. (2006). *Malik goes to school: Examining the language skills of African-American students from preschool-5th grade*. Mahwah: Lawrence Erlbaum.
- Denham, K., & Lobeck, A. (Eds.). (2005). *Language in the schools*. Mahwah: Lawrence Erlbaum.
- Denham, K., & Lobeck, A. (Eds.). (2014). *Linguistics at school: Language awareness in primary and secondary education*. New York: Cambridge University Press.
- Fasold, R. W., & Shuy, R. W. (Eds.). (1970). *Teaching standard English in the inner city*. Washington, DC: Center for Applied Linguistics.
- Haig, Y., & Oliver, R. (2003). Language variation and education: Teachers' perceptions. *Language and Education*, 17(4), 266–280.
- Hazen, K. (2015). *An introduction to language*. Malden: Wiley Blackwell.
- Holmes, J., & Hazen, K. (Eds.). (2014). *Research methods in sociolinguistics*. Malden: Wiley Blackwell.
- Labov, W. (1967). Some sources of reading problems for speakers of the Black English vernacular. In A. Frazier (Ed.), *New directions in elementary English* (pp. 140–167). Champaign: National Council of Teachers of English.

- Labov, W. (1969). The logic of nonstandard English. In J. Altai (Ed.), *Georgetown monograph series on language and linguistics* (Vol. 22, pp. 1–44). Washington, DC: Georgetown University Press.
- Labov, W. (1995). Can reading failure be reversed: A linguistic approach to the question. In G. Vivian & D. A. Wagner (Eds.), *Literacy among African-American youth* (pp. 39–68). Cresskill: Hampton Press.
- Lippi-Green, R. (2012). *English with an accent* (2nd ed.). New York: Routledge.
- Mallinson, C., & Charity Hudley, A. H. (2014). Partnering through science: Developing linguistic insight to address educational inequality for culturally and linguistically diverse students in US STEM education. *Language and Linguistics Compass*, 8(1), 11–23.
- Perryman-Clark, S., Kirkland, D. E., & Jackson, A. (2014). *Students' right to their own language*. New York: Bedford St. Martins.
- Prichard, H. (2015). *The role of higher education in linguistic change*. Unpublished doctoral dissertation, University of Pennsylvania, Philadelphia.
- Rampton, B. (2006). *Language in late modernity*. New York: Cambridge University Press.
- Reaser, J. (2006). *The effect of dialect awareness on adolescent knowledge and attitudes*. Doctoral dissertation. Retrieved from UMI Dissertation Publishing. (3264028).
- Reaser, J., & Adger, C. T. (2008). Vernacular language varieties. In B. Spolsky & F. M. Hult (Eds.), *The handbook of educational linguistics* (pp. 161–173). Malden: Blackwell.
- Reaser, J., & Wolfram, W. (2005). *Voices of North Carolina: Language and life from the Atlantic to the Appalachians*. Raleigh: NSCU Press.
- Rickford, J. R., & Rickford, A. E. (1995). Dialect readers revisited. *Linguistics and Education*, 7, 107–128.
- Rickford, J. R., & Rickford, R. J. (2000). *Spoken soul: The story of Black English*. New York: Wiley.
- Rickford, J. R., Sweetland, J., Rickford, A. E., & Grano, T. (2012). *African-American, Creoles and other English Vernaculars in education: A bibliographical resource*. New York: Taylor and Francis/Routledge and National Council of Teachers of English.
- Santa Ana, O. (Ed.). (2004). *Tongue tied: The lives of multilingual children in public education*. Oxford: Rowman and Littlefield.
- Siegel, J. (2001). Pidgins, creoles, and minority dialect in education. In R. Mesthrie (Ed.), *Concise encyclopedia of sociolinguistics* (pp. 747–749). Oxford: Elsevier.
- Sledd, J. (1969). Bidialectalism: The linguistics of white supremacy. *English Journal*, 58, 1307–1329.
- Smitherman, G. (2000). *Talkin that talk: Language, culture, and education in African America*. New York: Routledge.
- Strickling, L. R. (2012). *"This whole language variation journey": Examining teachers' changing beliefs about language and linguistically aware pedagogical applications*. Doctoral dissertation. Retrieved from UMI Dissertation Publishing. (3516253).
- Sweetland, J. (2006). *Teaching writing in the African-American classroom: A sociolinguistic approach*. Doctoral dissertation. Retrieved from UMI Dissertation Publishing. (3235360).
- Wheeler, R. S., & Swords, R. (2006). *Code-switching: Teaching standard English in urban classrooms*. Urbana: National Council of Teachers of English.
- Williams, A. (1989). Dialect in school written work. In J. Cheshire, V. Edwards, H. Münstermann, & B. Weltens (Eds.), *Dialect and education: Some European perspectives* (pp. 182–189). Philadelphia: Multilingual Matters.
- Williams, K. C. (2012). *The role of instructors' sociolinguistic language awareness in college writing courses: A discourse analytic/ethnographic approach*. Doctoral dissertation. Retrieved from UMI Dissertation Publishing. (3504163).
- Williamson, J., & Hardman, F. (1997). To purify the dialect of the tribe: Children's use of nonstandard dialect grammar in writing. *Educational Studies*, 23(2), 157–168.

---

# Social Class in Language in Education Research

David Block

---

## Abstract

Social class has always been a key mediating factor for access to and performance in education, even if the attention it has received has varied: in some cases, it has been minimal, and in other cases, the construct has suffered a kind of *erasure* (i.e., it has disappeared from the lexicon of researchers). The trend toward the latter has been particularly pronounced in research in language education. This chapter takes on the task of discussing research on language and social class in education. After briefly clarifying what we might mean by social class and what it entails, the chapter first covers early developments in class-based language in education research, before moving on to consider, in order, major contributions, work in progress, problems, and difficulties, and finally, future directions in this area. The aim is to provide the reader with a flavor of past, present, and future work in this all-important corner of language in education research.

---

## Keywords

Social class • Language education • Political economy • Marxist thought • Recognition and redistribution

## Contents

Introduction .....	160
Early Developments .....	161
Major Recent Contributions .....	164
Problems and Difficulties .....	165
Future Directions .....	167

---

D. Block (✉)  
ICREA/University of Lleida, Lleida, Spain  
e-mail: [dblock@dal.udl.cat](mailto:dblock@dal.udl.cat)

Cross-References .....	167
Related Articles in the Encyclopedia of Language and Education .....	168
References .....	168

---

## Introduction

In their oft-cited book, *Schooling in Capitalist America*, Bowles and Gintis (1976) wrote about the ways in which educational systems in capitalist societies shape and prepare individuals for their class-based positions in these societies in the following way:

[S]chooling fosters and rewards the development of certain capacities and the expression of certain needs, while thwarting and penalising others. . . . [It] tailors the self-concepts, aspirations, and social class identifications of individuals to requirements of the social division of labor. (p. 129)

Indeed, what the authors wrote here is something of a fundamental truth about the function of education in capitalist societies, and it is one that can be found in the work of key authors who have critiqued capitalism. Thus, while Marx (1990) condemned the denial of education to child factory workers in nineteenth-century England as a way of keeping the proletariat in its place, Gramsci (1971) discussed the division in Italian education in the early twentieth century between “the vocational school for the instrumentalist classes . . . [and] the classical school for the dominant classes and the intellectuals” (p. 26). Such a division in education, which in effect became a powerful force in the reproduction of established class relations in twentieth-century societies, is the center-point of critiques of education in the 1970s and 1980s in contexts such as France (Bourdieu 1984), the USA (Apple 1982), and the UK (Young 1971). Meanwhile, the entire notion of one type of school for the powerful (and some sections of the middle class), and another type of school for the remainder of the population, is a constant in more recent studies of social class in education in the twenty-first century in countries such as China (Sheng 2014), Japan (Kiriya 2013), India (LaDousa 2014), the USA (Weis et al. 2014), and the UK (Reay et al. 2011).

The majority of social class scholars today follow a line of thought through Weber (1968) and Bourdieu (1984) and have developed what I have termed a *constellation-of-dimensions* approach (Block 2015). Following this approach, researchers see an individual’s class position in society as ever-evolving and comprised of one one’s economic resources (e.g., income, wealth, property, material possessions), social resources (occupation, education, prestige, social networking), behavior (consumption patterns, pass times; symbolic presentation of self), and life conditions (type of dwelling, type of neighborhood, quality of life, mobility, physical health). However, it should be noted that these different dimensions are interrelated rather than freestanding and that it is not just matter of slotting people into class categories based on the itemization of each one. In addition, class is a relational phenomenon

which arises when individuals and groups interact in the course of their engagement in social activity. And, as an historical phenomenon, it should not be seen as “a ‘structure’, nor even as a ‘category’, but as something which in fact happens (and can be shown to have happened) in human relationships” (Thompson 1980, p. 8). Finally, it is worth framing any discussion of class in terms of Marx’s (1988) distinction between *class in itself* and *class for itself*, where the former refers to the real, lived class experiences of people such as their work conditions, standard of living, financial situation, spatial relations, and life chances, while the latter refers to what is in essence, class consciousness’ or people’s subjective understandings of their living conditions, their interests, and how they engage in class-based behavior.

With this understanding of social class in mind, I take on the task of discussing research on language and social class in education. First, I discuss early developments in class-based research before moving on to consider, in order, major recent contributions, problems and difficulties, and future directions. Given space restrictions, my coverage of this topic will be selective and partial. However, my aim is to provide the reader with a flavor of past, present, and future work in this all-important corner of language in education research.<sup>1</sup>

---

## Early Developments

Labov (1966) is a good starting point for any review of research on the relationship between language and class. Via questionnaires, he established the class positions of his informants in terms of education, occupation, and income, before considering how the uses of particular features of spoken English (morphological, syntactic, lexical, and, above all, phonetic) index class positions. Labov’s work was in fact about language in society in general, and not specifically education, but his findings have always had implications for language education, not least because the language ideologies which undergird judgments made about language use outside of educational contexts also govern judgments made about language use within language education.

More directly relevant to the field of language education was Bernstein’s (1971) work on class in Britain, which emerged roughly in parallel with Labov’s research. Bernstein’s starting point was social structures in society, and he argued that particular language practices not only contribute to the constitution of these structures, but they also mediate the maintenance, reproduction, and strengthening of them in education. A major element of Bernstein’s thinking about class was a theory of language socialization; he posited that different types of family and different types of codes used by individuals and collectives served as reproductive mechanisms for class hierarchies. These family types were the idealized extremes: “position oriented” and “person oriented.” The former family type lived in smaller dwellings and functioned according to clear and well-defined notions of authority and social roles.

---

<sup>1</sup>NB From this point onwards, I use the word “class” to refer to “social class” for stylistic reasons.

Meanwhile, the latter family type lived in larger dwellings, with more individual and personal space, and functioned more according to dialogue and respect for the individual than authority and clear roles. The former family type was seen as prototypically working class, while the latter was prototypically middle class.

Emerging in such family environments and a range of social contexts were different ways of using language. Here Bernstein posited two general codes, once again as idealized opposites. “Restricted code” was associated with working-class families and their children and entailed a lack of affiliation to institutionalized discourses of education. In turn, “elaborated code” was associated with middle-class families and their children and entailed an affiliation to the institutionalized discourses of education. When children go to school, however, they encounter what Bernstein (1975) calls the “three main message systems” which structure most activity (curriculum, pedagogy, and evaluation): “[c]urriculum defines what counts as a valid knowledge, pedagogy defines what counts as a valid transmission of knowledge, and evaluation defines what counts as a valid realization of this knowledge” (p. 85). Through these three message systems, a class-based culture is shaped around particular ways of framing thinking about the world, particular patterns of acceptable and legitimized behavior, and a value system, derived from curriculum, pedagogy, and evaluation, respectively. When Bernstein’s work first appeared, there was a great deal of controversy around the notions of restricted and elaborated codes, with Labov, Bourdieu, and many others taking issue with what they saw as a “deficit theory” (Labov 1972) or even the “fetichization” of middle-class language use patterns (Bourdieu 1991, p. 53). Nevertheless, as Bernstein (1990) himself tried to explain, “the code theory accepts neither a deficit nor a difference position but draws attention to the relations between macro power relations and micro practices of transmission, acquisition and evaluation and the positioning and oppositioning to which these practices give rise” (pp. 118–119).

Relevant to this chapter is how Bernstein operated as researcher, and here deficiencies in his work are far clearer. Indeed, Rampton, a sympathetic reader of Bernstein, describes him as “emphatically non-ethnographic” (Rampton 2010, p. 7). In essence, Bernstein’s forte was high-level theorizing, and fieldwork was not an integral part of his work. For the latter, we need to move to educational anthropology and examine two paradigmatic studies by Heath (1983) and Eckert (1989). Heath compared and contrasted the language socialization practices of the residents of two communities in the southeastern part of the USA in the 1970s: Roadville residents were white people who for generations had worked in the mills and constituted an upwardly mobile working class; Trackton residents were African-Americans who were new to the mills, having worked previously in agriculture, and who constituted something of an emergent, though still inchoate, working-class community. Heath makes mention of this intra-working-class difference, as well as references to the practices of “townspeople,” who were the more established middle-class local elite. Although a full-blown class-based analysis is never developed in Heath’s research (issues around race and ethnicity were far more central), her work still advanced our

understanding of class differences in language/education given that many of the socialization process she documented may be seen as class-based and not just racially/ethnically based (e.g., how the upwardly mobile white working-class parents adopted more paradigmatically middle-class language socialization patterns than the African-American working-class parents).

Meanwhile, Eckert documented the social and linguistic practices of white middle-class and working-class students attending a suburban Detroit secondary school in the 1980s. She outlined in detail how two adolescent identities were predominant in the school: the “burnouts,” who “came from . . . working class home[s], enrolled primarily in general and vocational courses, smoked tobacco and pot, took chemicals, drank beer and hard liquor, skipped classes, and may have had occasional run-ins with the police,” and the “jocks,” who were “middle class and college bound, played sports for the school, participated in school activities, got respectable grades, and drank beer on weekends” (Eckert 1989, p. 3). Ultimately, the jocks were more cooperative and aligned themselves to the school culture, while the burnouts maintained an adversarial relationship with school culture and in essence opted out of it. Similar to Heath, Eckert does not provide as much class-based analysis as she might have done. Still, her research does advance the notion that schools are sites of class reproduction in societies and the mechanisms therein.

Of interest here is the way that the two authors carried out their research. First of all, both were accomplished ethnographers who adopted a range of data collection techniques from anthropology and other social sciences. Both passed long periods of time embedded in their research contexts (Heath for some 9 years, from 1969 to 1978), as they observed behavior and took field notes, carried out a range of different types of interviews with informants, and collected speech samples in a variety of contexts, both in school and outside school. Heath (1983) notes how research in education up to the 1970s had tended to be “quantitative, global, sociodemographic, and dependent on large-scale comparisons of many schools” (p. 8). What she proposed instead was a form of deep ethnography, which saw her not only collecting data but establishing long-lasting relationships with her informants as she participated in their day-to-day activities. The aim was the documentation and study of “social life as and where it is lived through the medium of a particular social group” (Heath 1983, p. 9). Meanwhile, Eckert advanced the variationist tradition begun by Labov (op. cit.), examining how “the meaning of variation lies in its role in the construction of styles,” which entails “not simply placing variables in styles, but in understanding this placement as an integral part of the construction of social meaning” (Eckert 2003, p. 43). The work of Heath, Eckert, and others who followed them set a certain standard for language education research in general, as well as for research focusing on class. In the next section, I examine how a research agenda organized around class has continued to exist since Labov, Bernstein, Heath, and Eckert, albeit sporadically and not always with a great deal of attention to exactly what is meant by class and class relations in society.

## Major Recent Contributions

In the late 1990s, Rampton (2006) set out to describe and analyze the communicative activity of London secondary school students, both in and out of school. He recorded students in a range of contexts, the classroom being the most typical, and he analyzed the English they spoke. This English was what Cheshire et al. (2011) have recently termed call “Multicultural London English,” that is, an English spoken in London which embodies a series of identifiable features from traditional Cockney and the Englishes spoken in the Caribbean, South Asia, and the USA. Rampton focused on the Cockney features in his informants’ speech, particularly when these were produced in an exaggerated manner. He contrasted what he saw as both natural and performed Cockney with performed “posh” English, where the latter refers to any English that young people see as institutional and middle class (e.g., the language of education). Ultimately, the different ways of speaking English may be seen as *enregistered voices* in that “they index stereotypic social personae” and “social formations in the sense that some language users but not others are socialized in their use and construal” (Agha 2005, pp. 39–49). However, the indexing of “posh” as the *other* in the speech of these young people does not mean that they manifested a strong sense of class consciousness in their day-to-day discourse and activity. Indeed, Rampton found that they seldom explicitly positioned themselves in class terms and that their public constructions of their identities tended to be mediated by notions of race, ethnicity, and gender.

While Rampton’s work is primarily about the linguistic resources of his informants, he also situates himself in a broader movement in sociolinguistics research away from a focus exclusively on the linguistic, to a focus on multimodal repertoires. Such a move entails a consideration of “the set of resources that a speaker actually commands rather than . . . abstract linguistic models” (Snell 2013, p. 115). Eckert’s research (op. cit.) was trendsetting in this regard as she situated variation within style and style as central to communication. More recently, she has emphasized that “variables do not come into a style with a specific, fixed meaning, but take on such meaning in the process of construction of the style” (Eckert 2003, p. 43). Elsewhere, Coupland (2007) defines style as “a way of doing something” (p. 1), which involves the deployment of a range of semiotic resources to achieve the indexical effect of an *enregistered voice*. A related term, stylization, refers to the “reflexive communicative action in which speakers produce specially marked and often exaggerated representations of languages, dialects, accents, registers or styles that lie outside their habitual repertoire” (Rampton 2011, p. 3). Meanwhile, stance is understood as “a person’s expression of their relationship to their talk (their epistemic stance – e.g., how certain they are about their assertions), and a person’s expression of their relationship to their interlocutors (their interpersonal stance – e.g., friendly or dominating)” (Kiesling 2009, p. 172).

Snell (2013) provides good working examples of how this amalgam of constructs comes together as she examines linguistic variation, multimodal repertoires, and stylization and stance, focusing on preadolescent/adolescent speech patterns and forms in the north of England. Observation is a part of this research, but most



important are the recordings of real-life interactions taking place between key informants and the different people they encounter during their school day. Like Labov, Eckert, and Rampton, Snell's task is the fine-grained analysis of particular linguistic features (e.g., the use of "me" as a possessive pronoun) as overall identity markers, as well as class markers, both locally and in British society at large. She then frames trends that she finds as *enregistered voices* (Agha, op. cit.) and establishes both how a class condition, as way of life, may be seen to generate particular identities in society and how identity is made, as emergent and as effect, via the use of particular speech patterns and other multimodal behavior.

This type of research falls within the realm of Marx's (op. cit.) *class in itself*, and what Rampton (2006) calls the "ordinary experience, and everyday discourses, activities and practices – the 'primary realities' of practical activity" (p. 222). But what of research on language and class in educational contexts which may be seen to be about Marx's *class for itself*, and what Rampton (2006) calls "secondary or 'meta-level' representations," that is, "ideologies, images, and discourses about social groups, about the relations of power between them, and about their different experiences of material conditions and practical activity" (pp. 222–223)? The answer to this question is that while there has been research focusing on Rampton's "secondary or 'meta-level' representations" in a range of language in education settings, such as complementary schools in Britain (Blackledge and Creese 2010), secondary school Japanese returnees (Kanno 2003), secondary school students in London (Harris 2006), and universities in Britain (Preece 2010), there has been little mention of class in this work, with Harris going into such issues more than most.

---

## Problems and Difficulties

The biggest problem with class in language education research is its relative erasure and the fact that even when it is cited as important, it is seldom, if ever, defined in any detail (Rampton (2006) is a notable exception). However, beyond clarity regarding what class *is*, there is a long list of issues arising around the use of class as key construct. Here I will briefly deal with just two, the first being the relationship between class and identity. Is class an identity dimension, much like race, gender, or nationality? Or is it different? As I note elsewhere (Block 2014), there has been a tendency in the humanities and social sciences in recent years for scholars to adopt what might be termed a "culturist" approach to identity. This approach has arisen above all in the economically advanced nation-states of the world (and particularly in the Anglophone world), and it is connected with the rise of what some call "identity politics" or what Fraser (Fraser and Honneth 2003) sees as struggles related to "recognition." Recognition is about respect for others and a focus on key identity markers such as nationality, gender, race, ethnicity, religion, and sexuality, as well as the relationship of the individual to society at large, both as individual and as member of a community (or communities). Recognition may be seen as either in conflict with or as articulated with what Fraser calls "redistribution," which is concerned with the material bases of the life experiences people living as "collective

subjects of injustice [in] classes or class-like collectives, which are defined economically by a distinctive relation to the market or the means of production” (Fraser and Honneth 2003, p. 14). Fraser sets up a philosophical dilemma when she laments how “[t]he discourse of social justice, once cantered on distribution, is now increasingly divided between claims for distribution, on the one hand, and claims for recognition, on the other” (Fraser and Honneth 2003, pp. 7–8), attributing this shift to developments such as the demise of communism (both as a material and discursive alternative to capitalism), the rise to dominance of neoliberal economic ideology, and the aforementioned rise of identity politics.

One basic point here is that even if it intersects with identity dimensions, which Fraser sees as part of claims of recognition, class is not a modality of being of the same type as race, ethnicity, gender, nationality, or sexuality because it is first and foremost in the realm of distribution and redistribution of material resources, and it is not about respect and recognition. The solution to societal ills like racism and sexism, it seems, is for people to stop being racist and sexist, to accept diversity and to respect others as equals. These remedies do not work when it comes to class and class-based inequality, as accepting another’s relative poverty and respecting the position in society that it affords do not do anything to overturn material-based inequality. As Sayer (2005) has noted, the poor do not wish to have their poverty and poor living conditions affirmed, legitimized, and validated by mainstream middle-class and upper-class members of the society. What they want is the abolishment of class differences or, more modestly, their own individual escape from the relative deprivation and underprivileged conditions in which they live. In this case, recognition and respect are not enough, and language education research that has focused on class has not delved into this issue. And this is why the relative erasure of class from educational research is a genuine concern.

Another issue arising is how to develop an affective/experiential/psychological perspective, whereby class is understood as a “structure of feeling,” that is, a collection of “characteristic elements of impulse, restraint, and tone; . . . of consciousness and relationships; . . . [of] thought as felt and feeling as thought” (Williams 1977, p. 132). In Sennett and Cobb (1972), we see in practice what Williams is writing about. These authors explore the “hidden injuries of class” and the feelings of inadequacy, disappointment, disillusionment, and lack of fulfillment manifested by white working-class Americans living in the last years of Keynesian economics in the late 1960s. These individuals worry about a range of issues, from their own job security to the future of their children, whom they hope will do better than they have in life. Some years later, Bourdieu (1999) accessed similar sentiments among members of working class in 1990s France, who were starting to feel the effects of the first major wave of neoliberal policies in effect from the mid-1980s onward. More recently, there is talk of new experiences and dispositions among workers who are reframed as “neoliberal citizens”: “neoliberalism normatively constructs and interpellates individuals as entrepreneurial actors in every sphere of life . . . figure[ing] them . . . as rational, calculating creatures whose moral autonomy is measured by their capacity for ‘self-care’ – the ability to provide for their own needs and service their own ambitions” (Brown 2005, p. 43). This view of new ways

of being resonates with Boltanski and Chiapello's (2005) notion of the "new spirit of capitalism," which entails, among other things, the priming of the private over the public, individualism over solidarity, and flexibility over stability, all of which links back to Foucault's (2008) prescient work from 1979 on new technologies of the self in the (then nascent) neoliberal regimes of policy, practice, and discourse. The challenge is how to develop a coherent affective/experiential/psychological perspective on class based on the thinking of the authors cited here, which can then be operationalized in research. To date, this challenge has not been taken up by language education researchers.

---

## Future Directions

The two issues mentioned in the previous section are obvious bases for future research on class in language education. Another is class-based research on the teaching and learning of foreign languages around the world. This would include both English as an international language in most parts of the world and the teaching and other languages such as French, Mandarin, Arabic, and Spanish, which for different reasons have made their way onto the national curricula in a good number of countries (e.g., Mandarin, due to the rise of China as an economic powerhouse; French, due to its historical extension around the world). As I note elsewhere (Block 2012, 2014), in research on foreign language teaching and learning, class has appeared only sporadically and indeed has hardly been present.

Other language and teaching contexts which have received the attention of researchers, but without much attention to class, include English language immersion schools around the world (de Mejia 2002); French and Spanish immersion schools in North America (Heller 2006; Palmer 2009, respectively), complementary schools in increasingly multicultural and multilingual countries across Europe and other parts of the world (Lytra and Martin 2010); study abroad and student exchange programs around the world (Kinginger 2013); and "internationalized" higher education around the world in which English-medium instruction has become a common language education modality (Jenkins 2014). In all of these contexts, there is unequal access to and competence in the languages taught and learned as they both index and are indexed by class. However, while research to date has been effective in bringing certain socio-political issues to the fore (e.g., the language rights of individuals, enduring racism in many societies), there has been relatively little specific focus on the class-based issues arising. More could (and should) be done.

---

## Cross-References

- ▶ [Discourse Analysis in Educational Research](#)
- ▶ [Ethnography and Language Education](#)
- ▶ [Linguistic Ethnography](#)
- ▶ [Researching Identity in Language and Education](#)

- ▶ [Researching the Language of Race and Racism in Education](#)
- ▶ [Second Language Acquisition and Identity](#)

---

## Related Articles in the Encyclopedia of Language and Education

James Collins and Ben Rampton: [Language, Class, and Education](#). In Volume: Language Policy and Political Issues in Education

---

## References

- Agha, A. (2005). Voice, footing, enregisterment. *Journal of Linguistic Anthropology*, 15(1), 38–59.
- Apple, M. (1982). *Education and power*. Boston: Routledge and Kegan Paul.
- Bernstein, B. (1971). *Class, codes and control: Theoretical studies towards a sociology of language* (Vol. 1). London: Routledge and Kegan Paul.
- Bernstein, B. (1975). *Class, codes and control: Towards a theory of educational transmissions* (Vol. 3). London: Routledge and Kegan Paul.
- Bernstein, B. (1990). *Class, codes and control: The structuring of pedagogic discourse* (Vol. 4). London: Routledge and Kegan Paul.
- Blackledge, A., & Creese, A. (2010). *Multilingualism: a critical perspective*. London: Continuum.
- Block, D. (2012). Class and second language acquisition research. *Language Teaching Research*, 16(2), 188–205.
- Block, D. (2014). *Social class in applied linguistics*. London: Routledge.
- Block, D. (2015). Identity and social class: Issues arising in applied linguistics research. *Annual Review of Applied Linguistics*, 35, 1–19.
- Boltanski, L., & Chiapello, E. (2005). *The new spirit of capitalism*. London: Verso.
- Bourdieu, P. (1999). *The weight of the world: Social suffering in contemporary society*. Cambridge: Polity Press.
- Bourdieu, P. (1984). *Distinction*. London: Routledge.
- Bourdieu, P. (1991). *Language and symbolic power*. Cambridge: Polity.
- Bowles, S., & Gintis, H. (1976). *Schooling in capitalist America: Educational reform and the contradictions of economic life*. New York: Basic Books.
- Brown, W. (2005). *Edgework: Critical essays on knowledge and politics*. Princeton: Princeton University Press.
- Cheshire, J., Kerswill, P., Fox, S., & Torgersen, T. (2011). Contact, the feature pool and the speech community: The emergence of multicultural London English. *Journal of Sociolinguistics*, 15, 151–196.
- Coupland, N. (2007). *Style*. Cambridge: Cambridge University Press.
- de Mejia, A.-M. (2002). *Power, prestige and bilingualism*. Bristol: Multilingual Matters.
- Eckert, P. (1989). *Jocks and burnouts: Social categories and identity in the high school*. New York: Colombia University Press.
- Eckert, P. (2003). The meaning of style. *Texas Linguistic Forum*, 47, 41–53.
- Foucault, M. (2008). *The birth of biopolitics: Lectures at the Collège de France 1978–79*. Basingstoke: Palgrave Macmillan.
- Fraser, N., & Honneth, A. (2003). *Redistribution or recognition? A political-philosophical exchange*. London: Verso.
- Gramsci, A. (1971). *Selections from prison notebooks*. London: Lawrence & Wishart.

- Harris, R. (2006). *New ethnicities and language use: The emergence of Brasian identities*. Basingstoke: Palgrave.
- Heath, S. B. (1983). *Ways with words*. Cambridge: Cambridge University Press.
- Heller, M. (2006). *Linguistic minorities and modernity: a sociolinguistic ethnography*, 2nd edition. London: Continuum.
- Jenkins, J. (2014). *English as a lingua franca in the international university: The politics of academic English language policy*. London: Routledge.
- Kanno, Y. (2003). *Negotiating bilingual and bicultural identities: Japanese returnees betwixt two worlds*. Mahwah: Lawrence Erlbaum Associates.
- Kiesling, S. (2009). Style as stance: Can stance be the primary explanation for patterns of sociolinguistic variation? In A. Jaffe (Ed.), *Sociolinguistic perspectives on stance* (pp. 171–194). Oxford: Oxford University Press.
- Kinginger, C. (Ed.). (2013). *Social and cultural aspects of language learning in study abroad*. Amsterdam: John Benjamins.
- Kiriya, T. (2013). *Education reform and social class in Japan: The emerging incentive divide*. London: Routledge.
- Labov, W. (1966). *The social stratification of English in New York City*. Washington, DC: Center for Applied Linguistics.
- Labov, W. (1972 [1969]). The logic of nonstandard English. In P. Giglioli (Ed.) *Language social context* (pp. 179–215). Harmondsworth: Penguin. (Originally published in *Georgetown Monographs on Language and Linguistics*, 22, 1–22, 26–31).
- LaDousa, C. (2014). *Hindi is our ground, English is our sky: Education, language, and social class in contemporary India*. New York: Berghahn Books.
- Lytra, V., & Martin, P. (Eds.). (2010). *Sites of multilingualism: Complementary schools in Britain Today*. Trentham: Trentham Books.
- Marx, K. (1988 [1844]). *Economic and philosophic manuscripts of 1844*. Amherst: Prometheus Books.
- Marx, K. (1990 [1867]). *Capital* (Vol. 1). Harmondsworth: Penguin.
- Palmer, D. (2009). Middle-class English speakers in a two-way immersion bilingual classroom: “Everybody should be listening to Jonathan right now. . .”. *TESOL Quarterly*, 43, 177–202.
- Preece, S. (2010). *Posh talk*. Basingstoke: Palgrave.
- Rampton, B. (2006). *Language in late modernity: Interaction in an urban school*. Cambridge: Cambridge University Press.
- Rampton, B. (2010). Social class and sociolinguistics. *Applied Linguistics Review*, 1, 1–22.
- Rampton, B. (2011). Style in a second language. *Working Papers in Urban Language & Literacies*, 65.
- Reay, D., Crozier, G., & James, D. (2011). *White middle-class identities and urban schooling*. Basingstoke: Palgrave Macmillan.
- Sayer, A. (2005). *The moral significance of class*. Cambridge: Cambridge University Press.
- Sennett, R., & Cobb, J. (1972). *The hidden injuries of class*. New York: Norton.
- Sheng, X. (2014). *Higher education choice in China: Social stratification, gender and educational inequality*. London: Routledge.
- Snell, J. (2013). Dialect, interaction and class positioning at school: From deficit to difference to repertoire. *Language and Education*, 27, 110–128.
- Thompson, E. P. (1980 [1963]). *The making of the English working class*. Harmondsworth: Penguin.
- Weber, M. (1968 [1922]). *Economy and society* (Vol. 1–2). Berkeley: University of California Press.
- Weis, L., Cipollone, K. & Jenkins, H. (2014). *Class warfare: class, race, and college admissions in top-tier secondary schools*. Chicago: University of Chicago Press.
- Williams, R. (1977). *Marxism and literature* (1st ed.). Oxford: Oxford University Press.
- Young, M. (1971). *Knowledge and control: New directions for the sociology of education*. London: Collier Macmillan.

---

# Researching Identity in Language and Education

Saeed Rezaei

---

## Abstract

This chapter reviews and synthesizes the most applicable, useful, and practical methods and tools in researching identity in language and education. To this aim, this chapter starts with an introduction to the field of identity in language and education followed by early developments and major contributions. As the main focus of this chapter, the major methods, approaches, and tools to researching identity in language and education are then presented. Narrative inquiry, ethnography, interviewing, questionnaire, and diary keeping as the main methods of data collection are introduced. In each method presented, a few sample studies with their results are also provided. The strengths and shortcomings of each of these methods in researching identity are included in each section. In the last section of this chapter, some works in progress and future directions for research are given.

---

## Keywords

Identity • Narrative • Interview • Ethnography • Questionnaire • Diary

## Contents

Introduction .....	172
Early Development and Major Contributions .....	172
Research Methods and Tools: Problems and Difficulties .....	174
Narrative Inquiry and Analysis .....	174
Ethnography .....	176
Interview .....	176
Questionnaire .....	178
Diaries and Journals .....	178

---

S. Rezaei (✉)

Languages and Linguistics Center, Sharif University of Technology, Tehran, Iran

e-mail: [srezaei@sharif.edu](mailto:srezaei@sharif.edu)

---

Working in Progress and Future Directions .....	179
Cross-References .....	181
Related Articles in the Encyclopedia of Language and Education .....	181
References .....	181

---

## Introduction

With the rise of globalization and its ensuing effect on human lifestyle, one of the major concerns for sociolinguists and sociologists has been the major role that identity has acted in people's lives. More importantly, human encounters in intercultural communication contexts where people from diverse social, cultural, and linguistic contexts meet have engendered the vexed issue of with whose norms and values should people comply in international milieu. The importance of issues such as language, culture, gender, race, and ethnicity in the global village or the diaspora has instigated researchers to take identity issues in language and education studies more seriously.

Considering this rising trend in language and education research, a quick perusal of recent publications in the last decade demonstrates that a number of sociolinguists have been enormously attracted to the studies on identity in language and education. The publications of several books (e.g., Block 2007; Edwards 2009), journals with their special issues (e.g., *Journal of Language, Identity & Education*), and state-of-the-art reviews (e.g., Norton and Toohey 2011) all attest to the vitality of this area of research. Nonetheless, with the exception of Mallinson et al. (2013), Dervin and Risager (2014), and Holmes and Hazen (2014), there has not been sufficient contributions on the methods and tools in researching identity in language and education. Therefore, the present chapter aims to review early and major contributions in identity research with their methodological tools.

---

## Early Development and Major Contributions

Early studies on identity in applied linguistics and language education are associated with the works of Norton (1995, 2000) and followed by her in collaboration with others (e.g., Kanno and Norton 2003; Norton and Toohey 2011) or complemented and expanded by other researchers individually (e.g., Block 2007). Nevertheless, prior to Norton, there were several studies that used identity as the backbone of their research. According to Block (2007), they include Childs' study (1943) on heritage language and identity, Lambert's (1967) studies on learners' instrumental and integrative motivation in Quebec, some studies by Guiora and his colleagues (1980) on language ego, a series of studies by Schumann (e.g., Schumann 1976) on his acculturation model, and Schmidt's own account of learning Portuguese in Brazil (Schmidt and Frota 1986) where he had a double identity as a professor at a university and also a Portuguese language learner in a class. Although these studies

did not focus on identity in the theoretical framework that current researchers are adopting, they were closely related to the sociological aspects of language learning and development (e.g., the role of L1 identity, language ego, social interaction, and motivation in L2 development).

Childs (1943) investigated the attitudes of the second-generation Italian-Americans in the USA toward their heritage and their new American identity by using a questionnaire. Similarly, Lambert (1967) used a questionnaire to determine the attitudes of a group of English native speakers toward French in Quebec. Both Childs and Lambert drew on questionnaires as their data collection tools and did not employ interviewing, narratives, or ethnography. Guiora et al. (1980), in turn, were more experimental in design and focused on pronunciation as the main predictor of identity. They hypothesized if the injection of valium would increase ego permeability and more native-like pronunciation. Their study was related to identity research in that the researchers postulated that the consumption of alcohol or Benzodiazepine would affect learners' identity and level of empathy. The studies by Schumann (1976) also focused on questionnaires, tests, interviewing, and fieldwork, in closer proximity to the research approaches currently deployed in identity research (e.g., Norton 2000). In brief, the literature on early identity research in language and education shows that, on the one hand, the early works were mostly based on questionnaire data; however, this trend gradually waned and more qualitative methods such as ethnography and narrative inquiry gathered momentum. On the other hand, from a theoretical point of view, early studies focused on the essentialist view of identity, whereas current studies are based on poststructuralist views.

With regard to research method and approach, the majority of major contributions on identity in language education have capitalized on qualitative research methods inasmuch as current identity studies are mainly informed by poststructuralist theories considering identity as multiple, non-unitary, and malleable in nature, a site of struggle, and finally changing over time (Norton 2000) and accordingly rejecting the prototypical, essentialist, and fixed view of identity. The dominant theorists whose works build up the infrastructure of identity research come from the ideas of noted theoreticians in sociology and philosophy including Bourdieu, Foucault, Bakhtin, Weedon, and Butler, among some others.

One seminal study on language and identity is that of Norton (2000) who used her participants' written narratives to analyze their identity (re)construction. Her participants were newly arrived immigrant women from Peru, Poland, Czechoslovakia, and Vietnam who strived to position themselves in the Canadian language learning atmosphere. Norton capitalized on their diaries and essays, two interviews, and two questionnaires to find out that their learning experience and identity reconstruction were deeply affected by their race, gender, and class. Another study focusing on immigrant adult learners is by Teutsch-Dwyer (2002) about Karol, a 38-year-old Polish immigrant in California. The data collection procedure included recording Karol's naturally occurring words bimonthly, observation, and interviewing both Karol and his coworkers and girlfriend. In sum, the results of these early studies



established identity research within more qualitative research design with poststructuralism as their theoretical framework. They also paved the way for more studies being conducted on identity in language and education research.

---

## Research Methods and Tools: Problems and Difficulties

After reviewing the early studies on identity in language and education, their common research tools and methods should be introduced. Researching identity in language and education has been executed based on an array of research methods and tools including both quantitative and qualitative instruments. Quantitative instruments include questionnaire, and qualitative tools include narratives, ethnography, interview, and diary. In the following paragraphs, each of these methods is presented, and their strengths and weaknesses are discussed.

### Narrative Inquiry and Analysis

Narrative inquiry as a portmanteau word in current social science research (Andrews et al. 2013) and as one of the most popular qualitative methods for researching identity is delving into people's past, present, and future life stories to obtain a rich source of data about people's personal account of self and identity, not easily attainable in simple interviewing. Rooted in anthropology and sociology, in both oral and written form, narrative has become a popular approach in identity research in language and education studies. The dialogic, engaging, self-revealing, and, more importantly, the multilayered nature of data collected through narratives furnish the researchers with the most appropriate approach to collecting data about people's identity in education, a concept very subtle and hidden in people's sociological and psychological personality.

The antecedents which paved the way for narratives to be widely accepted in social sciences include the humanistic approaches giving due attention to individuality, and the second one came from the Russian structuralism (e.g., Mikhail Bakhtin) and French poststructuralism (e.g., Jacques Derrida) along with its ensuing postmodern, psychoanalytic, and deconstructivist approaches to identity (Andrews et al. 2013). In spite of the existence of both written and spoken narratives, early studies on identity in language education (e.g., Norton 1995) focused on written narratives in the form of participants' diaries and journals. Audio-recorded narratives, on the other hand, have been used by Menard-Warwick (2004) to explore the mediation between two adult immigrant English as a second language (ESL) students' gender identity and their second language learning.

Having been borrowed both theoretically and methodologically from other fields in social sciences including anthropology and sociology, narrative inquiry and analysis in the field of language studies are gaining more popularity and have been employed by language educationalists (e.g., Benson et al. 2013) and sociolinguists and discourse analysts (e.g., De Fina and Georgakopoulou 2011). Driven

by poststructuralist views, narrative analysis falls within discourse analysis methods with a more explicit focus on autobiographies and self-reports. Moreover, the *Journal of Narrative Inquiry* has become a robust and independent platform for this research method; besides, some special issues in Teaching English as a second language (TESOL) and linguistics have added to its enduring popularity (e.g., the special issue of *Text & Talk* in 2003 and *TESOL Quarterly* in 2011). Several other edited volumes (e.g., De Fina and Georgakopoulou 2015), books and monographs (Archakis and Tsakona 2012), and research papers (e.g., Tsui 2007) have utilized narrative inquiry and analysis as their focus in data collection. A recent example is Archakis and Tsakona (2012) who discuss how humorous and conversational narratives can generate critical language awareness and meta-narrative competence in language learners. They further provide a model according to which students can get emancipated from the inculcated ideologies prevalent in the society.

One more point in narrative studies is the distinction made between big and small stories, where the former denote the stories elicited in interviews and the latter refer to the everyday conversations uttered by people but not necessarily elicited (Bamberg and Georgakopoulou 2008). Georgakopoulou (2007), on the other hand, makes a distinction between narrative inquiry and narrative analysis and contends that narrative inquirers are after the *what* of their narrative data (i.e., what the content of the narratives reveals about their identity), whereas the narrative analysts are after the *how* of it (i.e., scrutinizing the discourse to find hints to the narrator's identity).

On the strengths and weaknesses of narratives in identity research, different positions are taken. The advantages include having more natural, authentic, and revealing data and also the point that narratives are more easily remembered (Bell 2011). However, certain methodological and practical issues are raised about narratives including the epistemology upon which it is based, the way different researchers interpret the narratives and how time would affect this interpretation, the longitudinal and subsequently lengthy nature of such studies, the ethical issues concerning the participants and the confidentiality of the narratives collected, the symbiotic relationship between the narrator and the researcher which might affect the data collection and analysis, the bulk of data gathered and its difficulty in reporting it and getting it published in the limited spaces journals offer, and finally the reliability, validity, and generalizability issues (Bell 2011; Higgins and Sandhu 2015; Pavlenko 2007). In spite of all the abovementioned points, narratives in identity research can be triangulated with other research tools such as questionnaires and ethnography in order to make up for its potential weaknesses.

A good example of narratives in identity research is Tsui (2007) who traced the identity formation and reconstruction of an English as a Foreign Language (EFL) learner and teacher named Minfang during a 6-year longitudinal case study. The narrative analysis revealed that Minfang struggled with multiple identities (e.g., appropriating and reclaiming meanings of EFL learning) that were constituted by negotiation of meanings. Her findings further showed that Minfang's identity was

“relational as well as experiential, reificative as well as participative, and individual as well as social” (p. 678).

## Ethnography

As a qualitative research method used primarily by social scientists especially anthropologists, ethnography refers to the researcher’s prolonged engagement and participation in a particular research site registering the events from an emic perspective. In ethnography, researchers capitalize on several different data collection tools including video and audio recording, participatory observation, interviewing and narratives, questionnaires, archival notes, journal keeping, and field notes to achieve triangulation. Ethnographic research shies away from theoretical presuppositions and instead allows the fieldwork and data collected thereof to bespeak.

In spite of its credibility and acceptability as a research tool in identity research, ethnography is not devoid of its own drawbacks. One problem with ethnographic research is the time and funds needed to do longitudinal and prolonged engagement in the research site which in turn would yield detailed and rich data (Blommaert and Jie 2010). In addition, in some contexts, there are several ethical issues raised. Also, the presence of the researcher in the research site sometimes affects the normal everyday behavior of the community under study (i.e., Hawthorne effect), and hence, issues with regard to reliability can be raised. Moreover, the way an ethnographer is interpreting the behaviors is not absolutely right and could be a mere misinterpretation (i.e., halo effect) especially if the researcher is an outsider. In spite of all these criticisms, ethnography has shown to be a very useful data collection method in identity research. Most of the cutting edge research with ethnography as their focus is published in the journal of *Ethnography*.

On the practical side, several identity researches in language and education have used ethnography as either the sole or a complementary research tool for data collection. Examples include King and Ganuza (2005) who used ethnographic interviews and observation to analyze the national, cultural, and linguistic identification among Chilean-Swedish transmigrant adolescents in and around Stockholm. They focused on the attitudes of their participants toward ethnic and national identity, how they perceived Chileans and Swedes, and their code-switching practices. The results of their study indicated that Chilean migrants were constructing a mixed new identity in Sweden that encompassed both their Chilean and Swede selves.

## Interview

As a qualitative and sometimes quantitative research tool formed as the co-construction of meanings between the interviewer and interviewee, interviewing similar to narrative inquiry/analysis is a useful method of data collection in identity

research and includes structured, semistructured, or unstructured types conducted either individually or in focus groups. Researchers within identity studies often resort to face-to-face in-depth interviewing by gaining a rapport with the participants and having the least intrusion (unstructured). However, there are times when researchers utilize more structured interviewing (like a questionnaire) to reach their intended objectives.

Interviewing, similar to narratives, showcases its own strengths and weaknesses. One of the fundamental shortcomings of interviews in identity research is that they are not authentic and disallow the researcher to probe into the deep aspects of identity usually seen in action. On the one hand, similar to narratives, in interviewing, the interviewer cannot easily elicit information sensitive to the interviewees as they are at times reluctant to talk about personal issues. The analysis of interview data is also time-consuming and a cumbersome task making the researchers resort to grounded theory, content and thematic analysis (either by hand or via NVivo), or conversation/discourse analysis tools revealing similar downsides, such as generalizability. On the other hand, interviewing has several advantages in identity research. One example is when the interviewer does not know the community's language or the interviewees are illiterate to fill out a questionnaire. In such cases, a translator or assistant can be employed. Also interviewing allows intimacy to grow between the researcher and the participants and therefore deeper sources of data can be obtained.

Interviewing has been extensively used in identity research most often employed along with questionnaires in mixed methods research and sometimes used as a narrative tool referred to as narrative interviewing. Examples of interviewing in identity research abound and include an early study by Norton (2000) who interviewed a group of immigrants in Canada and realized that their identity reconstruction as L2 learners and immigrants was strongly affected by their race, social class, and gender. One more interesting research is the study of gendered narratives of immigrant language learners in California by Menard-Warwick (2004). In a case study on two adult immigrant ESL learners from El Salvador and Mexico, Menard-Warwick utilized her participants' audiotaped interviews to dig out the relationship between social positioning, gender, and language learning. The results of her study, based on thematic analysis and coding, revealed that L2 learning success is determined by the way learners respond to the gender ideologies and positioning dictated by their community of practice. Another interesting research in which the researchers utilized interviewing – along with a myriad of other data collection tools and methods – is the one done by Bouchereau Bauer et al. (2015) who investigated two fourth-grade immigrant students' language and identity development in Germany. The results of their research based on the thematic analysis yielded interesting findings including the multilingual lived experience of the students in and out of school that could inhibit the normal instructional procedure for the immigrant kids. The results also showed that students were resistant to teaching German as a second language as it was boring and not engaging. Furthermore, the results of their research showed the low level of investment and motivation on the part of students.

## Questionnaire

Questionnaires and other survey instruments and checklists were primarily used in early attitudinal research, though some recent studies (e.g., Rezaei et al. 2014) have also capitalized on questionnaire data. Questionnaires are very valuable tools for large data collection studies in a short time to meet generalizability in results. However, some poststructuralist identity researchers are against the use of questionnaires since they cannot tap the nuances of people's identity. In other words, due to the closed-ended nature of questionnaires and respondents' lack of absolute commitment, the results of questionnaire studies are not per se sufficient and should be complemented by other research methods such as interviewing and ethnography. Therefore, questionnaires are most of the time used in conjunction with other research tools in identity research.

An example is Park (2012), who administered a questionnaire to 118 English language learners in order to find insight into the learners' identity in the Korean English as a Lingua Franca context. The results of her study indicated that social practices including the sociocultural norms in Korea determine, such as power relationships in the society, are determining identity options in Korean English language learners. Moreover, Gao et al. (2007) studied the relationship between motivation types and self-identity change among 2278 participants from 29 regions in China. They used a validated questionnaire for both motivation and self-identity to collect their data. One interesting result obtained in their study was that intrinsic interest in the target language and culture had a significant relationship with the productive and additive changes in self-identity.

It should be mentioned, however, that although questionnaires are disfavored by some poststructuralist researchers, they can yield rich data and can be used to obtain demographic information. Nevertheless, one problem with questionnaires in identity research is that they merely elicit attitudes, whereas people might behave differently from what they think or say in questionnaires. Besides, the development and validation of reliable survey instruments is a demanding job. Since the existing questionnaires for identity research are rarely applicable across different contexts, researchers are obliged to either develop their own survey instruments or modify, adapt, and finally pilot the instrument before the final administration for data collection.

## Diaries and Journals

Learner diaries or journals, also referred to as their autobiographical notes, are valuable introspective data collection tools in identity research which refer to recording one's experiences, feelings, anecdotes, and thoughts within certain time frames most often from a first person point of view (Bailey 1990). Contrary to ethnographic studies where the researcher is the sole recorder of events, diary studies provide some valuable data from the participants' own point of view in the least obtrusive method possible, something less achievable in ethnography, interview, and

questionnaire studies. Diaries, of course, are not only kept by participants but also ethnographers keep diaries through field notes.

Diaries and narratives are very similar, but the former are usually in written form, whereas the latter are often recorded in spoken form. In diary-based identity research (either written on paper or online), there should be a high motivation from the participants to keep a diary as it requires a lot of patience, energy, and skill. The participants' diarized reflections and language learning experiences can yield valuable information. With regard to the potential problems in diary studies, the most important one is recruiting willing and committed participants which is not easy and that is why in the majority of diary studies, the researchers themselves are the participants and diary keepers of their own studies (e.g., Schmidt and Frota 1986) and that is why researchers prefer interviewing as a better substitute since it is time-consuming for participants to keep a diary. In addition, diaries contain very private life events that cannot be readily delivered to a researcher. On the other hand, sometimes life histories may not be necessarily relevant to the objectives of the study; therefore, in order to keep the participants more focused on the purpose of the research, they should be given some directions on what to write in their diaries; otherwise, irrelevant diary entries may be inscribed. This should not of course be very prescriptive and dictating but let identity factors emerge. Another difficulty is to look through diary entries for recurring themes. And of course diary studies are not practical when the participants are not literate to read and write. In such cases, audio or video diaries can be employed (Gibson 1995). Finally, diary studies are usually case studies with less than ten participants and sometime only one participant exists. This may raise questions against the reliability, validity, and generalizability of study findings. To extol the benefits of diary studies, on the other hand, one can refer to the valuable data collected in diary studies. Since identity from a poststructuralist view is evolving and changeable, diaries can better capture and record individual's moment-by-moment or day-by-day identity change. One other benefit of diary studies is that the data collected can be kept for later investigation or cross-checking.

An early researcher who used diary as a data collection tool was Norton (2000) who asked her participants to keep a diary of their language learning lives in Canada. The results of the diary entries along with interviewing and questionnaire data showed that her participants' language learning and identity formation in the new context of Canada were closely related to their gender, class, and race in the society. In other words, social factors were the main predictors of immigrant language learning success in diaspora.

---

## **Working in Progress and Future Directions**

According to Norton (1995), early studies on language and identity suffered from a comprehensive social theory integrating the language learner and language learning aspects. For Norton language learning success was determined by social factors as much as (if not more than) psychological factors. For her, social investment was a crucial determinant in identity construction. Prior to Norton, studies on social

factors, including identity, in language learning were limited to quantitative and attitudinal studies linked to such psychological factors such as motivation (e.g., Lambert 1967). In respect to language and identity research, Block (2013) refers to three main existing issues: (1) the predominance of the social aspect of identity and neglecting its psychological aspect, (2) more attention should be given to the interrelationship between individual agency and social structures in language and identity research, and (3) the benefits associated with the inclusion of a socioeconomic and social class view in language and identity research should be also stressed. For these dimensions to sustain and nurture, based on the abovementioned tools, methods, and research approaches, future studies welcome more mixed methods research to compensate for the shortcomings of qualitative and quantitative approaches.

One other issue that can be followed by future researchers is related to the lack of clear conceptualization of language and identity. In spite of the vast literature on the topic, many studies have failed to provide a clear definition for identity as far as the concept of identity itself is slippery and hard to define especially when investigated from a poststructuralist viewpoint. In other words, the definitions provided in the literature cannot encompass the subtlety and nicety of the term identity and accordingly masks its complex nature. As far as various definitions, all malleable in nature, are provided by sociolinguistics for the concept of identity in language studies, the construct validity of identity is also jeopardized. From a more scientific point of view, a more operational definition for identity in language and education should be provided so that researchers can avoid the prevailing less tangible view of identity. Although a counterargument might be raised here against quantifying identity, similar treatments have been given to other once-non-quantifiable constructs such as anxiety and stress that are currently operationalized through questionnaires. In addition, the subcomponents of identity should be also introduced to better tap the whole construct.

Another problem inherent in identity research in language and education is that less than ten people usually make up the whole participants of such studies, hence exposing certain threats to the reliability and generalizability of the findings inasmuch as these researchers seem to be rarely after generalization but description of a small cohort of participants. The overreliance on simple content or theme analytic approaches to data analysis usually boils down the findings to some recurring themes seen in their data. Mixed methods studies can be employed to capture and hence better present the complex, malleable, and fluid nature of identity. The reconciliation of qualitative and quantitative research methods, tools, and designs could serve the pitfalls each of these two theoretical approaches is exposed to. Poststructuralists, however, prefer to utilize multiple qualitative tools with questionnaire as the primary supplementary tool.

Future researchers should also more rigorously tackle the abovementioned areas. In addition, as technology has become prevalent in education, more attention should be allocated to language and identity issues in social media and networks. Identity issues in the online world will probably be more seriously researched in the near future. Besides, more research should focus on the emergence of new media and its

effect on the formation of identity. The impact cinema, theater, literature, and other forms of art can have on the formation of identity in language, and education studies should be also more seriously researched.

---

## Cross-References

- ▶ [Ethnography and Language Education](#)
- ▶ [Narrative Inquiry and Multicultural Education](#)
- ▶ [Research Approaches to Narrative, Literacy, and Education](#)
- ▶ [Second Language Acquisition and Identity](#)
- ▶ [Second Language Acquisition Research Methods](#)

---

## Related Articles in the Encyclopedia of Language and Education

Jasmine Luk Ching Man: [Classroom Discourse and the Construction of Learner and Teacher Identities](#). In Volume: Discourse and Education

---

## References

- Andrews, M., Squire, C., & Tamboukou, M. (Eds.). (2013). *Doing narrative research*. London: Sage.
- Archakis, A., & Tsakona, V. (2012). *The narrative construction of identities in critical education*. New York: Palgrave Macmillan.
- Bailey, K. M. (1990). The use of diary studies in teacher education programs. In J. C. Richards & D. Nunan (Eds.), *Second language teacher education*. New York: Cambridge University.
- Bamberg, M., & Georgakopoulou, A. (2008). Small stories as a new perspective in narrative and identity analysis. *Text & Talk*, 28(3), 377–396.
- Bell, J. S. (2011). Reporting and publishing narrative inquiry in TESOL: Challenges and rewards. *TESOL Quarterly*, 45(3), 575–584.
- Benson, P., Barkhuizen, G., Bodycott, P., & Brown, J. (2013). *Second language identity in narratives of study abroad*. New York: Palgrave Macmillan.
- Block, D. (2007). *Second language identities*. London: Continuum.
- Block, D. (2013). Issues in language and identity research in applied linguistics. *Elia: Estudios de lingüística inglesa aplicada*, 13, 11–46.
- Blommaert, J., & Jie, D. (2010). *Ethnographic fieldwork*. London: Multilingual Matters.
- Bouchereau Bauer, E., Guerrero, B., Homberg, S., & Bos, W. (2015). Understanding students with immigration backgrounds: A German case of students' language and identity in development. *Journal of Language, Identity & Education*, 14(5), 302–318.
- Childs, I. L. (1943). *Italian or American? The second generation in conflict*. New Haven: Yale University Press.
- De Fina, A., & Georgakopoulou, A. (2011). *Analyzing narrative: Discourse and sociolinguistic perspectives*. Cambridge: Cambridge University Press.
- De Fina, A., & Georgakopoulou, A. (2015). *Handbook of narrative analysis*. Malden: Wiley-Blackwell.
- Dervin, F., & Risager, K. (Eds.). (2014). *Researching identity and interculturality*. New York: Routledge.



- Edwards, J. (2009). *Language and identity: An introduction*. Cambridge: Cambridge University Press.
- Gao, Y., Zhao, Y., Cheng, Y., & Zhou, Y. (2007). Relationship between English learning motivation types and self-identity changes among Chinese students. *TESOL Quarterly*, 41(1), 133–155.
- Georgakopoulou, A. (2007). Thinking big with small stories in narrative and identity analysis. In M. Bamberg (Ed.), *Narrative— State of the art* (pp. 145–154). Amsterdam: Benjamins.
- Gibson, V. (1995). An analysis of the use of diaries as a data collection method. *Nurse Researcher*, 3(1), 61–68.
- Guiora, A., Acton, W., Erard, R., & Strickland, F. (1980). The effects of benzodiazepine (valium) on permeability of language ego boundaries. *Language Learning*, 30, 351–363.
- Higgins, C., & Sandhu, P. (2015). Researching identity through narrative approaches. In M. Bigelow & J. Ennsner-Kananen (Eds.), *The Routledge handbook of educational linguistics* (pp. 50–61). New York: Routledge.
- Holmes, J., & Hazen, K. (Eds.). (2014). *Research methods in sociolinguistics*. Malden: Wiley-Blackwell.
- Kanno, Y., & Norton, B. (Eds.). (2003). Imagined communities and educational possibilities [Special issue]. *Journal of Language, Identity and Education*, 2(4), 241–249.
- King, K., & Ganuza, N. (2005). Language, identity, education, and transmigration: Chilean adolescents in Sweden. *Journal of Language, Identity, and Education*, 4(3), 179–199.
- Lambert, W. E. (1967). A social psychology of bilingualism. *Journal of Social Issues*, 23(2), 91–109.
- Mallinson, C., Childs, B., & Van Herk, G. (2013). *Data collection in sociolinguistics: Methods and applications*. London: Routledge.
- Menard-Warwick, J. (2004). I always had the desire to progress a little: Gendered narratives of immigrant language learners. *Journal of Language, Identity, and Education*, 3(4), 295–311.
- Norton, B. (1995). Social identity, investment, and language learning. *TESOL Quarterly*, 29, 9–31.
- Norton, B. (2000). *Identity and language learning*. London: Longman.
- Norton, B., & Toohey, K. (2011). Identity, language learning, and social change. *Language Teaching*, 44(4), 412–446.
- Park, H. (2012). Insight into learners' identity in the Korean English as a lingua franca context. *Journal of Language, Identity & Education*, 11(4), 229–246.
- Pavlenko, A. (2007). Autobiographic narratives as data in applied linguistics. *Applied Linguistics*, 28(2), 163–188.
- Rezaei, S., Khatib, M., & Baleghizadeh, S. (2014). Language identity among Iranian English language learners: A nationwide survey. *Journal of Multilingual and Multicultural Development*, 35(5), 527–536.
- Schmidt, R., & Frota, S. (1986). Developing basic conversational ability in a second language: A case study of an adult learner of Portuguese. In R. R. Day (Ed.), *Talking to learn: Conversation in second language acquisition* (pp. 237–326). Rowley: Newbury House.
- Schumann, J. (1976). Social distance as a factor in second language acquisition. *Language Learning*, 26(2), 135–143.
- Teutsch-Dwyer, M. (2002). (Re)constructing masculinity in a new linguistic reality. In A. Pavlenko, A. Blackledge, I. Piller, & M. Teutsch-Dwyer (Eds.), *Multilingualism, second language acquisition, and gender* (pp. 175–198). Berlin: Mouton de Gruyter.
- Tsui, A. (2007). Complexities of identity formation: A narrative inquiry of an EFL teacher. *TESOL Quarterly*, 41(4), 657–680.

---

# Second Language Acquisition Research Methods

Rebekha Abbuhl and Alison Mackey

---

## Abstract

Since its inception in the 1960s, the field of second language acquisition (SLA) has sought to document and explore how children and adults acquire a nonnative language. Researchers have investigated the linguistic, cognitive, social, contextual, psychological, and neurobiological characteristics of second language (L2) learning, processing, and use. Typical research questions include: What are the characteristics of learner interlanguage? How do individual differences, such as working memory capacity, impact the learning of an L2? How does the social context (such as stay-at-home vs. study abroad) influence the fluency, accuracy, and complexity of learner language? How do different types of motivation impact the learning process? How is the L2 processed in the learner's mind and how is this affected by age of acquisition? To investigate these and many other questions, SLA researchers have at their disposal a large array of research designs. In this chapter, we will discuss various research designs, including quantitative, qualitative, and mixed methods traditions. We will also address current works in progress and examine recent topics of concern related to the conducting of research on L2 learning. Finally, we will conclude with future directions for SLA research.

---

## Keywords

Second language research • Quantitative research • Qualitative research • Research design • Study quality • Replications • Mixed methods studies • Statistics • Second language acquisition

---

R. Abbuhl (✉)

Department of Linguistics, California State University, Long Beach, CA, USA  
e-mail: [rebekha.abbuhl@csulb.edu](mailto:rebekha.abbuhl@csulb.edu)

A. Mackey (✉)

Department of Linguistics, Georgetown University, Washington, DC, USA  
e-mail: [mackeya@georgetown.edu](mailto:mackeya@georgetown.edu)

## Contents

Introduction .....	184
Early Development .....	184
Major Contributions .....	185
Quantitative Research .....	185
Qualitative Research .....	187
Works in Progress .....	189
Problems and Difficulties .....	189
Future Directions .....	191
Cross-References .....	192
References .....	192

---

## Introduction

Second language researchers seek to understand a wide variety of issues related to children's and adults' acquisition of a nonnative language. In this chapter, we begin by discussing early research in the field. We overview developments in quantitative, qualitative and mixed methods research methodology. Works in progress, including a repository for data collection instruments in second language acquisition research, are discussed. The field's growing concern with research quality issues (such as reliability, replicability, and the use and reporting of statistics) are also addressed, along with proposals to strengthen the training of future researchers and expand the scope of the field through big data.

---

## Early Development

Second language acquisition as a field has grown exponentially over the past half century, encompassing a wide variety of research foci and methods, all of which have their roots in early lines of inquiry. In the 1960s, learning a second language was seen primarily as a matter of habit formation. The main task facing second language learners was to learn new L2 habits and not let first language (L1) habits interfere in the process (at the time, the main source of error in the L2 was thought to be the L1). A large body of literature emerged that sought to compare languages in order to identify points of difference and predict areas of difficulty. In the 1970s, influenced by research that argued that innate linguistic knowledge was the driving force behind first language acquisition, researchers began to shift their focus away from L1/L2 differences and toward universals in L2 learning. One common study type at the time is exemplified by the "morpheme order study" (e.g., Dulay and Burt 1974), which involved researchers collecting samples of speech and writing from L2 learners and examining the learners' accuracy rates. The goal of such studies was to determine whether there was a fixed order in which particular morphemes were acquired, irrespective of the L1 of the learner. Also common in the 1970s and 1980s were studies that sought to ascertain whether innate linguistic knowledge (in the

form of Universal Grammar, or UG) was still available to L2 learners. Such studies typically compared the judgments of native and nonnative speakers on grammaticality judgment tests, among other methods. The 1970s and 1980s also saw a growing interest in affective factors and how they impact L2 learning. The constructs of instrumental and integrative motivation, for example, received considerable research attention, and many studies employed questionnaires to investigate these and other affective factors. By the 1990s, this focus had expanded to include learner-internal cognitive factors, such as attention and awareness, working memory, and input processing strategies. In addition to learner-internal factors, researchers in the 1980s and 1990s also began to devote more attention to the conditions of language learning, in terms of the input learners were exposed to, the output they produced, the instruction and feedback they received, and the types of interactions in which they engaged. Studies on the effects of age of acquisition also became increasingly common at this time, as researchers attempted to better understand the relationship between age of learning and ultimate attainment in the L2.

As this brief review indicates, the field considerably expanded its research scope from the 1960s to the 1990s. With this expansion came a greater concern for research methods, both quantitative and qualitative. In the early years of SLA research, “despite the importance of methodology for research outcomes and ultimately for theory construction, there was little debate . . . that went beyond critiquing particular studies” (Grotjahn and Kasper 1991, p. 110). This began to change with the publication of one of the first books on SLA research, Hatch and Farhady (1982)’s manual on research design and statistics. Since that time, a multitude of books and articles have been published on quantitative and qualitative research, all of which have helped SLA researchers better understand the options available to them as they investigate the complex, interdisciplinary topic of acquiring a nonnative language (e.g., Dörnyei 2007; Duff 2008; Larson-Hall 2010; Mackey and Gass 2012; Porte 2010; Richards 2003, among many others; see Brown 2011; Loewen and Gass 2009 for more comprehensive lists).

As we will see in the following sections, the field is continually seeking to make progress in the quality of its research, and debate continues about particular topics (for example, the roles of replications and mixed methods research). We will provide a brief overview of quantitative and qualitative research in SLA next, before discussing these debates in the sections “[Problems and Difficulties](#)” and “[Future Directions](#).”

---

## Major Contributions

### Quantitative Research

Quantitative research, traditionally defined, refers to research that stresses the importance of large groups of randomly selected participants, manipulating variables within the participants’ immediate environment and determining whether there is a

relationship between the manipulated (independent) variable and some characteristics or behaviors of the participants that is measured (the dependent variable). Statistical procedures are used to determine whether the relationship is statistically significant – and when it is significant, the results are typically generalized to a larger population beyond the immediate group of participants.

Many different quantitative research designs are available to SLA researchers (see Abbuhl et al. 2013 for a detailed review). In within-subjects designs, a single group of participants is measured at multiple times or under multiple conditions. The simplest of these repeated-measures designs, as they are also known, involves measuring one group of participants twice on a single variable. For example, a researcher could measure her or his students' grammatical accuracy at the beginning and end of the semester. This basic design can be made more complex by adding additional measurement times or conditions. For example, a researcher could add a third measurement time, such as a delayed posttest, to assess the long-term retention of learning (see Long 2006 for a discussion on the importance of delayed posttests). The researcher could also make the design more complex by adding additional dependent variables, thus creating a multivariate design. Returning to our example above, the researcher could measure the students' grammatical complexity and fluency in addition to their grammatical accuracy, once at the beginning of the semester and again at the end.

Another type of research design that typically consists of a single group of individuals is the correlational study. Here, the researcher measures two or more different variables for each participant in order to determine if there is a relationship between those variables. Researchers have used this approach to investigate, among other things, the relationship between age of arrival and accent, anxiety and written production, and amount of L1 use/L1 input on performance in the L2.

Between-groups designs are also common in the field of SLA. In the simplest between-group design, there is one dependent variable and one independent variable. The independent variable has two or more levels with different participants in each level. Often one of these levels is a control – a group that does not receive any treatment. Control groups are considered an important characteristic of experimental studies, as they allow researchers to better isolate the effect of the treatment. For example, Granena and Long (2013) used age of onset to divide learners into three age groups and then compared those groups with respect to their performance on L2 phonology, lexis/collocation, and morphosyntax. Researchers can also add independent variables, resulting in a multifactor (also called factorial) design. This type of design allows researchers to examine the effect of each independent variable separately (these are known as main effects) and to look at the combined effect of those independent variables (interaction effects).

Mixed designs, which employ aspects of both between-subjects and within-subjects variables, are extremely common in the SLA literature. For example, researchers frequently compare a control to a treatment group, often at multiple points in time (e.g., at the beginning and end of the semester), and, in addition, seek to establish whether there are changes within each group over time. Sheen (2010)

used this approach to investigate the effect of feedback type and testing time (pretest, posttest, delayed posttest) on ESL learners' production of English articles.

While quantitative research can shed light on many aspects of learning and development, qualitative research can offer a different perspective, one that is often grounded in teachers' and learners' experiences and involves taking a more holistic and contextualized perspective in relation to the many factors that interact in second language learning. Used in tandem with quantitative research in a mixed methods approach (which we address in the *Future directions* section), or on its own, qualitative research can yield a clearer understanding of SLA. We turn next to examining qualitative research in more depth.

## Qualitative Research

While considerations of research design are typically discussed with respect to quantitative research (where there is an emphasis on carefully designing all aspects of the research process prior to data collection), recent years have seen increasing attention to research design in qualitative studies as well. Qualitative research generally refers to research that places primary importance on studying small samples of purposely chosen individuals. Qualitative research does not attempt to control contextual factors but rather seeks, through a variety of methods, to understand issues from the informants' points of view and to create a rich, holistic, and in-depth picture of the phenomena under investigation. There is less of an emphasis on statistics (and concomitant attempts to generalize the results to wider populations) and more of an interest in the individual and their immediate and relevant contexts. An additional characteristic that is often mentioned when describing qualitative research is that it is inductive – that is, that it does not begin with hypotheses to be tested or models to be supported but rather seeks to develop insights from the patterns seen in the data. Another common idea in relation to qualitative work is the perspective on the learner, or small groups of learners, as cases. By taking a case study approach, qualitative researchers seek to understand and report research from the perspective of the individual.

Although this description stands in contrast with that presented for quantitative research (with its emphasis on randomization, statistics, and generalizability), it should be understood that quantitative and qualitative approaches are not polar opposites (as the traditional labels of *positivistic* and *interpretivist* for quantitative and qualitative research, respectively, sometimes imply).

With respect to qualitative research design, it has been stated that “no aspect of the research design is tightly preconfigured and a study is kept open and fluent so that it can respond in a flexible way to new details and openings that may emerge during the process of investigation” (Dörnyei 2007, p. 37). Nevertheless, as Richards and Morse (2007) note, “freedom from a preemptive research design should never be seen as a release from a requirement to have a research design” (p. 73). Two questions in particular worth addressing prior to data collection concern the number

of individuals, groups, or entities (i.e., cases) to study and the time frame of the investigation.

With respect to the number of cases to investigate, qualitative researchers may choose to employ single case or multiple case studies. In single case studies, a single person, group, institution, or entity is chosen as the focus of an in-depth and contextually sensitive investigation (Duff 2008). This may be an intrinsic case study, in which a case is chosen for its uniqueness (for example, Biedroń and Szczepaniak 2009 used an intrinsic case study to examine a talented foreign language learner). Alternatively, it may be an instrumental case study, in which a case is chosen for its typicality and how it can illuminate the concerns of a larger population (for example, Lardiere 2006 examined evidence of fossilization in a nonnative speaker of English). In a multiple case study, the researcher may look at several cases simultaneously in order to examine the similarities and differences of the cases. Abu-Rabia and Kehat (2004), for example, examined ten late but successful foreign language learners in order to determine what those individuals had in common.

Using multiple cases can also help the researcher incorporate the element of comparison into qualitative research designs. Although comparison designs are more commonly associated with experimental research, multiple cases can be used in qualitative research to examine how different phenomena manifest themselves in different groups or settings. The researcher may select one group to serve as a type of control. For example, if the researcher is investigating the challenges that second language writers face when writing academic papers, she or he might include a control sample of native speakers in order to better understand and isolate the effect of language background.

Consideration should also be made to the time frame of the study. Both case studies and ethnographies (a type of qualitative research that “aims to understand and interpret the behaviors, values, and structures of collectivities or social groups with particular reference to the *cultural* basis for those behaviors and values,” Duff 2008, p. 34, italics in original) commonly employ longitudinal designs. Many researchers have argued that prolonged engagement is necessary not only to build rapport with the participants but also to collect the kind of rich data needed to present a holistic and detailed picture of the phenomena under investigation. A longitudinal approach can also facilitate triangulation, or the process of gathering data using multiple, independent methods.

Of course, it needs to be kept in mind that considerations on qualitative research design cannot be boiled down to simple decisions about the number of participants and the time frame of the study. There are a multitude of qualitative approaches, including the ones we have discussed here: case studies, ethnography, and so on, as well as phenomenology, ethnomethodology, and grounded theory. The exact approach(es) and cyclical analyses chosen will have ramifications concerning the data collection procedures that are used as well as the interpretations of that data (see Richards 2003; Duff 2008 for detailed discussions). Nevertheless, considering participant and timing issues can help guide the iterative process that is qualitative research design.

---

## Works in Progress

A number of works are in progress related to the conducting of research in SLA. For example, a recent development is IRIS (Instruments for Research into Second language learning, <https://www.iris-database.org>), a project funded by the Economic and Social Research Council and the British Academy. IRIS is a digital repository of data collection instruments used in second language acquisition research. This freely accessible online database contains an extensive range of instruments, embracing different types of media and modes of data elicitation. It is fully searchable using a number of parameters, such as target language, resource type, and linguistic feature (s). IRIS is designed to facilitate research into areas such as the effectiveness of different types of instruction, the geographical or sociocultural contexts in which second languages are used and learned, the stakeholder opinions about language use and its impact on learning, and the linguistic or cultural identity. It aims to bring far-reaching and permanent benefits to the field of second language research, ensuring greater visibility and accessibility of the primary data collection tools, improving the quality of meta-analyses, and enhancing the replicability of research agendas (Marsden and Mackey 2014). We are also seeing increasing concern for quality in the field of applied linguistics in general. Plonsky (2013), for example, has provided an overview of quality issues in second language studies. Although he noted systematic strengths, Plonsky also pointed to a number of problems, including a lack of control in experimental designs, incomplete and inconsistent reporting practices (which has often been discussed), and low statistical power, which is an increasing concern as the field becomes more statistically rigorous. The American Association for Applied Linguistics (AAAL) tasked a subcommittee in 2014 with the responsibility of assessing and making recommendations for improving research quality in the field. This committee, chaired by John Norris, is comprised of AAAL members who have carried out research from quantitative, qualitative, and mixed methods approaches (Patsy Duff, Alison Mackey, and Luke Plonsky).

---

## Problems and Difficulties

As stated in the introduction, there was little published discussion on research design and study quality in the early years of SLA research. However, as the field of SLA has matured, considerably more attention has been devoted to these matters. With regard to quantitative research, three markers of study quality have received particular attention: validity, reliability, and, more recently, replicability.

Validity refers to the extent to which one can make correct generalizations based on the result of a particular measure used. Researchers typically distinguish between two major types of validity: internal validity (the degree to which confounding variables are eliminated) and external validity (the degree to which findings can be generalized to a wider population of learners). Researchers should be aware of various factors that can compromise validity – including participant attrition and maturation, instrument and test effects, and the nonrepresentativeness of the



particular sample of learners at hand – and take adequate steps to minimize the impact of these factors (Porte 2010).

Reliability is the degree to which results are dependable and relates to the consistency of scores by different raters (interrater reliability), as well as the consistency of measurements by different instruments (instrument reliability). In recent years, there has been increasing demand for SLA researchers to focus more on reliability and, in particular, to report interrater reliability statistics (e.g., Polio 1997). If researchers do not provide sufficiently detailed information about how judgments are made (e.g., how an L2 learner's proficiency is assessed) and on the extent of agreement or disagreement between raters with respect to those judgments, this can compromise the replicability of the study.

Replicability refers to the ability to repeat a study in the same or different contexts and to obtain analogous results. If the results of a study cannot be replicated, this may suggest that the original results were spurious, which could curtail the generalizability of the original study. Researchers have called attention to the scarcity of replications in the field and have argued that replications can help “interpret empirical research because they provide a ‘second opinion’ on the hypotheses, methods, and/or results presented in the original work” (Language Teaching Research Panel 2008, p. 1; see also Porte 2012). With the increased emphasis on data sharing and result checking (e.g., Plonsky et al. 2015), replications have a crucial role to play in promoting transparency and a more collaborative approach to SLA research.

As noted above, recent years have also witnessed increased attention to the appropriate use and reporting of statistics (Loewen and Gass 2009). There have been repeated requests, for example, that researchers report sufficient information so as to allow readers to assess the practical significance of the results (and to facilitate meta-analyses). Typically, this is done through the reporting of effect sizes (which, unfortunately, is not yet common practice in the field). Effect size can also be calculated by interested readers if the researcher reports means, standard deviations, and sample size, but scholars have noted that this information is not always available either (e.g., Plonsky 2013). There have also been suggestions in the literature that researchers report confidence intervals and power, both of which can increase the statistical rigor of SLA studies (e.g., Larson-Hall 2010). To the field's credit, fewer studies are relying solely on descriptive statistics and more are using advanced statistical procedures (Gass 2009). However, relatively recent statistical advances, such as the use of robust statistics and bootstrapping, remain uncommon (Larson-Hall and Herrington 2010), and scholars have provided evidence that this may have the effect of inflating the Type I error rate (Plonsky et al. 2015). The use of mixed-effects statistical models, advocated as an alternative to ANOVAs, also continues to be scarce (Cunnings 2012).

Discussions regarding study quality can also be heard regarding qualitative research, including the need for the research to have credibility, transferability, and dependability. Credibility means that the findings are believable to the research population being studied. Suggestions for enhancing credibility include continuing the data collection procedure with enough intensity over a sufficient length of time to accustom the participants to the research (and thus ensure that they are behaving

naturally) and collecting the data in as many contexts and situations as possible (e.g., Mackey and Gass 2012). Transferability refers to whether the findings from the study can be applied (or transferred) to other contexts. Although transfer is not the goal of all research, this helps make it possible to draw comparisons across studies. In order to do this, providing a “thick” description – that is, a description which reports in sufficient detail the particulars of the study and its participants – is necessary. Similarly, when the research context and relationships among the participants have been reliably characterized, the research may be said to be dependable. One way for this to be accomplished is by asking the participants themselves to review the patterns in the data – ideally, data that are electronically recorded so as to help recreate the original context in which the data were gathered.

---

## Future Directions

Researchers have sought to continually expand the research horizons of SLA by addressing issues of study quality and statistical rigor. Another direction for future research is to make greater use of what is known as split, mixed, or combination methods research. For example, in a convergent parallel design, the researcher conducts quantitative and qualitative data collection strands concurrently, with both strands receiving equal emphasis. Other mixed methods designs involve strands with unequal emphasis. For example, in the explanatory sequential design, a researcher may start the study with a quantitative strand and then follow it with a secondary qualitative phase. This final phase helps shed more light on the quantitative results. (The reverse is also possible; see Abbuhl et al. 2013 for a more detailed discussion.)

Although increasingly common in both the field of SLA and elsewhere, it should be noted that mixed methods have not been without controversy. Some researchers claim that the two approaches are epistemologically and ontologically incompatible, making split methods little more than unprincipled methodological opportunism. However, while the debate is ongoing, there is increasing consensus in various fields that qualitative and quantitative research methods are in fact compatible and that the judicious and principled use of both methods can allow the researcher to examine different aspects of the same problem (e.g., Hashemi and Babaii 2013).

Another new direction for second language research involves L2 corpora. The use of learner corpora and the possibility of so-called Big Data, together with the proliferation of available online data from social media, are beginning to allow second language researchers to consider their hypotheses using previously unheard of amounts of data, especially if that data includes the information on the learners’ L1, the context for the data collection, the task or activity setting (i.e., whether the activity was timed or untimed, planned or unplanned), the background information such as developmental level, the time spent in an L2 speaking country, or the learning context (i.e., the amount of exposure to L2 in the learners’ native countries). Partnerships between second language researchers and corpus linguists would facilitate the comparison of learner data with native data (L2 vs. L1) – for example,

researchers could focus on the errors found in learner corpora, focusing perhaps on under- and over-suppliance in obligatory contexts, i.e., aspects of language that can be measured against native speaker baseline data (McEney and Xiao 2011). Another research direction would be to conduct large-scale comparisons of different types of learner data (L2 vs. L2).

There is also a growing consensus that the field could benefit from strengthening the training of future researchers in the areas of statistics and research design. Loewen et al. (2014) recently surveyed both doctoral students and professors in the fields of applied linguistics and second language acquisition. The researchers found that only 14% of the doctoral students and 30% of the professors believed that their training in statistics had been adequate, leading them to recommend that training in statistics be strengthened. The AAAL subcommittee on improving research quality has also recommended that more focused efforts be placed on training graduate students in statistics and research design.

By expanding our research repertoire to make use of split-method approaches, by exploring new ways of conducting large-scale data analyses and by bolstering the training of future researchers in the areas of statistics and research design, the field of SLA will continue its growth and its ability to enrich our understanding of the human mind, social interactions, and second and foreign language pedagogy.

---

## Cross-References

- ▶ [Censuses and Large-Scale Surveys in Language Research](#)
- ▶ [Ethnography and Language Education](#)
- ▶ [Theoretical and Historical Perspectives on Researching the Sociology of Language and Education](#)

---

## References

- Abbuhl, R., Gass, S., & Mackey, A. (2013). Experimental research design. In R. Podesva & D. Sharma (Eds.), *Research methods in linguistics* (pp. 116–134). Cambridge: Cambridge University Press.
- Abu-rabia, S., & Kehat, S. (2004). The critical period for second language pronunciation: Is there such a thing? *Educational Psychology, 24*, 77–97.
- Biedroń, A., & Szczepaniak, A. (2009). The cognitive profile of a talented foreign language learner: A case study. *Psychology of Language and Communication, 13*, 53–71.
- Brown, J. (2011). Quantitative research in second language studies. In E. Hinkel (Ed.), *Handbook of research in second language teaching and learning* (Vol. 2, pp. 190–206). New York: Routledge.
- Cunnings, I. (2012). An overview of mixed-effects statistical models for second language researchers. *Second Language Research, 28*, 369–382.
- Dörnyei, Z. (2007). *Research methods in applied linguistics*. Oxford: Oxford University Press.
- Duff, P. (2008). *Case study research in applied linguistics*. Mahwah: Lawrence Erlbaum.
- Dulay, H., & Burt, M. (1974). Natural sequences in child second language acquisition. *Language Learning, 24*, 37–55.

- Gass, S. (2009). A historical survey of SLA research. In W. Ritchie & T. Bhatia (Eds.), *The new handbook of second language acquisition* (pp. 3–28). Bingley: Emerald.
- Granena, G., & Long, M. (2013). Age of onset, length of residence, language aptitude, and ultimate L2 attainment in three linguistic domains. *Second Language Research*, 29, 311–343.
- Grotjahn, R., & Kasper, G. (1991). Methods in second language research: Introduction. *Studies in Second Language Acquisition*, 13, 109–112.
- Hashemi, M., & Babaii, E. (2013). Mixed methods research: Toward new research designs in applied linguistics. *The Modern Language Journal*, 97, 828–852.
- Hatch, E., & Farhady, H. (1982). *Research design and statistics for applied linguistics*. Rowley: Newbury House.
- Language Teaching Review Panel. (2008). Replication studies in language learning and teaching: Questions and answers. *Language Teaching*, 41, 1–14.
- Lardiere, D. (2006). *Ultimate attainment in second language acquisition: A case study*. New York: Routledge.
- Larson-Hall, J. (2010). *A guide to doing statistics in second language research using SPSS*. London: Routledge.
- Larson-Hall, J., & Herrington, R. (2010). Improving data analysis in second language acquisition by utilizing modern developments in applied statistics. *Applied Linguistics*, 31, 368–390.
- Loewen, S., & Gass, S. (2009). The use of statistics in L2 acquisition research. *Language Teaching*, 42, 181–196.
- Loewen, S., Lavolette, E., Spino, L., Papi, M., Schmidtke, J., Sterling, S., & Wolff, D. (2014). Statistical literacy among applied linguists and second language acquisition researchers. *TESOL Quarterly*, 48, 360–388.
- Long, M. (2006). *Problems in SLA*. Mahwah: Lawrence Erlbaum.
- Mackey, A., & Gass, S. (2012). *Research methods in second language acquisition: A practical guide*. Oxford: Wiley-Blackwell.
- Marsden, E., & Mackey, A. (2014). IRIS: A new resource for second language research. *Linguistic Approaches to Bilingualism*, 4, 125–130.
- McEnery, T., & Xiao, R. (2011). What corpora can offer in language teaching and learning. In E. Hinkel (Ed.), *Handbook of research in second language teaching and learning* (Vol. 2, pp. 364–380). New York: Routledge.
- Plonsky, L. (2013). Study quality in SLA: An assessment of designs, analyses, and reporting practices in quantitative L2 research. *Studies in Second Language Acquisition*, 25, 655–687.
- Plonsky, L., Egbert, J., & Laflair, G. (2015). Bootstrapping in applied linguistics: Assessing its potential using shared data. *Applied Linguistics*, 36, 591–610.
- Polio, C. (1997). Measures of linguistic accuracy in second language writing research. *Language Learning*, 47, 101–143.
- Porte, G. (2010). *Appraising research in second language learning: A practical approach to critical analysis of quantitative research*. Amsterdam: John Benjamins.
- Porte, G. (2012). *Replication research in applied linguistics*. New York: Cambridge University Press.
- Richards, K. (2003). *Qualitative inquiry in TESOL*. New York: Palgrave Macmillan.
- Richards, L., & Morse, J. (2007). *Readme first for a user's guide to qualitative methods*. Thousand Oaks: Sage.
- Sheen, Y. (2010). Differential effects of oral and written corrective feedback in the ESL classroom. *Studies in Second Language Acquisition*, 32, 203–234.

---

# Methods in Multilingualism Research

Beatriz Lado and Cristina Sanz

---

## Abstract

This chapter presents an overview of research conducted on multilingual language acquisition (i.e., third language (L3) and additional language learning) with an emphasis on its methodological design. Early research developments in the field of multilingual language acquisition focused on the role of prior language experience on subsequent language learning with studies conducted in laboratories and in bilingual programs. Recent contributions to the field include studies that explore crosslinguistic influence (CLI) from different perspectives (e.g., universal grammar [UG], psycholinguistics, functional linguistics). Additionally, laboratory studies such as *The Latin Project* have investigated the interaction between prior linguistic knowledge and learning conditions and include cognitive variables (e.g., attentional control and working memory capacity) as possible moderating variables. Quantitative cross-sectional studies are common under these approaches, but qualitative analyses are often included to provide a larger picture of the results obtained. This is also the nature of a recent holistic approach to multilingualism (e.g., Cenoz and Gorter *Mod Lang J* 95(3): 339–343, 2011), which focuses on the connections among the different languages of the learner. Promising work in progress is exploring the effects of language experience on subsequent language learning with online measures of neurocognitive processing (e.g., Grey A neurocognitive investigation of bilingual advantages at additional language learning. Unpublished doctoral dissertation. Georgetown University,

---

B. Lado (✉)

Department of Languages and Literatures, Lehman College and The Graduate Center (CUNY),  
New York City, NY, USA

e-mail: [beatriz.lado@lehman.cuny.edu](mailto:beatriz.lado@lehman.cuny.edu)

C. Sanz (✉)

Department of Spanish and Portuguese, Georgetown University, Bunn Intercultural Center,  
Washington, DC, USA

e-mail: [sanzc@georgetown.edu](mailto:sanzc@georgetown.edu)

Washington, DC, 2013). Also, longitudinal studies with schooled children and college students in bilingual areas (e.g., Catalonia and Basque Country in Spain) are trying to understand how instructional conditions affect subsequent language learning and how individual differences such as motivation interact with the effects observed. The last two sections of the chapter present problems that researchers may encounter in relation to sample, constructs, measurements, and analyses in conducting research on multilingual language acquisition. The chapter concludes with suggestions for future research in this area.

---

### Keywords

Multilingual development • Methods • Language experience • Longitudinal and cross-sectional research

### Contents

Introduction .....	196
Early Developments .....	197
Major Contributions .....	199
Work in Progress .....	208
Problems and Difficulties .....	209
Future Directions .....	211
Cross-References .....	212
Related Articles in the Encyclopedia of Language and Education .....	212
References .....	212

---

### Introduction

The term *Multilingualism* has often been used to define individuals or societies that rely on more than one language to communicate. In the present chapter, the term *multilingualism* refers to multilingual acquisition, that is, the acquisition of an L3 and/or any additional language (Ln). Research methods in multilingual development adopt different perspectives to address questions about acquisition processes and products, their educational and social contexts, as well as the individual variables involved.

As the field only started in the late 1980s, the methodology is innovative and highly eclectic, with designs borrowed both from linguistics and psychology by way of second language acquisition (SLA) and educational research. Quantitative, hypothesis-testing studies still outnumber qualitative or question-generating designs, although recent dynamic approaches tend to include both qualitative and quantitative data. In this regard, mixed designs combining description and interpretation with descriptive and even inferential statistics are also common. Data are collected both longitudinally and cross-sectionally, most often elicited by means of questionnaires, tests, and interviews and from large samples in tutored contexts. However, studies on experimental interventions that incorporate elicitation tasks are growing. The most popular quantitative procedures include analyses of variance (ANOVA), correlations, and regressions, but the last 5 years have seen an increase in publications that

include linear growth analysis to investigate systematic change and interindividual variability in this change.

---

## Early Developments

Despite living in an age of migration and supranational entities, it was not until late in the twentieth century that multilingualism was recognized as the norm rather than the exception. Beginning in the 1960s, changes in general attitudes toward minorities led to greater recognition of language rights and needs of minority populations, sometimes resulting in the development of educational policies that address such rights. Increased communication between European and American researchers, as evident in, for instance, the International Conference on Third Language Acquisition and Multilingualism or the multiple publications coming from both sides of the Atlantic in professional journals and in *Multilingual Matters* (e.g., Cenoz and Gorter 2011; Sanz et al. 2014), is also responsible for the growing interest in multilingualism and language acquisition beyond the L2.

In the context of these shifts, a new focus on the relationship between bilingualism and cognition led to laboratory research investigating the role of prior experience on the acquisition of an L3 (McLaughlin and Nayak 1989; Nation and McLaughlin 1986; Nayak et al. 1990). Multilingual subjects (1) were found to habitually exert more effort when processing verbal stimuli, (2) were better able to shift strategies to restructure their language systems, and (3) used cognitive processing strategies that facilitated the construction of formal rules. The designs of these studies are characteristic of the cognitive framework to which they belong, in that they are experimental and compare the effects of highly controlled, computer-generated treatments on the acquisition of an artificial grammar. Conclusions are based on results from ANOVAs and post hoc analysis on accuracy and latency data.

From a Chomskyan approach, but also process oriented in nature, Klein's investigation (1995) of the acquisition of the preposition-stranding parameter by English as a second language (ESL) learners shows that multilinguals and monolinguals produce the same type of errors, but multilinguals learn faster because they more efficiently identify the key verbs that trigger the parameter. This result indicates that prior language experience promotes noticing of key elements in the input.

The establishment of immersion programs in Canada and later in Europe led to another series of product-oriented studies. This work aimed to provide insight into appropriate timing and procedures for the incorporation of foreign languages (L3s) into bilingual curricula, to properly document the development of different types of immersion programs, and to investigate the underlying psychosocial variables involved. Cenoz and Valencia's (1994) comparison of English proficiency among students instructed in the minority (Basque) or majority language (Spanish) yielded evidence in favor of bilingualism and bilingual education as

contributors to L3 learning, independent of cognitive, sociostructural, sociopsychological, and educational variables, as well as independent of the first language (L1). Sanz (2000) compared L3 (English) acquisition of bilingual Catalan/Spanish in a Catalan immersion program with monolinguals from a Spanish region with parallel results. In turn, Swain et al. (1990) investigated the effect of L1 literacy on L3 (French) learning in Toronto and found that knowledge of a heritage language had little facilitative effect on L3 acquisition without L1 literacy. Their conclusions supported Cummins' (1981) linguistic interdependence hypothesis, according to which children learn to use language as a symbolic system while acquiring literacy skills in their first language. As a result, learners are able to generalize linguistic information in a way that can be transferred to subsequent language learning contexts. However, counterevidence for this relationship also exists. Wagner et al.'s (1989) study of Berber and Arab children in Morocco concluded that L1 literacy is not necessary to achieve native-like literacy norms in Arabic or French.

A possible explanation for the seemingly contradicting effects is the status of the languages involved; indeed, socioeducational variables are likely an important component of L3 acquisition. For this reason, more research within different sociolinguistic contexts is important (e.g., Lambert 1981). One challenge in making cross context comparisons, however, is the striking methodological differences across multilingualism research. For instance, Wagner et al. (1989) conducted a 6-year longitudinal study examining primary school literacy in three languages, whereas others (e.g., Cenoz and Valencia 1994; Sanz 2000; Swain et al. 1990) used cross-sectional designs with a focus on general linguistic ability and included older participants. Despite their differences, these designs are characterized by their product-oriented nature, including large sample sizes; complex batteries of attitudinal, motivational, and background questionnaires; nonlanguage-based IQ tests; attention to language knowledge and use patterns; and a preference for correlations and regressions. Importantly, they overcome the methodological limitations that plagued research prior to the 1960s, when socioeconomic status, intelligence, and bilingualism were usually confounded.

A decade ago, Multilingual Matters press published several volumes that provided an overview of the sociolinguistic, psycholinguistic, and educational aspects of L3 learning (e.g., Cenoz et al. 2001a; Mayo and Lecumberri 2003). Cenoz et al. (2001a) published a collection of empirical studies on crosslinguistic influence (CLI), which explored the role of psycholinguistic factors such as linguistic distance, competence, age of acquisition, recency, amount of formal instruction and frequency, and contextual use of the languages involved. Mayo and Lecumberri (2003) presented empirical studies on the age factor, a line of research that was followed by the Grup de Recerca en Adquisició de Llengües (GRAL, <http://www.ubgral.com/>) at the University of Barcelona and the Research in English and Applied Linguistics (REAL) Group in the University of the Basque Country. The longitudinal studies conducted by these two research groups revealed that an earlier age of first exposure to a third language does not result in higher performance as older learners may benefit from cognitive maturation. The authors of these studies also



believe the quality of language instruction to be responsible for the lack of advantage for early exposure.

---

## Major Contributions

In the last 10 years, the number of publications on multilingual development has continued to grow. The International Association of Multilingualism and the abovementioned International Conference on Third Language Acquisition and Multilingualism have provided a platform for the distribution of research carried out under different approaches. Although *Multilingual Matters*, supported by the association, is still the most important press for volumes on multilingualism research (e.g., De Angelis and Dewaele 2011), other presses such as John Benjamins (e.g., Cabrelli Amaro et al. 2012) or Springer (e.g., Gabrys-Barker 2012) have also published volumes on L3 and multilingual language acquisition. The following section presents a brief summary of these volumes. Methodological details – including sample, languages, materials, analysis, and conclusions – are provided in Table 1. Overall, it seems that although most research still adopts either a qualitative or a quantitative approach, more studies are including both types of analyses as a way to account for the complex nature of language development in multilinguals. In terms of sample, as in earlier research, college and high school students are the most represented populations, although the presence of older adults and senior citizens in a few of these studies reveals a growing trend. Finally, the majority of studies reported in these volumes are conducted in bilingual countries where English is the most popular foreign language. For that reason, it is understandable that English appears as the most frequent L2 or L3. Spanish and German follow English and seem to have a similar presence. Interestingly, these volumes include languages as disparate as Cantonese, Polish, Tuvan, or Georgian, which were not present in traditional L3 research.

The volume edited by De Angelis and Dewaele (2011) (code 1 in Table 1) includes seven studies devoted mainly to CLI in relation to, among other factors, affordances, backward transfer, *L2 status factor* (Bardel and Falk 2007), or the role of metalinguistic awareness in multilingual acquisition. The study of the intricacies of previous language experience on L3 phonology is becoming a promising line of research as revealed by its presence not only in this volume but also in Cabrelli Amaro et al. (2012) (code 2 in Table 1). Both studies find that the L1 seems to have a prevailing influence on L3 phonology.

Pragmatics is another emergent field in the study of multilingual acquisition. Gabrys-Barker's (2012) (code 3 in Table 1) edited volume reports on two studies in this area that reveal a positive CLI among the languages involved. Other works of Cabrelli Amaro et al. (2012) and Gabrys-Barker (2012) include empirical studies conducted under a UG approach and test the models developed to explain CLI. Besides the *L2 status factor*, the models tested are the *cumulative enhancement model* (CEM), first proposed by Flynn et al. (2004), the *typological primacy model* (TPM) (Rothman 2011), or the *full transfer/full access hypothesis* (Schwartz and

**Table 1** Overview of studies in (1) De Angelis and Dewaele (2011), (2) Cabrelli Amaro et al. (2012), and (3) Gabryrs-Barker (2012)

Study	Goal	Sample	Languages involved	Tests/materials	Analysis	Conclusions
Angelovska and Hahn (3)	To investigate negative transfer (L2 to L3) at various L3 proficiency levels	$N = 13$ (aged 20–25)	Different L1s German (L2) English (L3)	Oxford Quick Placement Test Free written production text	<i>Qualitative:</i> Percentage of L2-negative transfer instances (overall and per L3 level) and description of type of instances transferred <i>Contrastive analyses</i> of languages involved	Support for <i>L2 status factor</i> Transfer of L2 syntactical properties that do not exist in the L1
Berkes and Flynn (2)	To test the CEM and to investigate the effect of the last learned L2 on L3 complementizer phrase development	$N = 78$ (college and high school students)	Hungarian (L1) German (L1/L2) English (L2/L3)	Michigan test Elicited imitation task on the production of English relative clauses	<i>Quantitative:</i> Three-way ANOVA, paired samples <i>t</i> -test, and correlations	Support for the CEM Increased facilitation in subsequent acquisition with each new language learned Development of syntactic knowledge that cannot be explained as transfer from the last language learned
Berkes and Flynn (3)	To investigate what CEM predicts when language proficiency is controlled	$N = 72$ (high school students)	Hungarian (L1) German (L2) English (L2/L3)	Michigan test Elicited imitation task on the production of English relative clauses	<i>Quantitative:</i> Three-way ANCOVA	New syntactic knowledge acquired as adult “rearranges the UG-guided language development”

Bono (1)	To investigate the role of native and nonnative languages (proximity, proficiency, L2 status, etc.) and the role of metalinguistic awareness in the L3 learning process	N = 42 (college students)	French (L1) English (L2) Different L3s and L4s	Forty-eight 30 min recordings of uncontrolled speech production	<i>Qualitative:</i> Classification of language switches according to functional typology and description of metalinguistic sequences	Support for L2 status factor Evidence of higher levels of metalinguistic awareness in multilinguals
Cheung, Matthews, and Tsang (1)	To investigate the role of backward language transfer (L3 to L2) in the acquisition of the present perfect past simple contrast in L2 English	N = 37 (college students)	Cantonese (L1) English (L2) German (L3)	Writing task Acceptability judgment task	<i>Qualitative:</i> Frequency and percentages of nontarget use <i>Quantitative:</i> Independent samples t-test	Support for backward transfer
Dewaele (2)	To investigate the role of individual differences in self-perceived proficiency (SPP) in multilinguals	N = 122 (aged 15–65)	Spanish (L1/L2) Galician (L1/L2) English (L3/L4) French (L3/L4) Different Lns	Questionnaire	<i>Quantitative:</i> Several statistical tests (Mann-Whitney, correlations, etc.)	SPP was found to be linked to different variables (e.g., age of onset, language attitudes) for most languages (not for Spanish)
Elordi (3)	To investigate how CLI affects learning of the French and Spanish subjunctive when mood can alternate without ungrammaticality	N = 101 (adults)	French (L1/L2) Spanish (L1/L2/L3) English (L1)	Scenario selection task	<i>Quantitative:</i> ANOVAs	Multilingual learners outperformed monolinguals Positive CLI from L2 to L3 (stronger) and from L3 to L2

(continued)

Table 1 (continued)

Study	Goal	Sample	Languages involved	Tests/materials	Analysis	Conclusions
Karpava, Grohmann, and Fokianos (3)	To investigate different areas of Greek (L2/L3) acquisition in the domain of aspectual marking in embedded clauses	N = 132 (adults and children)	Georgian (L1)	Two-task test	<i>Qualitative:</i> Comparison among groups of percentages of nontarget production  <i>Quantitative:</i> Analyses of deviance and multiple comparison analyses for origin and age levels	Support for <i>full transfer/full access hypothesis</i> L2 learners can reach native-like attainment, though there is L1 interference at the initial stage of L2 acquisition
			Russian (L1/L2)	Forced-choice task		
			Greek (L2/L3)	Elicited production task		
Kresić and Gulan (3)	To investigate the role of interlingual identifications, learner's psychotopology, and learner's proficiency with respect to modal particles/modal elements	N = 148 (college students)	Croatian (L1)	<i>Four tasks:</i> Mapping of equivalents, filling in gaps, translations, and assessment of similarities	<i>Quantitative:</i> T-tests for independent and dependent samples Correlations	Interlingual identifications are facilitative of multilingual language learning
			English (L2/L3)			
			German (L2/L3)			
Kulundary and Gabriele (2)	To investigate the role of L2 syntactic development in L3 acquisition (comprehension of coordinate and relative clauses)	N = 152 (high school and college students)	Russian (L1/L2)	Michigan Listening Comprehension Test	<i>Quantitative:</i> One-way ANOVA and repeated-measures ANOVA	Better performance in L2 Russian led to better performance on L3 English coordinate clauses, but not on relative clauses
			Tuvan (L1)	Two comprehension tests		
			English (L2/L3)			

Jaensch (2)	To test the CEM, <i>L2 status/factor</i> , and TPM theories while investigating the effect of the L1 and of general L2 proficiency on L3 German gender assignment, gender concord on articles and adjectives, and definiteness on articles	N = 26 (aged 15–32)	Japanese (L1) Spanish (L1) English (L2) German (L3)	Gender assignment task Definiteness and gender concord on articles task Gender concord on articles task	<i>Quantitative:</i> Non-parametric tests	Positive effect of L2 proficiency on L3 development Results provide support for the <i>L2 status/factor</i> and the TPM (although not on gender assignment to novel Ns)
Lindqvist (2)	To investigate word choices in native speakers and two levels of nonnative speakers of French (low-intermediate and advanced) and if there is CLI between languages	N = 29 (PhD and secondary school students)	Swedish (L1) English (L2) German (L2/Ln) Italian (L2/Ln) Spanish (L2/Ln) Russian (L2/Ln) Latin (L2/Ln) French (L3/Ln)	Retelling of two short video films	<i>Qualitative:</i> Description of word choices used by native and nonnative	Advanced learners preferred more general words than native speakers Advanced learners have more meaning-based CLI; low-intermediate learners have more formal CLI

(continued)

Table 1 (continued)

Study	Goal	Sample	Languages involved	Tests/materials	Analysis	Conclusions
Odlin (3)	To investigate acquisition of zero prepositions and articles in L2 and L3	N = 210 (aged 11–16)	Finish (L1)	Writing piece (film retell)	<i>Qualitative:</i> Total occurrence of articles and prepositions in writing of each participant	Learners with Swedish language experience performed better on English prepositions but similarly on L3 articles
			Swedish (L1/L2)			
			English (L2/L3)		<i>Quantitative:</i> Summary of group tendencies (quantitative statistical tables provided in Odlin 2012)	
Otwińska-Kasztelanic (1)	To investigate the link between affordances available to language learners and their awareness of crosslinguistic lexical similarities	N = 512 (aged 19–35)	Polish (L1)	Questionnaire	<i>Qualitative:</i> Percentages and description of comments	Multilingual learners have more affordances (perceived opportunities for action) than bilinguals
			English (L2)			
			Different L3s and L4s			
Pinto and Carvalhosa (3)	Investigate the role of CLI in L3 production	N = 37 (college students)	Serbian (L1)	Dictation task	<i>Qualitative:</i> Number and examples of nonproduced words, spelling errors, and CLIs	Influence of languages typologically closer to the L3
			Different L2s			
			Portuguese (L3)			

Safont-Jordà (3)	To explore the role of the L1, L2, and L3 on pragmatic development in request modification items in a case study	A 2-year-old child	Catalan (L1) Spanish (L2) English (L3)	Audio and video recordings of mother-child interaction during a year	<i>Qualitative:</i> Instances of the child's production (request modifiers) <i>Quantitative:</i> Wilcoxon signed-rank test and Friedman test	The three languages interact and modify one another  Evidence of identification of early pragmatic differentiation
Sanchez (1)	To explore if the L2 <i>status factor</i> affects transfer more than typological distance during ab initio English (L4) learning	N = 154 children (aged 8.9–10.9)	Spanish (L1/L2) Catalan (L1/L2) German (L3) English (L4)	Story telling task ( <i>The Dog Story</i> )	<i>Qualitative:</i> Description of data <i>Quantitative:</i> Pearson correlations on internal consistency	Support for the role of all nonnative languages on L4 irrespective of typology
Tymczyńska (3)	To investigate the impact of conference interpretation training and practice on the strength of interlingual lexical links in the mental lexicons of trilinguals	N = 26 (average age 35.4)	Polish (L1) English (L2) German (L3)	Translation judgment test	<i>Quantitative:</i> Paired samples t-tests, multivariate tests, and ANOVAs	Expertise in conference interpretation associated with better accuracy and ability to process semantic information, but not with faster lexical retrieval in translation tasks

(continued)

Table 1 (continued)

Study	Goal	Sample	Languages involved	Tests/materials	Analysis	Conclusions
Wlosowicz (3)	Three studies on the role of CLI at the grammatical level in reception and production of L3	$N = 152$ (study 1)	Different L1s, L2s, and L3s (Polish, English, French, German, and Portuguese)	Translation of tests from L3 into L1 while thinking aloud (study one)	<i>Qualitative:</i> Description of examples and percentages of responses attributable to different sources	Transfer to the L3 occurs from the L1 and the L2
		$N = 21$ (study 2)				
		$N =$ (study 3) (adults)				
Wrembel (2)	To investigate L1- or L2-accented speech in learners' L3 and its relationship to L3 proficiency level	$N = 11$ (college students)	Polish (L1)	Read on your own task	<i>Quantitative:</i> Statistical procedures (t-tests, ANOVAs) established relationships between proficiency level and accent ratings from 20 judges	Prevailing influence of the L1 on L3 phonology irrespective of L3 level
			French (L2)	Spontaneous speech task		
			English (L3)			
Wunder (1)	Role of CLI on L3 phonology	$N = 8$ (adults)	German (L1)	Two read-on-your own tasks	<i>Qualitative:</i> Recordings analyzed with Praat for <i>voice onset time</i> (VOT) (means and percentages)	Stronger role of the L1 (over the L2) on the amount of L3 aspiration
			English (L2)	Praat (Boersma and Weenink 2015)		
			Spanish (L3)			



Sprouse 1996). Overall, these studies revealed mixed results for the CEM and gave an important role to the L2 when learning an L3.

As reflected in the volumes above, the study of CLI continues to grow in different contexts and with different populations with results that point toward complexity and multidirectionality. Many of the studies reviewed in these volumes adopt a UG approach, but recent accounts have also used other frameworks such as the *competition model* (CM) (MacWhinney and Bates 1989) to explore CLI. Specifically, Sanz et al. (2014) examined the role of L1 (English) and L2 (Japanese and Spanish) in ab initio development of L3 (Latin) morphosyntax. Their results indicate that during the first stages of L3 language processing, L1 plays a larger role and that higher levels of L2 are needed for integrated patterns of L1 and L2 cues to emerge.

Sanz et al. (2014) is one of many studies coming out of *The Latin Project*, a research program that investigates the interaction between language experience and input varying in degrees of explicitness, and includes cognitive variables such as aptitude as possible moderating variables. The target is the use of word order, case, and number morphology in the assignment of semantic functions (or who does what to whom) in L3 Latin by native speakers of different L1s (English, Spanish, Chinese) and L2s (English, Spanish, Japanese, Arabic). The project contributes to the growing line of research suggesting that prior linguistic experience provides bilinguals with cognitive abilities that facilitate additional language learning.

The different conditions in *The Latin Project* vary in their degree of complexity depending on the amount of metalinguistic information provided as it looks for a possible interaction between bilingualism and task conditions (e.g., Bialystok 2001). Departing from previous studies that compared monolinguals with bi-/multilinguals, *The Latin Project* delves into the role of prior experience on additional language learning by including bilinguals with different degrees of proficiency in their non-primary languages. Stafford et al. (2010) compared early and late bilinguals through exposure to a highly explicit condition – a treatment consisting of a grammar lesson and task-essential practice with metalinguistic feedback. While the groups performed similarly on the immediate posttests, late bilinguals were better at retaining what they had learned 3 weeks after the treatment. *The Latin Project* has also incorporated an often underrepresented population (e.g., adults who were older than 65 years old) in multilingual acquisition research. Cox and Sanz (2015) investigated the effects of explicit instruction and practice in two groups of late English/Spanish bilinguals aged over 65 years old and aged between 19 and 27. The results revealed that younger bilinguals benefit more than older adults from explicit instruction alone and maintain this advantage in interpretation tasks after practice. Importantly, the young adults' advantage was not maintained 3 weeks after the treatment. The studies in *The Latin Project* rely on ANOVAs, ANCOVAs, and linear growth analyses to analyze accuracy and latency data elicited by means of aural and written interpretation tasks, grammaticality judgment tasks, and production tasks. The studies are entirely computer delivered, thanks to a software application that combines Flash and ColdFusion tools; the application can be accessed online and delivers all audiovisual materials, collects all data, and stores it facilitating password-protected access to the procedures and the database.

A different paradigm is advocated by scholars such as Cenoz and Gorter (2011), who have proposed a holistic approach to second (and additional) language learning to better account for the complex nature of the language acquisition process. This approach stems from recent dynamic approaches to second (and additional) language acquisition such as the *dynamic systems theory* (De Bot et al. 2007) and explores the connections and interactions of the different languages of the learner as well as the way in which these languages support each other. An example of a study conducted within this approach is the case study by Safont-Jordà (see Table 1). Cenoz and Gorter (2011) also used this approach to compare writing samples of bilingual (L1/L2 Spanish/L1/L2 Basque) teenagers with English as L3. Correlations were obtained for each pair of languages for most of the dimensions evaluated (content, structure, vocabulary, grammar, and mechanics). Additionally, their quantitative and qualitative analyses looked at scores in each of the languages separately and at instances of transfer. The results revealed multidirectional crosslinguistic influence and nonlanguage differences in general writing strategies.

---

## Work in Progress

New investigations are implementing online measures of neurocognitive processing as potential tools to understand the way previous language experience influences additional language learning. This approach (i.e., electrophysiology) records electrical voltage potentials produced by cellular activity, which can later be analyzed and can yield patterns of data called event-related potentials (ERPs). These ERPs provide information on timing and nature of processing (see Morgan-Short 2014, for more information on language acquisition ERP research). Grey's (2013) recent dissertation is the first study to compare bilinguals and monolinguals using models and tools from neurocognition. The study compared early balanced Mandarin-English bilinguals to monolinguals learning a Romance language-like (Brocanto2). Participants were exposed to an instructed (with metalinguistic information and meaningful examples) or uninstructed (with meaningful examples and no metalinguistic information) condition at two different points (low and high experience). Grey's behavioral (accuracy) results did not show marked differences between bilinguals and monolinguals; however, ERP data revealed differential reliance on neurocognitive mechanisms at different points in the learning curve for bilinguals and monolinguals.

The GRAL group continues to conduct longitudinal studies on the role of age, input, and aptitude as predictors of L3 (English) proficiency by Catalan/Spanish bilinguals. This group has investigated L2 and L3 development in study abroad (SA) contexts with children, adolescents, and adults in quantitative projects that compare short-term SA (2/3 months or 3 weeks) with immersion English as a foreign language (EFL) courses at home. Their findings reveal that after 3 months in a SA context, learners outperform those at home regardless of age. Additionally, comparable performance between SA and EFL groups was found for the 3-week period,

although the SA learners had an advantage in one of the areas investigated (formulaic sequences and lexical complexity).

Study (or stay) abroad and language acquisition is also one of the main foci of the SALA project (at Universitat Pompeu Fabra in Barcelona and Universitat de les Illes Balears in Palma de Mallorca, [http://www.upf.edu/allencam/en/research\\_projects/sala.html](http://www.upf.edu/allencam/en/research_projects/sala.html)), with comparable work on the effects of different learning contexts (SA and formal instruction, FI) on the development of English as an L3 by Catalan/Spanish bilingual college students (Pérez Vidal 2014). The project is quantitative and longitudinal and investigates the interaction between context of acquisition and individual differences. Data is rich: immediate and retention gains in L3 oral comprehension and production, grammatical abilities, phonological perception and written production. In line with some of the findings of the GRAL group, the results point toward a positive effect of SA not only in oral but also in written abilities. Phonological development, on the contrary, does not seem to be affected by SA. This research group has expanded its scope of investigation in the COLE project by including teenagers and both quantitative and qualitative data to compare FI with *content and language integrated learning* (CLIL) in English, which has resulted in a compilation of studies that have appeared in a volume edited by Juan-Garau and Salazar-Noguera (2015). Similar research is being conducted in another bilingual area in Spain by the Language and Speech Laboratory (LASLAB) at the University of the Basque Country, including longitudinal studies comparing English as a foreign language (EFL) versus CLIL in an attempt to find effective ways to develop L3 English communicative competence in school contexts. In particular, this team has conducted research on the acquisition of L3 English from a generative perspective with a focus on morphosyntactic development. Cognitive and psychopedagogic approaches are also adopted to incorporate the study of individual differences (e.g., motivation) and how they influence the effect of instructional contexts on L3 development. Work completed links CLIL with higher motivation and more positive language outcomes.

To conclude, in the last 10 years, the field has started to incorporate different contexts (e.g., SA, CLIL) in an attempt to understand how external conditions interact with individual differences and bilingualism to explain L3 development. These studies are often longitudinal and collect qualitative and/or quantitative data. In addition, laboratory studies continue to provide more information on the actual processes involved in multilingual acquisition by manipulating external conditions and collecting data with different techniques, including those borrowed from neurocognition.

---

## Problems and Difficulties

Multilingual language acquisition is complex and its investigation requires sophisticated designs. The challenges are many, stemming from four basic components of the design: sample, constructs, measurements, and analyses.

In order to answer some of the questions, especially those that require multifactorial, correlational types of analyses, researchers need to identify large, homogeneous samples. This is no easy task because such participants are not always available or willing. For example, schooled children and college students are usually available to researchers. However, other populations such as older adults are not so easy to reach.

In addition, institutional review boards make it difficult to include certain items in questionnaires or certain conditions in the design, citing the potential for lawsuits concerning discrimination based on gender, race, or place of origin, all of which provides another reason to explain the limits in the proportion of minorities in samples. Finally, obtaining a homogeneous sample, especially in terms of proficiency, frequency of use, and age of acquisition of the languages involved is a major achievement in and of itself.

Most constructs, including motivation, aptitude, and awareness, are elusive, difficult to define, operationalize, and measure. It is often necessary to reformulate the tests and recode and revise the procedures after a discussion among raters to avoid inter-rater reliability problems. The inclusion of certain procedures, for example, requiring learners to think aloud while completing a treatment in order to measure awareness, might turn against the researcher by altering the very same processes under investigation (reactivity) (e.g., Sanz et al. 2009).

In addition, the construct Ln *proficiency* is especially problematic both because it assumes a standard variety and because it includes a multiplicity of elements (e.g., oral and written productive and receptive skills). Furthermore, multilinguals' Ln proficiency is often measured with tests that are designed for monolinguals, which are not sufficiently fine grained to evaluate highly skilled multilinguals. Other studies measure proficiency with self-rated questionnaires without considering that learners' ratings may be influenced by different factors (e.g., attitude toward the language).

Naturally, because constructs are hard to define, measurements also suffer. A classic example is the Modern Language Aptitude Test (MLAT), a measure of aptitude to learn nonnative languages. Aptitude is actually a macroconcept made up of four smaller constructs (phonetic coding ability, rote learning ability, grammatical sensibility, and inductive language learning). Due to its multicomponential nature, any results associated with higher or lower aptitude do not actually inform us about the specific microconstruct which ultimately accounts for the results. New aptitude tests such as the LLAMA Language Aptitude Test (Meara 2005) or the Cognitive Ability for Novelty in Acquisition of Language – Foreign (CANAL-F) Grigorenko et al. (2000) incorporate measures of constructs that have not been considered in the MLAT (e.g., working memory, attentional processing). Additionally, recent reevaluations of the construct recognize the role of affective factors (strategy use and motivation) as mediating factors on the role of aptitude on language learning (Winke 2013).

Regressions and correlations are frequent procedures in quantitative studies because Ln acquisition and use is multifactorial and demands an interactive approach, which leads to several problems. First, it demands large samples. Also,

while these analyses clearly establish relationships among the factors, the direction of the relationship is left to interpretation. Moreover, a relationship does not imply cause and effect. Finally, the variety of methods implemented and the lack of replication are a challenge for any scholar trying to draw general conclusions for the research (Sanz 1997).

---

## Future Directions

Multilingual language acquisition is a relatively new field that will no doubt grow in breadth and depth as it strives to isolate the internal and external variables involved in L<sub>n</sub> learning and to account for their multiple interactions. Methods will expand to include research on the acquisition of non-primary languages in formal contexts, case studies, and laboratory research as scholars continue to borrow and refine methods from linguistics, sociology, and psychology and to create their own.

Qualitative and question-generating case studies will continue to grow, as they are necessary in a young field in which homogeneity in the sample is extremely difficult to achieve. An advantage of case studies is that they allow the learner's voice to be heard. To include the learners' reactions is a growing trend in language research in general, including laboratory research, resulting in mixed designs that combine highly controlled procedures with debriefing questionnaires and stimulated recalls, for example. As a result, a combination of micro-, macro-, and learner-centered designs will develop.

Future research will also need to continue developing research designs that account for the complex nature of multilingual acquisition. It is important to include measures and analysis that incorporate the variability and dynamics of the learner's languages (Herdina and Jessner 2002). An example is the study of motivation in language acquisition, which in the last decade has looked into the motivation process and its dynamic interaction with different internal and external factors. Many studies under this sociodynamic approach are conducted qualitatively with interviews (e.g., Ushioda 2001) and provide information on how motivation changes depending on the outcomes achieved. Research also needs to continue exploring whether language experience has an effect on language aptitude (e.g., Thompson 2013). Longitudinal studies with learners at different points in their language development should provide more evidence of the dynamic nature of both motivation and aptitude and of their role in subsequent language learning.

Finally, laboratory research within the cognitive framework will continue to increasingly implement computers in the design as more and larger laboratories become available, research institutions hire technicians, and software becomes more affordable. Computers allow for highly controlled treatments and data gathering procedures. Moreover, they allow researchers to track learners' performance, manipulate the amount and type of input presented, and even individually adapt it based on performance. They also facilitate the inclusion of reaction time – not just accuracy – data in the design, expanding our view of learners' performance. Theoretical developments in neurolinguistics, closely tied to advances in neuroimaging techniques,

although still in its infancy in multilingual acquisition research, will certainly continue to grow. This new line of research will contribute to our knowledge of internal factors, including individual differences, and their interaction with external factors, which is necessary to explain such a complex phenomenon as multilingual acquisition.

---

## Cross-References

- ▶ [Research Perspectives on Bilingualism and Bilingual Education](#)
- ▶ [Researching the Continua of Biliteracy](#)
- ▶ [Second Language Acquisition Research Methods](#)

---

## Related Articles in the Encyclopedia of Language and Education

Diana Schwinge: [Biliteracy and Multiliteracy in Bilingual Education](#). In Volume: Bilingual Education

James Cummins: [Teaching for Transfer in Multilingual School Contexts](#). In Volume: Bilingual Education

---

## References

- Bardel, C., & Falk, Y. (2007). The role of the second language in third language acquisition: The case of Germanic syntax. *Second Language Research*, 23(4), 459–484.
- Bialystok, E. (2001). *Bilingualism in development: Language, literacy, and cognition*. New York: Cambridge University Press.
- Boersma, P., & Weenink, D. (2015). Praat: Doing phonetics by computer [computer program]. Version 5.4.12, retrieved 10 Jul 2015 from <http://www.praat.org/>
- Cabrelli Amaro, J., Flynn, S., & Rothman, J. (2012). *Third language acquisition in adulthood*. Amsterdam: John Benjamins.
- Cenoz, J., & Gorter, D. (2011). A holistic approach in multilingual education: Introduction. [Special issue toward a multilingual approach in the study of multilingualism in school contexts]. *The Modern Language Journal*, 95(3), 339–343.
- Cenoz, J., & Valencia, J. F. (1994). Additive trilingualism: Evidence from the Basque Country. *Applied Psycholinguistics*, 15, 195–207.
- Cenoz, J., Hufeisen, B., & Jessner, U. (2001a). *Cross-linguistic influence in third language acquisition: Psycholinguistic perspectives*. Clevedon: Multilingual Matters.
- Cenoz, J., Hufeisen, B., & Jessner, U. (2001b). *Looking beyond second language acquisition: Studies in tri- and multilingualism*. Tübingen: Stauffenburg.
- Cox, J. G., & Sanz, C. (2015). Deconstructing PI for the ages: Explicit instruction vs. practice in young and older adult bilinguals. *International Review of Applied Linguistics in Language Teaching*, 53(2), 225–248.
- Cummins, J. (1981). The role of primary language development in promoting educational success for language minority students. In California State Department of Education (Ed.), *Schooling and language minority students: A theoretical framework* (pp. 3–49). Los Angeles: Evaluation, Dissemination, and Assessment Center, California State University.

- De Angelis, G., & Dewaele, J. M. (2011). *New trends in crosslinguistic influence and multilingualism research*. Bristol: Multilingual Matters.
- De Bot, K., Lowie, W., & Verspoor, M. (2007). A dynamic systems theory approach to second language acquisition. *Bilingualism: Language and Cognition*, 10, 7–21.
- Flynn, S., Foley, C., & Vinnitskaya, I. (2004). The cumulative enhancement model for language acquisition: Comparing adults' and children's patterns of development in first, second and third language acquisition of relative clauses. *International Journal of Multilingualism*, 1(1), 3–16.
- Gabrys-Barker, D. (2012). *Cross-linguistic influences in multilingual language acquisition*. Berlin/Heidelberg: Springer.
- García Mayo, M. P., & García Lecumberri, M. L. (2003). *Age and the acquisition of English as a foreign language*. Clevedon: Multilingual Matters.
- Grey, S. (2013). *A neurocognitive investigation of bilingual advantages at additional language learning*. Unpublished doctoral dissertation. Georgetown University, Washington, DC.
- Grigorenko, E. L., Stermer, R. J., & Ehrman, M. E. (2000). A theory-based approach to the measurement of foreign language ability: The canal-F theory and test. *The Modern Language Journal*, 84(3), 390–405.
- Herdina, P., & Jessner, U. (2002). *A dynamic model of multilingualism: Perspectives of change in psycholinguistics*. Clevedon: Multilingual Matters.
- Juan-Garau, M., & Salazar-Noguera, J. (2015). *Content-based language learning in multilingual educational environments*. Berlin: Springer International Publishing.
- Klein, E. (1995). Second versus third language acquisition: Is there a difference? *Language Learning*, 45(3), 419–465.
- Lambert, W. E. (1981). Bilingualism and language acquisition. In H. Winitz (Ed.), *Native language and foreign language acquisition* (pp. 9–22). New York: The New York Academy of Sciences.
- MacWhinney, B., & Bates, E. (1989). *The crosslinguistic study of sentence processing*. Cambridge: Cambridge University Press.
- McLaughlin, B., & Nayak, N. (1989). Processing a new language: Does knowing other languages make a difference? In H. W. Dechert & M. Raupach (Eds.), *Interlingual processes* (pp. 5–16). Tübingen: Gunter Narr.
- Meara, P. M. (2005). *Llama language aptitude tests: The manual*. Swansea: Lognostics.
- Morgan-Short, K. (2014). Electrophysiological approaches to understanding second language acquisition: A field reaching its potential. *Annual Review of Applied Linguistics*, 34, 15–36.
- Nation, R., & McLaughlin, B. (1986). Novices and experts: An information processing approach to the “good language learner” problem. *Applied Psycholinguistics*, 7(1), 41–55.
- Nayak, N., Hansen, N., Krueger, N., & McLaughlin, B. (1990). Language-learning strategies in monolingual and multilingual adults. *Language Learning*, 40, 221–244.
- Odlin, T. (2012). Nothing will come of nothing. In B. Kortmann & B. Szmrecsanyi (Eds.), *Linguistic complexity in interlanguage varieties, and contact languages* (pp. 53–73). Frankfurt: de Gruyter.
- Pérez Vidal, C. (2014). *Study abroad and language acquisition: Context and contact matters*. Amsterdam: John Benjamins.
- Rothman, J. (2011). L3 syntactic transfer selectivity and typological determinacy: The typological primacy model. *Second Language Research*, 27(1), 107–127.
- Sanz, C. (1997). Issues in SLA research methodology: Production processes and variability. In W. R. Glass & A. T. Pérez-Lerroux (Eds.), *Current approaches to L1 and L2 acquisition of Spanish*. Cambridge: Cascadilla Press.
- Sanz, C. (2000). Bilingual education enhances third language acquisition: Evidence from Catalonia. *Applied Psycholinguistics*, 21, 23–44.
- Sanz, C., Lin, H., Lado, B., Bowden, H. B., & Stafford, C. A. (2009). Concurrent verbalizations, pedagogical conditions, and reactivity: Two CALL studies. *Language Learning*, 59(1), 33–71.
- Sanz, C., Park, H. I., & Lado, B. (2014). A functional approach to cross-linguistic influence in ab initio L3 acquisition. *Bilingualism: Language and Cognition*. doi:10.1017/S1366728914000285.

- Schwartz, B. D., & Sprouse, R. (1996). L2 cognitive states and the full transfer/full access model. *Second Language Research*, 12, 40–72.
- Stafford, C., Sanz, C., & Bowden, W. H. (2010). An experimental study of early L3 development: Age, bilingualism and classroom exposure. *International Journal of Multilingualism*, 7(2), 162–183.
- Swain, M., Lapkin, S., Rowen, N., & Hart, D. (1990). The role of mother tongue literacy in third language learning. *Language, Culture and Curriculum*, 3(1), 65–81.
- Thompson, A. S. (2013). The interface of language aptitude and multilingualism: Reconsidering the bilingual/multilingual dichotomy. *The Modern Language Journal*, 97(3), 685–701.
- Ushioda, E. (2001). Language learning at university: Exploring the role of motivational thinking. In Z. Dornyei & R. Schmidt (Eds.), *Motivation and second language acquisition* (pp. 69–90). Honolulu: University of Hawaii, Second Language Teaching and Curriculum Center.
- Wagner, D., Spratt, J., & Ezzaki, A. (1989). Does learning to read in a second language always put the child at a disadvantage? Some counterevidence from Morocco. *Applied Psycholinguistics*, 10, 31–48.
- Winke, P. (2013). An investigation into second language aptitude for advanced Chinese language learning. *Modern Language Journal*, 97(1), 109–130.



---

# Research Perspectives on Bilingualism and Bilingual Education

Li Wei

---

## Abstract

This chapter outlines key research perspectives on bilingualism and bilingual education. Three broad perspectives are identified: linguistic, psycholinguistic, and sociolinguistic. The chapter focuses on theoretical questions and methodological approaches within each of the three broad perspectives and highlights the differences and links across each. Recent and current work on bilingual education and future directions are discussed.

---

## Keywords

Methods • Bilingual education • Psycholinguistics • Sociolinguistics • Linguistics • Translanguaging

## Contents

Introduction .....	216
Early Developments .....	216
Major Contributions .....	219
Psycholinguistic Approaches to Bilingualism .....	219
Sociolinguistic Approaches to Bilingualism .....	221
Current Work on Bilingual Education .....	223
Challenges and Future Directions .....	224
Cross-References .....	224
Related Articles in the Encyclopedia of Language and Education .....	225
References .....	225

---

Li. Wei (✉)

UCL Institute of Education, University College London, London, UK

e-mail: [li.wei@ucl.ac.uk](mailto:li.wei@ucl.ac.uk)

## Introduction

This chapter outlines various research perspectives on bilingualism and bilingual education. Three broad perspectives within this interdisciplinary area are identified: linguistic, psycholinguistic, and sociolinguistic. The chapter focuses on theoretical questions and methodological approaches within each of the three broad perspectives, highlighting the differences and links across each.

---

## Early Developments

Bilingualism and bilingual education became a major focus of scientific research only in the last century, especially since the 1970s. Two disciplines that have influenced much of the research on bilingualism and bilingual education are linguistics and psychology. The research agenda of much of modern linguistics was defined by Chomsky (1986) as consisting of three basic questions:

1. What constitutes knowledge of language?
2. How is knowledge of language acquired?
3. How is knowledge of language put to use?

For bilingualism research, these questions can be rephrased to take into account knowledge of more than one language:

1. What is the nature of language or grammar in a bilingual person's mind, and how do two systems of language knowledge coexist and interact?
2. How is more than one grammatical system acquired, either simultaneously or sequentially? In what respects does bilingual acquisition differ from monolingual acquisition?
3. How is the knowledge of two or more languages used by the same speaker in bilingual interaction?

Linguists and psychologists working on bilingualism have addressed these questions with a variety of methods and types of data.

Concerning bilingual knowledge, for example, Weinreich (1953) proposed three types of bilinguals (see Fig. 1) representing three types of relationships between the linguistic sign (or signifier) and the semantic content (signified). In Type A, the individual combines a signifier from each language with a separate unit of signified. Weinreich called such individuals "coordinative" (later often called "coordinate") bilinguals. In Type B, the individual identifies two signifiers, but regards them as a single compound, or composite, unit of signified, hence "compound" bilinguals. Type C refers to people who learn a new language with the help of a previously acquired one. They are called "subordinative" (or "subordinate") bilinguals. His examples for each type were from English and Russian.

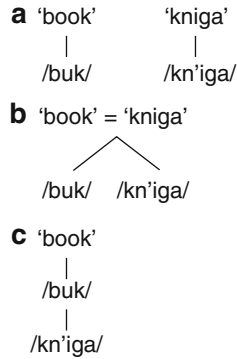

**Fig. 1** Three types of bilinguals

Weinreich’s typology is often misinterpreted in the literature as referring to differences in proficiency in each language. But in fact the relationship between language proficiency and cognitive organization of the bilingual individual is far from clear in Weinreich’s model. Weinreich argued that some “subordinate” bilinguals demonstrated a very high level of proficiency in processing both languages, as evidenced in grammaticality and fluency of speech, while some “coordinative” bilinguals showed difficulties in processing two languages simultaneously (i.e., in code-switching or in “foreign” words identification tasks). Using Weinreich’s distinctions, bilinguals are distributed along a continuum from a subordinate or compound end to a coordinate end and can at the same time be more subordinate or compound for certain concepts and more coordinate for others, depending on, for instance, the age and context of acquisition.

On the acquisition of bilingual knowledge, both linguists and psychologists have intensively studied language development of bilingual children. For instance, in an early study, Volterra and Taeschner (1978) suggested three key stages of lexical and syntactic development among children exposed to two languages:

- Stage I: The child has one lexical system comprising words from both languages.
- Stage II: The child distinguishes two different lexicons, but applies the same syntactic rules to both languages.
- Stage III: The child speaks two languages differentiated both in lexicon and syntax, but each language is associated with the person who uses that language.

Although there is some research support for Volterra and Taeschner’s (1978) model, it has also been heavily critiqued, especially with respect to the first two stages (e.g., De Houwer 2009; Genesee 2002; Meisel 2011). This is generally known as the “one-system-or-two” debate, that is, do bilingual children begin with a fused linguistic system and gradually differentiate the two languages or do they start with a differentiated system? Part of that debate centers around the question: what counts as evidence for differentiation or fusion? Volterra and Taeschner, for instance, based

their decision on whether the child made appropriate sociolinguistic choices, that is, whether the child spoke the “right” language to the “right” person. They argued that awareness of the two languages as distinct plays a crucial role in deciding the issue of differentiation, and a child’s ability to make appropriate language choices reflects that awareness. However, this is a circular argument unless some criterion is provided for assessing what is meant by awareness other than that children separate the languages. A child’s apparent (in)ability to choose the right language for the right addressee is a rather different issue from whether the child has one or two linguistic systems. There now exists a large body of literature rebutting the “fused” system hypothesis, suggesting instead that bilinguals have two distinct but interdependent systems from the very start (e.g., Genesee 2002; Paradis and Genesee 1996).

Research on bilingual language use began with broad descriptions of language choice patterns. Fishman’s (1965) domain analysis, for example, outlined the ways in which speakers make their language choices according to topic, setting, and participant. Gumperz (1982) identified a range of discourse functions of bilingual code-switching, which he defined as alternation of language within an interactional episode. Such functions include, for instance, quotation, addressee specification, interjections, and reiteration. In the meantime, linguists proposed various grammatical constraints on code-switching (e.g., Myers-Scotton 1993; Poplack 1980). Such descriptive accounts laid the foundation for subsequent research on bilingual interaction.

The earliest work on bilingual education in turn was heavily influenced by the widespread view in the field of psychology that bilingualism had a detrimental effect on a human being’s intellectual and spiritual growth. The following is a quote from a professor at Cambridge University, which illustrates the dominant belief of the time, even among academics and intellectuals:

If it were possible for a child to live in two languages at once equally well, so much the worse. His intellectual and spiritual growth would not thereby be doubled, but halved. Unity of mind and character would have great difficulty in asserting itself in such circumstances. (Laurie 1890, p. 15)

Laurie’s quote represents a commonly held belief through the twentieth century that bilingualism disadvantages rather than advantages one’s intellectual development. The early research on bilingualism and cognition tended to confirm this negative viewpoint, finding that monolinguals were superior to bilinguals on intelligence tests. One of the most widely cited studies was done by Saer (1923), who studied 1,400 Welsh-English bilingual children between the ages of 7 and 14 in five rural and two urban areas of Wales. A ten-point difference in IQ was found between the bilinguals and the monolingual English speakers from rural backgrounds. Saer concluded that bilinguals were mentally confused and at an intellectual disadvantage compared with monolinguals. It was further suggested, via a follow-up study of university students, that “the difference in mental ability as revealed by intelligence tests is of a permanent nature since it persists in students throughout their university career” (Saer 1924, p. 53).

A later version of this deficient view of bilingual children manifested in the term “semilingual.” Semilinguals were believed to have linguistic deficits in six areas of language (see Hansegard 1975):

1. Size of vocabulary
2. Correctness of language
3. Unconscious processing of language
4. Language creation
5. Mastery of the functions of language
6. Meanings and imagery

It is significant that the term “semilingualism” emerged in connection with the study of language skills of people belonging to immigrant and ethnic minority groups. Supporting research was conducted in Scandinavia and North America and was concerned with accounting for the educational outcomes of submersion programs, where minority children were taught through the medium of the majority language. However, these studies, like the ones conducted by Saer, had at least four methodological flaws. First, the tests that were used to measure language proficiencies were insensitive to the qualitative aspects of language use. Language is often specific to a context; a person might be competent in some contexts but not in others. Second, as bilingual children are still in the process of developing their languages, it is not valid to compare them to some idealized adults. Third, the comparison with monolinguals is also unfair. It is important to recognize that bilinguals are “naturally” qualitatively and quantitatively different from monolinguals in their use of the two languages, that is, as a function of being bilingual. Fourth, if participants’ languages are relatively underdeveloped, the origins may not be in bilingualism per se, but in the economic, political, and social conditions that evoke underdevelopment. Monolingual and bilinguals in these studies were not comparable in other respects (e.g., socioeconomic status), so results were confounded.

---

## Major Contributions

### Psycholinguistic Approaches to Bilingualism

Many of the questions first raised in these earlier studies were challenged by subsequent research, using better methodologies and technologies. For example, current psycholinguistic models of the bilingual lexicon, such as the concept mediation model and the word association model (e.g., Potter et al. 1984) and the revised hierarchical model (Kroll and Stewart 1994), take into consideration proficiency level, age, and context of acquisition and have much great explanatory power.

Psycholinguists also have used the latest functional neuroimaging technologies to investigate the cognitive organization of languages in the bilingual brain (e.g.,

Abutalebi et al. 2005). The key research question here is the relationship between the neurobiological substrate for multiple languages and environmental influences such as age of acquisition, exposure, and proficiency. While the patterns of brain activation associated with tasks that engage specific aspects of linguistic processing are remarkably consistent across different languages and different speakers, factors such as proficiency seem to have a major modulating effect on brain activity: more extensive cerebral activations associated with production in the less-proficient language and smaller activations with comprehending the less-proficient language.

In terms of acquisition of bilingual knowledge, a more interesting question than the one-or-two-systems debate has emerged. Specifically, is bilingual acquisition the same as monolingual acquisition? Theoretically, separate development is possible without there being any similarity with monolingual acquisition. Most researchers argue that bilingual children's language development is by and large the same as that of monolingual children (Meisel 2011). In general terms, both bilingual and monolingual children go through an initial babbling stage, followed by the one-word stage, the two-word stage, the multiword stage, and the multi-clause stage. At the morphosyntactic level, a number of studies have reported similarities rather than differences between bilingual and monolingual acquisition. Nevertheless, one needs to be careful in the kinds of conclusions one draws from such evidence. Similarities between bilingual and monolingual acquisition do not mean that (1) the two languages a bilingual child is acquiring develop in the same way or at the same speed and (2) the two languages a bilingual child is acquiring do not influence and interact with each other.

There is one area in which bilingual children clearly differ from monolingual children, namely, code-mixing. Studies show that bilingual children mix elements from both languages in the same utterance as soon as they can produce two-word utterances (e.g., De Houwer 2009; Deuchar and Quay 2000; Lanza 1997). As with adult code-switching, bilingual children's language mixing is highly structured. The operation of constraints based on surface features of grammar, such as word order, is evident from the two-word/morpheme stage onward, and the operation of constraints based on abstract notions of grammatical knowledge is most evident in bilingual children once they demonstrate such knowledge overtly (e.g., verb tense and agreement markings), usually around 2.6 years of age and older (Koppe and Meisel 1995). As Genesee (2002) pointed out, these findings suggest that, in addition to the linguistic competence to formulate correct monolingual strings, bilingual children have the added capacity to coordinate their two languages online in accordance with the grammatical constraints of both languages during mixing. While these studies have provided further evidence for the separate development, or two systems, argument, they have also suggested that there are both quantitative and qualitative differences between bilingual acquisition and monolingual acquisition.

Psycholinguistic approaches to bilingualism have offered insights into how multiple languages are simultaneously acquired and represented by the bilingual individuals. The typical methods psycholinguists use tend to be laboratory based, using carefully designed experiments or standard assessments. These methods, together with the theoretical models that psycholinguists have developed, have

enhanced the status of bilingualism research in the scientific community. Nevertheless, the transfer of the scientific knowledge of bilingualism to real-world issues, such as the education of bilingual and multilingual children in schools and communities, remains a challenge.

## **Sociolinguistic Approaches to Bilingualism**

In contrast to linguistic and psycholinguistic researchers, sociolinguists see bilingualism and multilingualism as socially constructed phenomena and the bilingual and multilingual person as a social actor. For the multilingual speaker, language choice is not only an effective means of communication but also an act of identity (Le Page and Tabouret-Keller 1985). Every time we say something in one language instead of another, we are reconnecting with people, situations, and power configurations from our history of past interactions and imprinting on that history our attitudes toward the people and languages concerned. Through language choice, we maintain and change ethnic group boundaries and personal relationships and construct and define “self” and “other” within a broader political economy and historical context. Issues of identity and identification are paramount for the sociolinguist.

In early variationist sociolinguistic work (e.g., Labov 1972), identity was taken to mean the speaker’s social economic class, gender, age, or place of origin. It was assumed that speakers expressed identities through their language use. Scholars such as Rampton (1999) have criticized such assumption, arguing that identities are negotiated locally through social interaction. Further, linguistic forms and strategies have multiple functions and cannot be directly linked to particular identities outside of interactional contexts. More recent work by Pavlenko and Blackledge (2004), using critical discourse analysis, emphasizes the negotiation of identities.

The idea that identity is negotiable can be traced back to the work of social psychologists who were interested in group processes and intergroup relations (e.g., Tajfel 1981). Identity, from this particular perspective, is reflective self-image, constructed, experienced, and communicated by the individual within a group. Negotiation is seen as a transactional process, in which individuals attempt to evoke, assert, define, modify, challenge, and/or support their own and others’ desired self-images. Identity domains such as ethnic, gender, relational, face work are seen as crucial for everyday interaction. Speakers feel a sense of identity security in a culturally familiar environment, but insecurity in a culturally unfamiliar environment. Satisfactory identity negotiation outcomes would include the feelings of being understood, valued, supported, and respected.

There are two major problems with such an approach. First, the categories used in the analysis are often rigid and ill-defined and have a monolingual and unicultural bias. The world is often seen as consisting of “them” and “us,” “in-group” and “out-group,” or “we code” and “they code.” The so-called negotiation, in this particular perspective, is unidirectional – the native speaker abandoning (or at least modifying) his or her first language and culture in order to learn the language of the host culture. This process is often known as “convergence” or “acculturation” (Gudykunst and

Kim 2003). The second major problem concerns the approach's static and homogeneous view of culture and society. It does not take into account the historical, ideological, economic processes that led to the present social grouping or stratification (Zhu 2013).

Adopting a post-structuralist approach to the notion of identity, Pavlenko and Blackledge (2004) argued that the relationship between language and identity is mutually constitutive and that identities are multiple, dynamic, and subject to change. For them, negotiation of identities is the interplay between reflective positioning, that is, self-representation and interactive positioning, whereby others attempt to reposition particular individuals or groups. Their analyses of multilingualism and identities in a variety of social contexts demonstrate that languages are appropriated to legitimize, challenge, and negotiate particular identities and to open new identity options. Identity options as constructed, validated, and performed through discourses available to individuals at particular times and places, that is, certain linguistic resources may be available to certain groups of speakers, while others may not.

Parallel to the work on multilingualism and negotiation of identities, sociolinguists critically examine some of the concepts and notions commonly used by other researchers in the field of bilingualism and multilingualism. For example, the very idea of code-switching raises questions as to what a language is. Instead of thinking of languages as discrete systems, sociolinguists tend to see multilingual speakers as actors of social life who draw on complex sets of communicative resources which are unevenly distributed and unevenly valued (Heller 2003). The linguistic systematicity therefore appears to be at least as much a function of historically rooted ideologies (of nation and ethnicity) and of the ordering practices of social life as of language per se. This perspective goes beyond a focus on mental representation of linguistic knowledge and opens up the possibility of looking at bilingualism and multilingualism as a matter of ideology, communicative practice, and social process.

This particular sociolinguistic perspective has important implications for the way researchers collect, analyze, and interpret data. Informed by developments in anthropology, sociology, and cultural studies, sociolinguists have examined communicative practices within and across sites that can be ethnographically demonstrated to be linked. Working with the ideas of *trajectories* (of speakers, linguistic resources, discourses, institutions) across time and space and of *discursive spaces* which allow for, and also constrain, the production and circulation of discourses, Heller (2003) has examined multilingual practices in a number of communities and argued that multilingual practices contribute to the construction of social boundaries and of the resources those boundaries regulate. They therefore also raise the question of the social and historical conditions which allow for the development of particular regimes of language and for their reproduction, their contestation, and eventually, their modification or transformation.

A further, closely related area in which sociolinguists have extended the work by linguists and psycholinguists on bilingualism is that of the acquisition of linguistic knowledge. Building on earlier research on language socialization, which focused on



young children acquiring their first language in culturally specific ways, scholars such as Bayley and Schecter (2003) examined bilingual and multilingual children's developing competence in various speech and literacy events. Particular attention is given to the range of linguistic resources available, or not, in bilingual and multilingual communities and the ways in which children, as well as adolescents and adults, learn to choose among these resources for their symbolic value. The researchers emphasized language socialization as an interactive process, in which those being socialized also act as agents rather than as mere passive initiates. This line of inquiry also demonstrates how domains of knowledge are constructed through language and cultural practices and how the individual's positioning affects the process of knowledge acquisition and construction.

---

## Current Work on Bilingual Education

While traditional research questions (e.g., cognitive advantages and disadvantages of bilingualism for children, bilingual assessment, bilingual classroom interaction, and language-in-education policy) continue to influence research on bilingual education, an important strand in the current bilingual education research examines how new minority communities respond to the lack of status accorded to them and their languages. Mainstream education in many contexts neglects the real-life social experiences of cultural and linguistic diversity (e.g., Hornberger and King 1996). As a result, new minority communities often set up schools themselves in order to promote their cultures and languages. Indeed, in the UK, the government has put the issue of language and cultural maintenance in the hands of the new minorities themselves, and such educational provision has been set up in addition to the education provided by the state (Blackledge and Creese 2010).

This form of community language education has provided a "safe" but largely hidden space in which specific communities can learn about their own cultures and languages. Although there has been a large amount of work in Britain, North America, and Australia which points to crucial connections between minority communities and their languages, cultures, religions, literacy practices, and identities, there is a dearth of studies which focus specifically on community language education initiatives. Much of the work that is available demonstrates how ethnic minority children benefit from their multilingualism and the bilingual opportunities that the schools provide. For example, Hall et al. (2002) noted how attendance at supplementary schools provides "a way of reclaiming the specificity of cultural and social identity . . . missing from mainstream schooling" (p. 409). In their comparative study of provision, purposes, and pedagogy of supplementary schooling in Leeds (UK) and Oslo (Norway), Hall et al. found that supplementary education "imbues its participants with a sense of belonging to a community that supports them practically, culturally, socially, emotionally and spiritually" (p. 410). These important issues can be linked back to the social experiences of using languages, rather than simply the celebration of linguistic diversity. Such educational opportunities provide a safe haven for young people from the new minorities to use their

bilingualism in creative and flexible ways (cf. García and Li 2014). Nevertheless, relatively little is still known about the educational pedagogies of such schooling as well as the relationship between mainstream and supplementary education.

---

## Challenges and Future Directions

The highly politicized nature of bilingual education, especially the education of children from immigrant and minority ethnic backgrounds, poses an important challenge to both policy and research in this area. Important questions need to be addressed, such as: Why are there different viewpoints about linguistic minorities and bilingual education? Why do some people prefer the assimilation of linguistic minorities and others prefer linguistic diversity? What role can schools play in a more multicultural and less racist society? Ideally, a bilingual educational program should aim to produce bilingual products in the form of bilingual speakers, though in practice it is often the case only one language is taught or used in the actual classroom. Many of the so-called bilingual education programs in the UK and Europe, for example, are in fact English or other European language programs for children whose first languages are different. In the meantime, the heritage/community language schools often insist on teaching or using their heritage/community language only. The official discourse does not encourage students and teachers to practice bilingualism in the heritage/community education context.

Yet the most important feature of a bilingual being is bilingual practice, and the form of practice that is most distinctly bilingual is code-switching. In the last four decades, code-switching has attracted a considerable amount of interest in various branches of linguistics, including sociolinguistics and psycholinguistics. The vast majority of this work, however, focuses on noninstitutional contexts. There is an urgent need to extend our knowledge of code-switching in specific institutional contexts, for example, the classroom. Real tensions are often found in such educational contexts. Whereas code-switching in the community is regarded as acceptable bilingual talk, the same cannot be said to be the case for many classroom contexts (Canagarajah 2011; Lin and Martin 2005). Indeed, the literature on classroom code-switching is littered with metaphors which underpin such conflict. Examples are the notions of “collusion,” “safe talk,” “sabotage,” and “incomplete journeys” (reviewed in García and Li 2014). Further research on the use, conflict, and tensions of code-switching in the classroom will not only help to focus on what really matters to bilingual individuals in real life but also extend and link the fields of education, linguistics, psycholinguistics, and sociolinguistics (García and Li 2014).

---

## Cross-References

- ▶ [Code-Switching in the Classroom: Research Paradigms and Approaches](#)
- ▶ [From Researching Translanguaging to Translanguaging Research](#)

## Related Articles in the Encyclopedia of Language and Education

- Lynn Fogle and Kendall King: [Bi- and Multilingual Family Language Socialization](#).  
In Volume: Language Socialization
- Ofelia García and Angel M.Y. Lin: [Translanguaging in Bilingual Education](#).  
In Volume: Bilingual Education
- Stephen May: [Bilingual Education: What the Research Tells Us](#). In Volume:  
Bilingual Education

---

## References

- Abutalebi, J., Cappa, S. F., & Perani, D. (2005). What can functional neuroimaging tell us about the bilingual brain? In J. Kroll & A. M. B. de Groot (Eds.), *Handbook of bilingualism* (pp. 497–515). Oxford: Oxford University Press.
- Bayley, R., & Schecter, S. R. (2003). *Language socialization in bilingual and multilingual societies*. Clevedon: Multilingual Matters.
- Blackledge, A., & Creese, A. (2010). *Multilingualism: A critical perspective*. London: Bloomsbury.
- Canagarajah, S. (2011). Translanguaging in the classroom: Emerging issues for research and pedagogy. *Applied Linguistics Review*, 2(1), 128.
- Chomsky, N. (1986). *Knowledge of language: Its nature, origin and use*. New York: Praeger.
- De Houwer, A. (2009). *Bilingual first language acquisition*. Bristol: Multilingual Matters.
- Deuchar, M., & Quay, S. (2000). *Bilingual acquisition*. Oxford: Oxford University Press.
- Fishman, J. (1965). Who speaks what language to whom and when? *La Linguistique*, 2, 67–88.
- García, O., & Li, W. (2014). *Translanguaging: Language, bilingualism and education*. London: Palgrave.
- Genesee, F. (2002). Rethinking bilingual acquisition. In J.-M. Dewaele, A. Housen, & L. Wei (Eds.), *Bilingualism: Beyond basic principles* (pp. 204–228). Clevedon: Multilingual Matters.
- Gudykunst, W. B., & Kim, Y. Y. (2003). *Communicating with strangers: An approach to intercultural communication* (4th ed.). New York: McGrawHill Education.
- Gumperz, J. J. (1982). *Discourse strategies*. Cambridge: Cambridge University Press.
- Hall, K., Kamil, Ö., Mohsin, Z., & Jon, T. (2002). “This is our school”: Provision, purpose and pedagogy of supplementary schooling Leeds and Oslo. *British Educational Research Journal*, 28(2), 399–418.
- Hansegard, N. E. (1975). Tvasprakighet eller havsprakighet? *Invandrare och Minoriteter*, 3, 713.
- Heller, M. (2003). Globalization, the new economy, and the commodification of language and identity. *Journal of Sociolinguistics*, 7(4), 473–492.
- Hornberger, N. H., & King, K. A. (1996). Language revitalisation in the Andes: Can the schools reverse language shift? *Journal of Multilingual and Multicultural Development*, 17(6), 427–441.
- Koppe, R., & Meisel, J. (1995). Code switching in bilingual first language acquisition. In L. Milroy & P. Muysken (Eds.), *One speaker two languages* (pp. 276–301). Cambridge: Cambridge University Press.
- Kroll, J., & Stewart, E. (1994). Category interference in translation and picture naming: Evidence for asymmetric connections between bilingual memory representations. *Journal of Memory and Language*, 33, 149–174.
- Labov, W. (1972). *Sociolinguistic patterns*. Philadelphia: University of Pennsylvania Press.
- Lanza, E. (1997). *Language mixing in infant bilingualism*. Oxford: Oxford University Press.
- Laurie, S. S. (1890). *Lectures on language and linguistic method in school*. Cambridge: Cambridge University Press.

- Le Page, R., & Tabouret-Keller, A. (1985). *Acts of identity: Creole-based approaches to language and ethnicity*. Cambridge: Cambridge University Press.
- Lin, A. M. Y., & Martin, P. W. (Eds.). (2005). *Decolonisation, globalisation: Language-in-education policy and practice*. Clevedon: Multilingual Matters.
- Meisel, J. M. (2011). *First and second language acquisition: Parallels and differences*. Cambridge: Cambridge University Press.
- Myers-Scotton, C. (1993). Social motivations for code-switching: evidence from Africa. Oxford: Clarendon Press.
- Paradis, J., & Genesee, F. (1996). Syntactic acquisition in bilingual children. *Studies in Second Language Acquisition*, 18, 125.
- Pavlenko, A., & Blackledge, A. (Eds.). (2004). *Negotiation of identities in multilingual settings*. Clevedon: Multilingual Matters.
- Poplack, S. (1980). Sometimes i'll start a sentence in Spanish y termino en espanol. *Linguistics*, 18, 581–618.
- Potter, M. C., So, K.-F., Von Echardt, B., & Feldman, L. B. (1984). Lexical and conceptual representation in beginning and more proficient bilinguals. *Journal of Verbal Learning and Verbal Behaviour*, 23, 23–38.
- Rampton, B. (1999). Styling the other. [Thematic issue]. *Journal of Sociolinguistics*, 3(4), 421–590.
- Saer, D. J. (1923). An inquiry into the effect of bilingualism upon the intelligence of young children, Part I. *Journal of Experimental Psychology*, 6, 232–240; Part II, 6, 266–274.
- Saer, D. J. (1924). The effect of bilingualism on intelligence. *British Journal of Psychology*, 14, 25–38.
- Tajfel, H. (1981). *Human groups and social categories*. Cambridge: Cambridge University Press.
- Volterra, V., & Taeschner, T. (1978). The acquisition and development of language by bilingual children. *Journal of Child Language*, 5, 311–326.
- Weinreich, U. (1953). *Languages in contact: Findings and problems*. New York: The Linguistic Circle of New York.
- Zhu, H. (2013). *Exploring intercultural communication: Language in action*. London: Routledge.

---

# From Researching Translanguaging to Translanguaging Research

Li Wei and Ofelia García

---

## Abstract

Translanguaging research has recently increased in visibility. But research in what we now term translanguaging is not new. This chapter traces its development from its Welsh origins to worldwide translanguaging research today. It grounds this development in the increased questioning of monolingual practices, especially in education, that were the hallmark of twentieth century society. This chapter also makes visible the challenges that translanguaging research poses, as the language practices of multilinguals continue to be constrained by institutions in nation-states.

---

## Keywords

Translanguaging • Dynamic bilingualism • Bilingual education • Multilingualism • Culture • Language

## Contents

Introduction .....	228
Early Developments .....	228
Major Contributions .....	231
Work in Progress .....	234
Problems and Difficulties .....	236
Future Directions .....	237
Conclusion .....	237
Cross-References .....	238

---

Li Wei (✉)

UCL Institute of Education, University College London, London, UK

e-mail: [li.wei@ucl.ac.uk](mailto:li.wei@ucl.ac.uk)

O. García

Urban Education, Hispanic and Luso-Brazilian Literatures and Languages, City University of New York, New York, NY, USA

e-mail: [OGarcia@gc.cuny.edu](mailto:OGarcia@gc.cuny.edu)

Related Articles in the Encyclopedia of Language and Education .....	238
References .....	238

---

## Introduction

Researching translanguaging, that is, studying the language practices of bilinguals from their own dynamic perspective, rather from the static monoglossic one of monolinguals, and examining the ways in which those resources are deployed in teaching and learning, characterizes much multilingual research in the twenty-first century. In this chapter, we review how the concept of translanguaging emerged, as well as how it is being used today to research this “multilingual turn” (Conteh and Meier 2014; May 2013).

Translanguaging suggests that because bilingualism is dynamic (García 2009), researchers cannot assume that there are clear-cut boundaries between the languages of speakers whose language repertoire includes features that are associated with two or more national languages. Researchers who work with translanguaging distinguish between national languages as social constructions of nation-states and the language practices of bilinguals. In so doing, translanguaging research reminds us that although different languages do not have objective linguistic reality, they do have a social reality that impacts bilingual speakers. This is so especially when it comes to educational systems that function only in one language at a time, even in much bilingual education. Translanguaging research in education focuses then on whether flexible instructional arrangements that leverage all the features of the language repertoire of bilingual students can improve their academic engagement and outcomes, as well as develops their bilingualism and biliteracy. It also focuses on whether translanguaging can develop the metacognitive and metalinguistic awareness of bilingual students so that they can use appropriate features of their repertoire in different communicative circumstances. From the beginning, this has been the focus of much translanguaging research.

---

## Early Developments

The term *translanguaging* comes from the Welsh *trawsieithu*. It was coined by Williams (1994) and popularized through Baker’s textbook *Foundations of Bilingual Education and Bilingualism* (2001 and subsequent editions). In its original use, it referred to a pedagogical practice where students are asked to alternate languages for the purposes of receptive or productive use; for example, students might be asked to read in English and write in Welsh and vice versa. Lewis et al. (2012a, b) described the historical context in which translanguaging practices emerged. The Welsh language revitalization efforts began to show signs of success in the final decades of the twentieth century. Lewis et al. (2012a) explained:

By the 1980s, the idea of Welsh and English as holistic, additive, and advantageous was beginning, allowing the idea of translanguaging to emerge – firstly, within education in North Wales and, subsequently, developing within that educational context especially at classroom level. (p. 624)

Williams (2012) emphasized the capacity of translanguaging in the Welsh classroom to reinforce understanding of what is being taught and to augment the pupil's activity in both languages. The cognitive processing involved in translanguaging was seen to be particularly useful for retaining and developing bilingualism. As Baker (2011) explained, “to read and discuss a topic in one language, and then to write about it in another language, means that the subject matter has to be processed and ‘digested’” (p. 289). Translanguaging as a pedagogical practice not only promotes a deeper understanding of content, but also develops the weaker language in relationship with the one that is more dominant. In addition, translanguaging promotes the integration of those who are emergent bilinguals with those who have fuller use of bilingualism in a classroom. Lewis et al. (2013) reported on a 5-year longitudinal research project in Wales, using a combination of observation and standardized measures, that showed widespread use of translanguaging in schools in Wales, as well as its academic advantages to develop students' bilingualism.

As we can see, the notion of translanguaging was tied with language policy, especially language-in-education policy, from the very start. Translanguaging was seen as a challenge to the one-language-at-a-time policies that were dominant in society and scholarship at the time. Despite the dominance of monolingual instructional pedagogy in the teaching of additional languages – whether in foreign language, bilingual, heritage, or second language classrooms – researchers started to question its validity at the end of the twentieth century, coinciding with globalization, technological changes, and increased movement of people throughout the world. The early development of the present concept of translanguaging also owed much to the work of other researchers in different contexts who did not use the term translanguaging, but challenged the monolingual assumptions in language education, researching what Cummins (2007) has called “bilingual instructional strategies.”

As early as 1979, Cummins introduced his Interdependence Hypothesis, which posited that much crosslinguistic transfer occurs because languages are connected by means of a common underlying proficiency. There was substantial early research to support Cummins' Interdependence Hypothesis, including much in the teaching of US Latinos, for example, that of Moll and Díaz (1985) that showed that Latino students who were learning English increased their reading proficiency in English if they were allowed to discuss in Spanish. In the 1990s, in the United States, Jacobson proposed the “concurrent approach” in bilingual education of language-minoritized students, which required teachers to change languages, although only inter-sententially. Research into this approach was inconclusive and partial, but it opened the door to questioning the assumption of what Cummins (2008) has called the “two solitudes” in language education.

Around the same time, many researchers started to document the positive effect of what they labeled “code-switching” in the education of language-minoritized students in postcolonial contexts (see, e.g., Lin 1999; Lin and Martin 2005; Martin 2005). Lin’s (1996) study of Cantonese-English code-switching in Hong Kong showed that it served important sociocultural, linguistic, and educational functions. Lemke (2002) questioned “could it be that all our current pedagogical methods in fact make multilingual development more difficult than it need be, simply because we bow to dominant political and ideological pressures to keep ‘languages’ pure and separate?” (p. 85).

Studying dual-language bilingual education programs in the United States during the first decade of the twenty-first century Fitts (2006) demonstrated how language separation had detrimental effects on students because it “illegitimizes the use of vernaculars” (p. 339). Lee et al. (2008) explained that “the strict separation of the two languages for instructional purposes appears to be diminishing opportunities to use both codes as resources to problem-solve or as an indexical strategy” (p. 90). Especially in literacy education, researchers in the United States documented how bilingual writers, young and old, use their home language during writing activities in English to cognitively manage tasks, as well as to leverage their multilingualism (Fu 2003; Gort 2006). In her study of literacy, Martin-Beltrán (2010) noted that bilingual students’ languages “can go back and forth symbiotically as mediational tools and objects of analysis within the same interaction” (p. 256).

In Canada, the strict immersion approach also started to be questioned. Swain and Lapkin (2000) found that the use of the students’ home language moved the task along, allowed learners to focus attention on vocabulary and grammatical items, and enhanced interpersonal interaction. In foreign language education, Anton and DiCamilla’s research (1998) showed that using students’ home languages facilitated the acquisition of an additional language.

All these studies demonstrated the potential of bilingual instructional strategies to teach. But most of these scholars still worked with the concepts of first language (L1), second language (L2), and code-switching, whereas the Welsh concept of translanguaging went beyond these monoglossic ideologies with regard to bilingualism. The Welsh concept of translanguaging was grounded on the linguistic repertoire of Welsh bilingual speakers.

At the same time, the concept of separate languages in additive bilingualism had also started to be seriously questioned. Grosjean, for example, had emphasized that the bilingual is not two monolinguals in one (1989). Cook (1992) elaborated his concept of multi-competence, positing that it is impossible to compare the linguistic competence of a bilingual in each language to that of monolinguals. Dynamic systems theory, as developed by Herdina and Jessner (2002) and de Bot et al. (2007), then argued that the psycholinguistic system of bilinguals is simply different from that of monolinguals.

It is this different way of conceptualizing bilingualism, of viewing bilingualism as dynamic, of language practices in interrelationship, and of a new and transformed linguistic system rather than the addition of two, which has led to the uptake of the term *translanguaging* in scholarship and research in the present.



## Major Contributions

The term translanguaging was taken up by researchers worldwide a decade after it was first used in Wales. The concept was extended to adjust to different sociolinguistic contexts and the various language needs of bilingual people and students. The extension of the concept of translanguaging also owes much to our changing views of multilingualism and the ways in which bilingual people language, now made visible by globalization, increased immigration, and advanced technology.

Studying bilingual education across global contexts, García (2009) broadened the scope of translanguaging to mean “*multiple discursive practices* in which bilinguals engage in order to *make sense of their bilingual worlds*” (p. 45, emphasis in original), as well as the instructional practices that leveraged those practices. For García (2009), translanguaging refers to *new* language practices that make visible the complexity of language exchanges among people with different histories and releases histories and understandings that had been buried within fixed language identities constrained by nation-states. For Creese and Blackledge (2010), translanguaging enables the inspection of bilingual discourse for trace of the social, historical, and political forces that have shaped it. In education, translanguaging has been defined as a “a process by which students and teachers engage in complex discursive practices that include all the language practices of students in a class in order to develop new language practices and sustain old ones, communicate and appropriate knowledge, and give voice to new sociopolitical realities by interrogating linguistic inequality” (García and Kano, as cited in Conteh and Meier 2014, p. 261).

Based on extensive ethnographic research in the Bengali, Chinese, Gujarati, and Turkish complementary schools in Britain, Creese and Blackledge (2010) used the term translanguaging to describe a range of flexible bilingual approaches to language teaching and learning. Creese, Blackledge, and their colleagues argued for a release from monolingual instructional approaches and advocated teaching bilingual children by means of bilingual instructional strategies, in which two or more languages are used alongside each other. In examining the translanguaging pedagogies used in complementary schools, Creese and Blackledge (2010) stated:

Both languages are needed simultaneously to convey the information, . . . each language is used to convey a different informational message, but it is in the bilingualism of the text that the full message is conveyed. (p. 108)

And in analyzing the pair work students do, they commented “it is the combination of both languages that keeps the task moving forward” (p. 110). In developing their argument, Creese and Blackledge took a language ecology perspective and sought to emphasize the interdependence of skills and knowledge across languages.

Canagarajah (2011) described the translanguaging strategies of a Saudi Arabian undergraduate student in her essay writing and how the feedback of the instructor and peers helped her to question her choices of strategies, think critically about diverse options, assess the effectiveness of the choices, and develop metacognitive

awareness. Canagarajah argued that it is possible to learn from students' translanguaging strategies while developing their proficiency through a dialogical pedagogy.

Situating their study in the US national policy context where standardized tests dominate curriculum and instruction and first language literacy is discouraged and undervalued, Hornberger and Link (2012) identified new spaces for innovative programs, curricula, and practices that recognize, value, and build on the multiple, mobile communicative repertoires, and translanguaging/transnational literacy practices of students and their families. They connected translanguaging to Hornberger's (e.g., Hornberger and Link 2012) notion of "continua of biliteracy," enabling the potential "to explicitly valorize all points along the continua of biliterate context, media, content, and development" (p. 268).

Coming from a different perspective and building on the psycholinguistic notion of languaging, a process whereby "language serves as a vehicle through which thinking is articulated and transformed into an artifactual form" (Swain 2006, p. 97), Li Wei (2011) defines translanguaging as going between and beyond different linguistic structures and systems including different modalities. It includes the full range of linguistic performances of multilingual language users for purposes that transcend the combination of structures, the alternation between systems, the transmission of information, and the representation of values, identities, and relationships. The act of translanguaging then is transformative in nature; it creates a social space for multilingual language user by bringing together different dimensions of their personal history, experience, and environment; their attitude, belief, and ideology; their cognitive and physical capacity into one coordinated and meaningful performance and making it into a lived experience. Li Wei calls this space – translanguaging space – a space for the act of translanguaging as well as a space created through translanguaging.

The notion of a translanguaging space is particularly relevant to multilinguals not only because of their capacity to use multiple linguistic resources to form and transform their own lives, but also because the space they create through their multilingual practices, or translanguaging, has its own transformative power. It is a space where the process of what Bhabha (1994) calls "cultural translation" between traditions takes place; it is not a space where different identities, values, and practices simply coexist, but combine together to generate new identities, values, and practices. The boundaries of a translanguaging space are ever shifting; they exist primarily in the mind of the individual who creates and occupies it, and the construction of the space is an ongoing, lifelong process. The idea of translanguaging space, as García and Li Wei (2014) point out, embraces two concepts, namely, creativity and criticality, which are fundamental to multilingual practices. Creativity refers to the ability to choose between following and flouting the rules and norms of behavior, including the use of language. It is about pushing and breaking the boundaries between the old and the new, the conventional and the original, and the acceptable and the challenging. Criticality is the ability to use available evidence appropriately, systematically, and insightfully to inform considered views of cultural, social, and linguistic phenomena; to question and

problematize received wisdom; and to express views adequately through reasoned responses to situations. These two concepts are intrinsically linked. Li Wei (2011) argues that one cannot push or break boundaries without being critical; and the best expression of one's criticality is one's creativity. Multilingualism by the very nature of the phenomenon is a rich source of creativity and criticality, as it entails tension, conflict, competition, difference, and change in a number of spheres, ranging from ideologies, policies, and practices to historical and current contexts. While rapid globalization has made everyday life in late modernity look increasingly routinized, repetitive, and monotonous, the enhanced contacts between people of diverse backgrounds and traditions provide new opportunities for innovation, entrepreneurship, and creativity. Individuals are capable of responding to the historical and present conditions critically. They consciously construct and constantly modify their socio-cultural identities and values through social practices such as translanguaging.

For García and Li Wei (2014), translanguaging is not some new linguistic phenomenon to be investigated in the traditional way. Rather, it offers a brand new analytical lens that would alter our common understandings of language, bilingualism, and education. The emphasis on the "trans" aspects of language and education, as García and Li Wei (2014) claim, enables us to transgress the categorical distinctions of the past. In particular, a "trans" approach to language and education liberates our traditional understandings and points to three innovative aspects in considering language on the one hand and education on the other:

1. Referring to a *trans-system and trans-spaces*; that is, to fluid practices that go *between* and *beyond* socially constructed language and educational systems, structures, and practices to engage diverse students' multiple meaning-making systems and subjectivities.
2. Referring to its *transformative nature*; that is, as new configurations of language practices and education are generated, old understandings and structures are released, thus transforming not only subjectivities, but also cognitive and social structures. In so doing, orders of discourses shift, and the voices of others come to the forefront, relating then translanguaging to criticality, critical pedagogy, social justice, and the linguistic human rights agenda.
3. Referring to the *transdisciplinary* consequences of the languaging *and* education analysis, providing a tool for understanding not only language practices on the one hand and education on the other, but also human sociality, human cognition and learning, social relations, and social structures.

Translanguaging in education also pays attention to the ways in which students combine different modes and media across social contexts and negotiate social identities. For example, Kenner (2004) reported on how bilingual/biliterate young children in the United Kingdom learn different writing systems (Chinese, Arabic, and Spanish) at home, in complementary schools, and in the mainstream primary school. Her work illustrated how a focus on different modes, including the children's sets of linguistic resources, can foreground the different culture-specific ways multilingual children mesh the visual and actional modes (i.e., make use of shape,

size, and location of symbols on the page, directionality, and type of stroke) in the process of learning how to write in two languages. Moreover, such a focus shows the different ways multilingual children combine and juxtapose scripts as well as explore connections and differences between their available writing systems in their text making. By translanguaging, that is, drawing on more than one set of linguistic and other modal resources to construct bilingual texts in settings where multilingual communication was encouraged, Kenner argued, children could “express their sense of living in multiple social and cultural worlds” (p. 118).

Research on translanguaging in schools not only creates the possibility that bilingual students could use their full linguistic and semiotic repertoire to make meaning, but also that teachers would “take it up” as a legitimate pedagogical practice. Rather than just being a scaffolding practice to access content or language, translanguaging is transformative for the child, for the teacher, and for education itself, and particularly for language education. These have been the findings of some of the studies carried out by García and her colleagues (see, for example, Flores and García 2013; García et al. 2012). Velasco and García (2014) showed how translanguaging strategies promote a high sense of self-efficacy, as bilingual students also self-regulate their learning and their use of certain features from their repertoire in different contexts. Thus, translanguaging has come to mean a practice where two or more languages are used in a dynamic and functionally integrated manner to organize and mediate mental processes in understanding, speaking, literacy, and, not least, learning.

Lately, the concept of translanguaging itself has been taken up by many researchers. Especially in studies of pedagogy, researchers are increasingly using the translanguaging lens to study what is going on in multilingual classrooms (see, for example, Sayer 2013). The next section discusses the ways in which researchers are presently extending the concept of translanguaging.

---

## Work in Progress

From its Welsh beginnings as purely an instructional practice in the context of education, the concept of translanguaging is being used today to study the fluidities of language and identity in many different contexts. A new journal appeared in 2015, *Translation and Translanguaging in Multilingual Contexts*, focusing not only on educational contexts, but also in the workplace and on travel. The Translation and Translanguaging research team involving researchers from Birmingham, Birkbeck, Cardiff, Leeds, and UCL in the United Kingdom is also investigating how multilingual speakers translanguage to communicate in business, sports, heritage, and socio-legal domains. The term translanguaging has also been taken up by scholars who study language socialization of bilingual children and especially those who study the use of language by bilingual children who serve as translators in what is called

“language brokering.” *TESOL Quarterly* published an issue in 2013 on plurilingualism in the teaching of English to speakers of other languages. Many of the contributions in that issue make reference to translanguaging.

Translanguaging in assessing what bilinguals know is another area where work is progressing. Shohamy (2011) has long spoken about the need for multilingual assessments. López et al. (forthcoming) have developed a Math test for Spanish-speaking emergent bilinguals in US middle schools (six to eighth grade) that is delivered through a computer-based platform (CBT) and is based on translanguaging. The assessment encourages students to use their language repertoire fully to show what they know. For example, students have the opportunity to see or hear an item in both English and Spanish and to then write or say responses using their full language repertoire. To create the space for translanguaging and encourage student-to-student interactions, students are asked to select a virtual friend or assistant, while responding to content-related questions. This virtual friend can then, for example, provide a read aloud of the assessment item in the language preferred by the student, ensuring that the student can understand the content-related task. The translanguaged multimodal assessment creates a space for translanguaging by stimulating student-to-student interactions and promoting what López and his colleagues call “bilingual autonomy.”

If translanguaging, as García and Li Wei (2014) argue, goes beyond our traditional concept of autonomous languages, focusing on the language features of a bilingual single repertoire which are always available and which bilinguals learn to selectively suppress or activate depending on the communicative context, then the concept of translanguaging can also extend to those who are considered speakers of minoritized varieties of what is considered one national language. In the United States, Barrett (2012) has used translanguaging as the lens to study participation of both Latino and African-American students in a classroom Hip-Hop media production.

Another area of potential is research on the neural bases of translanguaging. Research on cognition and multilingual functioning has supported the view that the languages of bilingual speakers interact collaboratively in listening or speaking (de Groot 2011). Beres (2014) is presently testing the effects of bilingual speakers responding to new knowledge when the response is in the same language as the input as opposed to when it is in a different language than that of instruction, following the Welsh definition of translanguaging. Preliminary findings indicate that when the input and output language are different, rather than the same, students engage in deeper thinking and more meaningful learning.

In New York, García and her colleagues have been deeply involved in development and research of translanguaging in teaching emergent bilingual students. The project, known as CUNY-NYSIEB, has paid attention to what Canagarajah (2011) believes is the area of greater underdevelopment – the pedagogical side. The project has developed a series of materials all accessible under the Publication tab on the project’s website ([www.cuny-nysieb.org](http://www.cuny-nysieb.org)).

## Problems and Difficulties

School systems throughout the world have misled students as they have transmitted only national and selective values about the concept of “language.” Elite students come to believe that the ways in which they use language, which most often reflects the characteristics of the language of school, are the only valid “language.” Minoritized students are also taught that the language practices they bring from home are “corrupted” and inferior to those practiced in schools. In such situations, the definition of language has little to do with the language practices of individuals and everything to do with the will of the dominant groups of the nation-state to conserve their privilege by sanctioning only their language practices that we learn as children in schools. The concept of language that we have acquired has everything to do with its constructed and manipulated social reality and little to do with the complex linguistic reality of speakers, especially multilingual speakers. The language features of individual speakers which they use as they speak, read, and write have little to do with the definition of language as given by the nation-states and their education systems.

Precisely because the complex meanings of “language” have been preempted by the sole national definition, we find it difficult to use the word “language” except when speaking about the constructed concepts of English, Spanish, French, and so on. Translanguaging offers a way of speaking about these individual complex practices of multilingual speakers, although in recognizing multilingualism, it is resorting to the national definitions of language. Thus, the term translanguaging in itself contains a contradiction. On the one hand, it recognizes bilingualism/multilingualism, as languages constructed by nation-states, and validates the material and symbolic reality of this social construction to which bilingual speakers are subjected. But on the other hand, it goes beyond the idea of national languages as linguistic objects and recognizes the bilingual speakers’ features of an integrated repertoire that they use to language.

Because it signals a different linguistic reality, translanguaging is not an easy concept to take up either by speakers themselves, students, or educators. Many resist and argue that only the “language” as defined in national school curricula and grammar books is important and needs to be used in schools. Just as the concept of translanguaging itself contains the contradiction of language as defined by nation-states and language as defined by speakers themselves, translanguaging has to be used not only to legitimize and leverage the fluid language practices of bilinguals to be equal participants in a just society, but also to make bilingual speakers conscious of when and how to use the different features of their repertoire. Research is beginning to emerge that shows that focusing on how to do language, regardless of features, is a much better way of acquiring the “standard” features of language that schools require, than drilling students only on those features. This is, for example, the point made by García et al. (2012) when they focus on developing students’ general linguistic proficiency (i.e., the ability to use language to express complex thoughts, summarize, infer, find evidence, joke, etc.) regardless of specific language features.

Yet another tension in translanguaging research has to do with those who believe that accepting the fluid language practices of bilinguals will in some way weaken the non-dominant language. For example, although English as a second language teachers are often easily convinced of the value of translanguaging in their English-only classrooms, dual-language bilingual teachers in the United States have been more reticent to take it up. This in part has to do with their teacher training, which has in the past focused on complete language separation. But it also has to do with the fear that they will lose the little that they have accomplished in carving out a protected space for the minoritized language.

---

## Future Directions

Some important future directions for research on translanguaging have been suggested throughout this chapter, and especially on the section on Work in Progress. With regard to pedagogy, much research needs to be conducted on what different translanguaging strategies work best with certain students at different times, for various contents. Because pedagogy includes assessment, research on the use of translanguaging in assessment is very much needed.

To date, much translanguaging research has been conducted on the language education of minoritized students, whether in bilingual or second language programs. There is now a need to also conduct research on translanguaging in other educational contexts with dominant language students. There has been much interest in the use of a first language in foreign language instruction, but the field has not embraced translanguaging wholeheartedly. The emergence of Content and Language Integrated Language Learning (CLIL) models in the European context is a fertile ground for the study of translanguaging. As noted above, taking the study of translanguaging beyond education contexts would be important.

Finally, our technological future will make more multimodal texts possible. Translanguaging research must take up multimodalities in order to understand how meaning is made as we integrate the very different modes of signification today – sound, image, print, different scripts, and language features. As research on translanguaging moves beyond classrooms, studies of translanguaging such as in texting, blogging, social media, gaming, and how these very different modes are simultaneously brought together to understand messages will be an important area of study.

---

## Conclusion

Translanguaging has moved from what seemed to be a neologism to describe diverse multilingual practices to a new critical analytical lens that deals with multilinguals' languages not as discrete and separated systems, but that form an integrated whole, a

repertoire that is accessed for specific communicative purposes. Translanguaging research is just beginning to emerge.

---

## Cross-References

- ▶ [Code-Switching in the Classroom: Research Paradigms and Approaches](#)
- ▶ [Ethnography of Language Policy](#)
- ▶ [Researching Globalization of English](#)
- ▶ [Researching the Continua of Biliteracy](#)

---

## Related Articles in the Encyclopedia of Language and Education

Ulrike Jessner-Schmid: [Translanguaging as a Pedagogical Tool in Multilingual Education](#). In Volume: Language Awareness and Multilingualism  
 Ofelia García and Angel M.Y. Lin: [Translanguaging in Bilingual Education](#). In Volume: Bilingual Educatio

---

## References

- Anton, M., & DiCamilla, F. (1998). Socio-cognitive functions of L1 collaborative interaction in the L2 classroom. *The Canadian Modern Language Review*, 54(3), 314–342.
- Baker, C. (2001/2011). *Foundations of bilingual education and bilingualism* (3rd ed.). Clevedon: Multilingual Matters.
- Barrett, C. (2012). Tu sabes que my flow so tight: Translanguaging as negotiated participation in classroom hip-hop media production. *Working Papers in Educational Linguistics*, 27(2), 79–96.
- Beres, A.M. (2014, January). *Translanguaging: A road to bilingually boosted education*. Poster presented at the 9th Annual Alpine Brain Imaging Meeting, Champéry.
- Bhabha, H. (1994). The location of culture. *London in New York: Routledge*.
- Canagarajah, S. (2011). Translanguaging in the classroom: Emerging issues for research and pedagogy. *Applied Linguistics Review*, 2, 1–27.
- Conteh, J., & Meier, G. (Eds.). (2014). *The multilingual turn in languages education: Opportunities and challenges*. Multilingual Matters.
- Cook, V. J. (1992). Evidence for multi-competence. *Language Learning*, 42(4), 557–591.
- Creese, A., & Blackledge, A. (2010). Translanguaging in the bilingual classroom: A pedagogy for learning and teaching? *Modern Language Journal*, 94(1), 103–115.
- Cummins, J. (2007). Rethinking monolingual instructional strategies in multilingual classrooms. *The Canadian Journal of Applied Linguistics*, 10(2), 221–240.
- Cummins, J. (2008). Teaching for transfer: Challenging the two solitudes assumption in bilingual education. In J. Cummins & N. H. Hornberger (Eds.), *Encyclopedia of language and education* (2nd ed., Vol. 5, pp. 65–75). New York: Springer.
- De Bot, K., Lowie, W., & Verspoor, M. (2007). A dynamic systems theory approach to second language acquisition. *Bilingualism Language and Cognition*, 10(1), 7–21.
- De Groot, A. M. B. (2011). *Language and cognition in bilinguals and multilinguals: An introduction*. New York: Psychology Press.



- Fitts, S. (2006). Reconstructing the status quo: Linguistic interaction in a dual-language school. *Bilingual Research Journal*, 29(2), 337–365.
- Flores, N., & García, O. (2013). Linguistic third spaces in education: Teachers' translanguaging across the bilingual continuum. In D. Little, C. Leung, & P. Van Avermaet (Eds.), *Managing diversity in education: Key issues and some responses* (pp. 243–256). Clevedon: Multilingual Matters.
- Fu, D. (2003). *An island of English. Teaching ESL in Chinatown*. Portsmouth: Heinemann.
- García, O. (2009). *Bilingual education in the 21st century: A global perspective*. Malden: Wiley/Blackwell.
- García, O., & Li Wei (2014). *Translanguaging: Language, bilingualism and education*. London: Palgrave Macmillan Pivot.
- García, O., Flores, N., & Woodley, H. H. (2012). Transgressing monolingualism and bilingual dualities: Translanguaging pedagogies. In A. Yiakoumetti (Ed.), *Harnessing linguistic variation for better education* (pp. 45–76). Bern: Peter Lang.
- Gort, M. (2006). Strategic codeswitching, interliteracy, and other phenomena of emergent bilingual writing: Lessons from first grade dual language classrooms. *Journal of Early Childhood Literacy*, 6(3), 323–354.
- Grosjean, F. (1982). *Life with two languages*. Cambridge, MA: Harvard University Press.
- Herdina, P., & Jessner, U. (2002). *A dynamic model of multilingualism*. Clevedon: Multilingual Matters.
- Hornberger, N. H., & Link, H. (2012). Translanguaging and transnational literacies in multilingual classrooms: A bilingual lens. *International Journal of Bilingual Education and Bilingualism*, 15(3), 261–278.
- Kenner, C. (2004). *Becoming biliterate: Young children learning different writing systems*. Trentham: Stoke on Trent.
- Lee, J. S., Hill-Bonnet, L., & Gillispie, J. (2008). Learning in two languages: Interactional spaces for becoming bilingual speakers. *International Journal of Bilingual Education and Bilingualism*, 11(1), 75–94.
- Lemke, J. (2002). Language development and identity: Multiple timescales in the social ecology of learning. In C. Kramsch (Ed.), *Language acquisition and language socialization* (pp. 68–87). London: Continuum.
- Lewis, G., Jones, B., & Baker, C. (2012a). Translanguaging: Developing its conceptualisation and contextualisation. *Educational Research and Evaluation*, 18(7), 655–670.
- Lewis, G., Jones, B., & Baker, C. (2012b). Translanguaging: Origins and development from school to street and beyond. *Educational Research and Evaluation*, 18(7), 641–654.
- Lewis, G., Jones, B., & Baker, C. (2013). 100 bilingual lessons: Distributing two languages in classrooms. In C. Abello-Contesse, P. Chandler, M. D. López-Jiménez, M. M. Torreblanca-López, & R. Chacón-Beltrán (Eds.), *Bilingualism and multilingualism in school settings*. Bristol: Multilingual Matters.
- Li Wei (2011). Moment analysis and translanguaging space: Discursive construction of identities by multilingual Chinese youth in Britain. *Journal of Pragmatics*, 43, 1222–1235.
- Lin, A. M. Y. (1999). Doing-English-lessons in the reproduction or transformation of social worlds? *TESOL Quarterly*, 33(3), 393–412.
- Lin, A. M. Y., & Martin, P. W. (Eds.). (2005). *Decolonisation, globalization: Language-in-education policy and practice* (Vol. 3). Clevedon: Multilingual Matters.
- López, A., Guzman-Orth, D., & Turkan, S. (forthcoming). *The use of translanguaging to assess the content knowledge of emergent bilingual students*. Princeton: Educational Testing Service.
- Martín-Beltrán, M. (2010). The two way language bridge: Co-constructing bilingual language learning opportunities. *Modern Language Journal*, 94(2), 254–277.
- Martínez-Roldán, C., & Sayer, P. (2006). Reading through linguistic borderlands: Latino students' transactions with narrative texts. *Journal of Early Childhood Literacy*, 6, 293–322.

- May, S. (Ed.). (2013). *The multilingual turn: Implications for SLA, TESOL, and bilingual education*. New York: Routledge.
- Moll, L. C., and Diaz, S. (1985). Promoting effective bilingual instruction. In: Garcia E. E, & Padilla R. V (eds). *Advances in Bilingual Education Research*. pp 127–225. Tucson: University of Arizona Press
- Sayer, P. (2013). Translanguaging, TexMex, and bilingual pedagogy: Emergent bilinguals learning through the vernacular. *TESOL Quarterly*, 47(1), 63–88.
- Shohamy, E. (2011). Assessing multilingual competencies. *The Modern Language Journal*, 95(3), 418–429.
- Swain, M. (2006). Languaging, agency and collaboration in advanced second language learning. In H. Byrnes (Ed.), *Advanced language learning: The contributions of Halliday and Vygotsky* (pp. 95–108). London: Continuum.
- Swain, M., & Lapkin, S. (2000). Task-based second language learning: The uses of the first language. *Language Teaching Research*, 4(3), 251–274.
- Velasco, P., & García, O. (2014). Translanguaging and the writing of bilingual learners. *The Bilingual Research Journal*, 37(1), 6–23.
- Williams, C. (1994). *Arfarniad o ddulliau dysgu ac addysgu yng nghyd-destun addysg uwchradd sdwyieithog*, [An evaluation of teaching and learning methods in the context of bilingual secondary education]. (Unpublished doctoral thesis). University of Wales, Bangor.
- Williams, C. (2012). *The national immersion scheme guidance for teachers on subject language threshold: Accelerating the process of reaching the threshold*. Bangor: The Welsh Language Board.

---

# Research Approaches to Narrative, Literacy, and Education

Gigliana Melzi and Margaret Caspe

---

## Abstract

Across cultures, oral narratives are woven into the fabric of everyday events and interactions. We tell stories to our peers as a way to establish and maintain friendships; caregivers tell stories to their children as a means to entertain and educate; and at school children and teachers share stories in the process of acquiring literacy. Narrative is a genre of oral discourse that combines various linguistic, cognitive, and social skills. Children's narrative development emerges from the early conversations between the child and adult caregivers, and their early narrative skills are predictive of various abilities related to future school success. This brief review synthesizes past and current research on children's oral narrative development and the connections between narrative abilities and other skills necessary for educational success. The review ends with a discussion of the challenges in conducting research with children's oral narratives, as well as future directions in the application of narrative work to educational interventions.

---

## Keywords

Narrative • Development • Education

---

G. Melzi (✉)

Applied Psychology, Steinhardt School of Culture, Education and Human Development, New York University, New York, NY, USA

e-mail: [gigliana.melzi@nyu.edu](mailto:gigliana.melzi@nyu.edu)

M. Caspe

Harvard Family Research Project, Harvard University, Cambridge, MA, USA

e-mail: [mcaspe@gmail.com](mailto:mcaspe@gmail.com)

## Contents

Introduction .....	242
Early Developments .....	242
Major Contributions .....	243
Work in Progress .....	247
Challenges and Future Directions .....	249
Conclusion .....	251
Cross-References .....	251
Related Articles in the Encyclopedia of Language and Education .....	251
References .....	251

## Introduction

Narratives rest at the core of human activity and relationships. Since ancient times, scholars and thinkers have conceptualized and analyzed narratives from diverse disciplinary perspectives. In this brief review, we define narrative as a genre of oral discourse that characterizes and facilitates culturally determined ways of communicating lived or imaginary events to others. We see narrative as a linguistic tool that represents ideas and past actions in memory, structures and evaluates present experiences, and helps humans make sense of the world around them. Loyal to this definition, narrative, literacy, and education are intimately intertwined, as early narratives lay the foundation for literacy development, and literacy, in turn, is the cornerstone of a successful formal education. Here we review past and current work addressing young children's narrative development and the connections between their oral narrative abilities and the skills necessary for their ultimate educational success.

## Early Developments

The study of oral narrative has its roots in structuralist investigations of written narrative. In one of the earliest works, *Morphology of the Folk Tale*, Propp (1928), a Russian scholar analyzed the basic plot components of fairy tales to derive their simplest irreducible narrative elements. Nonetheless, the most influential study for the contemporary narrative orientation used in the present review is the one conducted by Labov and Waletzky (1967). Their seminal work was presented in the spring of 1966 as a conference paper in the meeting of the American Ethnological Society. Breaking from the long-standing tradition of studying written narratives, Labov and Waletzky paved the way for the study of oral stories about personal experience, that is, of narratives in their everyday context. Their work focused mostly, as had Propp's (1928), on the structural aspects of narratives. They outlined the basic units of narrative analyses (e.g., clauses) and formulated their basic structure and organization (i.e., high-point analysis).

Although Labov and Waletzky's investigation was conducted with adults, it became a springboard for the study of children's conversational narratives. As

with adults, main questions of this early work focused on both the basic structural elements of children's narratives and how these were organized into a coherent and cohesive story. Within this field of research, two main perspectives emerged. In one view, scholars grounded in cognitive psychology conceptualized narratives as part of a larger cognitive domain, and, as such, they considered children's narrative abilities to be linked to the development of specific cognitive skills (e.g., Stein and Glenn 1979). In the second, scholars adopted a linguistic approach and viewed narratives as part of children's development of discourse abilities and, thus, linked to children's linguistic and conversational gains. Working from this latter perspective, Peterson and McCabe (1983) documented the developmental progression of children's narrative organization. Their work was instrumental in translating Labov and Waletzky's narrative analyses to children's oral stories and in examining the development of narrative organization as it approximated the canonical form of adult stories. Moreover, by developing a specific method of elicitation – *the conversational map*, in which an experimenter shares a personal experience and encourages children's narration of a similar experience through neutral prompting – their work opened the door for developmental narrative studies of children from different cultures.

Parallel to the interest in the development of children's narrative skills, the emergence of the ethnography of communication approach led to various naturalistic studies on children's language use, practices, and development in diverse communities around the world (see Vol. 8 and review by Garret, chapter “► [Researching Language Socialization](#),” this volume, for cultural perspectives on language learning). In these ethnographic studies, oral storytelling, or sharing stories about the past, emerged as a form of discourse used frequently with, around, or by children across societies. Yet, this early work also highlighted cultural variations in narrative realms (e.g., Heath 1983). For example, communities differ with regard to the frequency in which stories are shared, the socialization functions narratives play, and the roles adults and children play in the creation of stories. Heath's (1983) study on language and literacy development in three different sociocultural communities in the USA became a pivotal contribution to the field of education, namely, to the area focusing on the intersection between oral language and literacy. Her study highlighted how the purpose and practice of narrative sharing differ across communities and, more importantly, how narratives in classrooms can differ from those in the home. All children entering school must, therefore, adjust to the culture of the school if they are to become successful achievers in that milieu.

---

## Major Contributions

The last three decades have witnessed a surge in child narrative research. This work has been geared to describing developmental trajectories, identifying variations in narrative processes and outcomes, as well as examining the relation between children's oral narratives and the development of other skills, such as memory and literacy.

## Narrative Development

The first major line of inquiry, conducted primarily by developmental psychologists, concerns the development of narrative abilities. Relying on Vygotskian theory (1978) that highlights early social interaction between parents and children as a primary means by which children gain mastery of higher-order skills, research has documented change in children's narrative skills over time in conversations with experimenters or primary caregivers (see Schick and Melzi 2010 for a review). Through cross-sectional and longitudinal studies, we have learned that children begin to tell narratives at, approximately, age two. These early narratives are constructed in the context of everyday conversations with key adults such as parents, older siblings, and other family members. During these conversations, the more skilled conversational partner asks questions and provides statements about the experience that guide the child's construction of the experience into a meaningful narrative. At the early stages, most child-directed questions are "yes-no" (e.g., *Did Graham go to the park with mama?*). As children gain greater narrative competence, conversational partners request from them more complex information using open-ended questions (e.g., *What did you do at the park?*). Therefore, the contributions of others act as a scaffold for children's narratives by providing the information and the organization to construct a meaningful story that will be understood and valued by the larger society. As children develop, they internalize the structure modeled by adults and gain the ability to construct personal narratives independently.

By age 5, children are able to construct a basic narrative that approximates the canonical form of oral stories valued in their community. To tell a successful narrative, four basic skills need to be in place: (a) knowledge of the event to be discussed, (b) ways of weaving the events in a coherent manner, (c) language skills to represent the events in a cohesive manner, and (d) the ability to tailor the narrative to the specified audience. Numerous studies have focused on how children develop these four basic skills and incorporate them into their oral narratives across various story genres (for a review, see Schick and Melzi 2010).

## Individual, Linguistic, and Cultural Variations

A second major line of research investigates individual and cultural variations in children's narratives, as well as variations in the context of narrative development. Studies on children's independent storytelling have focused mostly on variations in their narrative discourse either as a function of culture-specific conventions of a good story or as a function of language typology and grammar (e.g., Berman and Slobin 1994). The majority of these studies prompt children to narrate wordless books or to construct narratives about past experiences. In recent years, there has also been an increase in the attention afforded to the narrative abilities of children growing up in multilingual communities. The research on bilingual narratives has evolved from examining a handful of children through case studies to including larger numbers of

children (e.g., Uccelli and Páez 2007), thereby increasing the generalizability of the findings. Overall findings suggest that some strategies are transferred across languages, such as overall narrative structure complexity and elaborativeness, and that skills in one language (i.e., the dominant language) might support the development of skills in the other language (Anstatt 2008).

Early studies on the context of narrative development focused predominantly on the discourse used by middle-class, English-speaking, European American parents and children during family reminiscing (i.e., conversations about personal past experiences). These studies identified elaborativeness – the extent to which parents provide or request new information – as a critical dimension of caregivers’ scaffolding discourse. During interactions with their children, some parents adopt a high-elaborative style, engaging in lengthy conversations about the past and asking numerous and varied questions, whereas other parents adopt a low-elaborative style, asking fewer and more redundant questions and providing less information to the child. The extent to which parents elaborate during narrative interactions has been associated with a range of developmental outcomes across time. Children of mothers who are highly elaborative tend to share longer, more descriptive personal narratives, have more developed receptive and productive vocabulary, concepts about print, and story comprehension skills, as well as better memory skills (for a comprehensive review, see Fivush et al. 2006).

Although to a lesser extent, parental narrative support has also been examined with families from other sociocultural and linguistic backgrounds. The early body of work documented variations in the topics discussed by parents and children, in the types and function of parental prompts, as well as the socialization functions of the narrative interactions. Miller and colleagues (e.g., Miller et al. 2005), for example, find that parents and children from working-class European American backgrounds engage in more co-narrations about the past than do European American dyads from middle-class backgrounds. However, children from working-class backgrounds are expected to provide factual accounts of the experience, whereas the children from middle-class families are allowed to express their own views whether these are factual or not. Recent research conducted with different cultural communities has incorporated various immigrant and nonimmigrant, as well as middle- and low-income, groups around the world. This work has combined the strengths of quantitative (i.e., larger sample sizes and advanced statistical analyses) and qualitative methods to examine the different types of stories valued by communities, as well as the diverse ways caregivers scaffold children’s storytelling in various narrative conversational contexts, including family reminiscing, talking about emotionally charged events, and birth stories, as well as the sharing of wordless and text-based picture books (e.g., Caspe 2009; Leyva et al. 2014; Melzi et al. 2011; Tōugu et al. 2011; Wang 2007). Overall researchers have concluded that societal values and ideological orientations (e.g., highlighting the self or others), as well as communicative patterns (e.g., communicating in subtle or direct ways), are responsible for culture-specific ways of organizing experiences into stories, as well the discourse parents use to support children’s developing narrative abilities.

## Predictive Value of Narratives

A third major line of research extends narrative study beyond the descriptive level to predict future educational outcomes. Most of this work has examined the connection between narratives and later literacy development, mostly reading acquisition. This work rests on the premise that oral narratives are a precursor to “academic language” – the language used in school, in writing, in public, and in formal settings (Snow and Uccelli 2009, p. 112). Narratives are a form of extended discourse that requires children to move beyond the observable and create meaning solely through language. The use of language in such a manner during the preschool years is a powerful predictor of children’s future use of school-related literacy because texts presented for comprehension in the school setting typically demand children to interpret complex messages without the support of a conversational partner or shared knowledge with an audience (Dickinson and Tabors 2001). Extensive research has shown that both the length and quality of young children’s narratives positively predict preparedness for reading, including phonological awareness, print concepts and vocabulary, as well as future reading fluency and comprehension (Reese et al. 2010c).

The importance of narratives for children’s ultimate academic success also resides in the fact that the school context is an environment in which children must listen to and exchange their own stories as part of interactions with both teachers and peers. Difficulty with storytelling, therefore, might ultimately manifest itself in the classroom environment in terms of poorer language and cognitive skills, as well as poorer social interactions. Yet, the seminal work of Cazden (1988) underscores that classroom discourse privileges a culture-specific narrative style. Children whose home literacy and narrative interactions more closely resemble what occurs in the classroom tend to enjoy greater success in school than those children whose and literacy skills have been attained through everyday experiences that differ from school-like interactions. Teachers might fail to acknowledge the narrative style children bring to bear on their education and, in turn, negatively influence their ability to achieve. More recent work in this line of research has shown positive relations between culture-influenced features of oral narratives and reading skills (Curenton 2011).

Narrative is also associated with skills such as abstract thought processes, representational development, the construction of knowledge bases, and problem-solving strategies. Much of the research on narrative has examined its relation to the organization of memories, in particular, autobiographical memory (Fivush 2011). Autobiographical memory is defined as the component of memory that holds all key experiences related to building a concept of self. Therefore, personal narratives are not only a critical aspect of memory, but also the link between memory and the development of self. In narrating stories about past experiences, children are learning to organize their lived experiences into a coherent narrative of self, weaving factual information with their subjective interpretation of the experience. Fivush and colleagues, for example, argue that the subjective or evaluative aspect of narratives links personal memories and the development of a self-concept. Numerous studies have shown a predictive relation between narrative, memory processing, and



construction of self across diverse age groups and in various cultures (e.g., Fivush 2011). Taken together, this work shows that “each of us creates a life narrative embedded in sociocultural frameworks that define what is appropriate to remember, how to remember it, and what it means to be a self with an autobiographical past” (Fivush and Haden 2003; p. viii).

---

## Work in Progress

As educators focus on school readiness and the concept of literacy more broadly, narratives emerge as a compelling and powerful tool through which to understand various aspects of children’s development across diverse contexts. Two new lines of research have emerged in narrative work in the recent years.

## Extending Narratives Beyond the Home

Children’s narrative competencies are influenced by the setting in which they develop. For the most part, research has concentrated on how children develop narrative through conversations with family members in the home during either structured or unstructured tasks (e.g., at mealtime, during book reading or playing with toys). In recent years, however, research has begun to explore how children’s conversations with adults in different contexts, beyond the home, also contribute to the content and complexity of narrative and linguistic skills. For example, although studies looking at the relation between teacher language and children’s outcomes in the classroom setting are not new (Dickinson and Tabors 2001), recent research has begun to study the specific effects that teacher narrative discourse can have on literacy development, especially in relation to the extent to which teachers’ narratives style align or are discordant with styles that exist in the home (Schick 2014).

The museum has also been identified as a context that fosters children’s narrative discussions related to science, technology, engineering, and math (STEM) concepts. A brief experiment designed to enhance family interactions in a STEM-related children’s museum exhibit increased the ways that families talked with children about science learning and also increased the types of STEM-related content children and families discussed (Haden et al. 2014). Further, through the resources and books offered and the types of trainings provided, libraries are also important contexts for narrative development. Neuman and Celano (2012), for instance, show that families of varied socioeconomic backgrounds support their children’s literacy and narrative skills in different ways in the library setting. Lastly, digital media presents a context ripe for investigating as a scaffold for children’s narrative development. Children age 8 and under spend on average nearly 2 h a day with screen media, with an increasing amount of this time spent in mobile media platforms and applications (Common Sense Media 2013). Although most apps that focus on language and literacy development emphasize alphabet knowledge and letter sound skills, there are many that also seek to cultivate children’s

storytelling and narrative abilities (Guernsey et al. 2012). While it is not yet clear how these digital storytelling apps specifically improve children's narrative skills, it is possible that through the varied conversations children may have with parents while engaged with these apps and the types of narrative sequencing, character creation, and event development they require, children will come to have a richer and more varied sense of how narratives unfold.

## **Narratives and Children's Socio-cognitive Skills**

A second line of contemporary research explores the relation between children's narrative and social cognitive skills, in particular theory-of-mind (ToM) development (Gamannossi and Pinto 2014; Taumoepeau and Reese 2013). Theory of mind (ToM) is a milestone in children's socio-cognitive development emerging around the age of 4 and encompassing a range of abilities, including the ability to see another's point of view, to ascribe mental states (e.g., desires, beliefs, intentions, and emotions) to others, and to use this information to predict others' behavior. Findings from developmental studies show that individual differences in children's theory of mind are related to several aspects of social functioning, including prosocial behavior, peer acceptance, and successful communication with friends (Hughes and Leekam 2004), which in turn have been found to be powerful predictors of academic outcomes (Wentzel 2009).

There is a clear relation between children's language abilities and ToM understanding. However, the nature and direction of the relationship between children's ToM and narrative development is not fully understood. While some studies propose that narrative skills require a certain level of ToM understanding, others suggest that narrative skills are necessary for advancing ToM development (see Fernández 2013, for a review). Future research is needed to better understand how an improved understanding of others' intentions, beliefs, desires, and emotions improves narrative skills and how development of narrative skills influences children's abilities to think about others' internal states and abilities to engage in effective social interaction which are a critical component of school success.

In recent years, though, researchers have also sought to link narratives to another socio-cognitive skill that also develops in the preschool years – executive function. Executive function refers to the ability to control one's behavior, to maintain attention, to utilize working memory effectively, and to be able to think flexibly about various concepts at the same time (Diamond 2012). Executive functioning is critical for school success and can be improved with intervention and training. Since narrative development is related to ToM and aspects of ToM are associated with executive functions (Devine and Hughes 2014), it follows that narrative development and executive functions might also be interdependent. Recent findings do in fact suggest that the ability to sustain attention at 4 years of age supports later narrative competency, and, likewise, narrative ability at 4 years of age supports facility and speed in learning and implementing new rules as measured by executive function tasks (Friend and Bates 2014).

## Challenges and Future Directions

Two major challenges in the narrative literature include defining and assessing narrative skills in children and translating the knowledge gained in research studies into successful practices and interventions. In addressing these two main problems, basic research in narrative development can be applied in a manner that might lead to the improvement of educational prospects for all children.

## Defining and Assessing Narratives

A major problem in narrative inquiry is that of definition and assessment. Numerous factors need to be considered in obtaining narrative data, such as the type of narrative to elicit, the degree to which supports (e.g., books, pictures, conversational partner) will be included in the assessment, who will listen to the stories that are produced (e.g., experimenter, familiar adult, peer), and how the collected narratives relate to demands of the children's home culture as well as those of the mainstream community. A variety of narrative assessment procedures have been used in research over the past 30 years. These include, but are not limited to, production of fictional stories in response to open-ended prompts, retelling of a story with or without visual prompts, sharing a story about a personal experience from the past, response to structured prompts in which children reply to questions about a picture or story, storytelling with wordless books either with or without adult scaffolding, adult-child conversations, response to picture tasks whereby children spontaneously talk about the pictures they see (e.g., TAT), and play narration where children are provided a set of play animals and introduced to a verbal conflict and asked to tell the rest of the story.

Likewise, throughout the last 30 years, multiple methods for narrative analyses have been used depending on investigators' method of elicitation, definition of narrative, theoretical stance, and focus of study. Narrative scholars have attempted to provide an integrative framework for analyzing narratives. For example, McCabe and Bliss (2003) suggest four main types of analyses that surface different narrative abilities and features: high-point microanalysis, story grammar analysis, stanza analysis, and narrative assessment profile. High-point microanalysis assesses specific aspects of narrative (e.g., the presence of an opening, complicating actions, evaluation) to provide a window into a child's overall narrative structure. Story grammar analysis is used in evaluation of fictional stories by examining explicit goals of a protagonist. Stanza analysis involves breaking narratives into sentences or phrases and grouping these phrases into stanzas to understand subtopics of a larger discourse. Finally, narrative assessment profile evaluates discourse coherence including topic maintenance, event sequencing, informativeness, referencing, cohesion, and fluency.

Although narrative tasks are easy to administer, a major drawback of narrative research is that it involves labor-intensive procedures for collecting, transcribing, coding, scoring, and analyzing data. In recent years, researchers, educators,

psychologists, and policy makers in the field of early childhood have become interested in translating approaches to narrative analysis into standard assessments for large-scale research and intervention projects. This interest is due, in part, to the unique ability of a narrative to tap into multiple dimensions of children's developing capacities at once. Both educators and researchers argue that although many approaches exist for collecting and analyzing data, a more standard approach for administration, coding, and analysis is needed to alleviate the burdens of time, cost, and training, as well as to ensure the collection of reliable and valid data across a range of settings (e.g., preschools, center-based and home-based programs, family day care). That is, narrative is still mostly a psychologist or language researcher's tool, with little crossover to educational practice. Few standardized assessments exist to measure narrative ability with notable exceptions including the Index of Narrative Complexity [INC], Petersen et al. 2008), the Narrative Assessment Protocol [NAP] (Justice et al. 2010), and the Narrative Scoring Scheme (Heilmann et al. 2010). However, as most of these have been developed for English-speaking children in the USA, more culturally appropriate standardized tests, as well as those appropriate for multilingual children, are needed to allow teachers and large-scale researchers who work with diverse populations to include narrative analysis in their work more readily.

## **Implementation of Research: Intervention**

Because of the importance of narrative for different domains of children's development, researchers have designed narrative-based interventions to improve children's reading readiness. Most of these interventions have targeted families of low-income children, disproportionately at risk for reading failure in the later years (Reese et al. 2010b; but see Petersen 2011 for a comprehensive review of narrative interventions with children who have language impairment). One intervention that has been shown to be effective at building early literacy skills is Dialogic Reading – a book reading intervention program that encourages parents and teachers to elicit information from their children and to foster their active participation (Whitehurst and Lonigan 1998). A second type of intervention that has shown to be effective in supporting children's reading readiness development has focused on supporting parent to be more elaborative during family reminiscing (Peterson et al. 2003; Reese and Newcombe 2007). Together, these two types of interventions have been shown to improve a range of children's early literacy, language and narrative skills, as well as metalinguistic abilities (Reese et al. 2010a; Zevenbergen and Whitehurst 2003). Recent research, however, seems to suggest that the benefits of parent interventions targeting family reminiscing have a wider reach than those centered around book sharing (Reese 2012). Mol et al. (2008), for example, showed that dialogic reading is particularly beneficial for middle-class families, and Reese et al. (2010a) showed that dialogic reading, in fact, decreased the quality of the narratives told by children from low-income ethnic diverse families. A possible explanation for the lack of effectiveness of the parenting interventions, especially for

low-income families, is that they are more difficult to implement and evaluate for various logistical reasons such as parents' work schedules and the ability of intervention staff to implement curriculum consistently. A second plausible explanation is that the interaction styles encouraged through the intervention programs are not necessarily aligned with the narrative practices of the home and thus are not building on the cultural assets of the families. Thus, more research is needed to examine whether interventions targeting caregivers' reminiscing style are more effective for low-income, ethnically diverse families. In addition, there is a need to refocus interventions to target childhood educators instead of parents as a way to improve the educational prospects of low-income ethnically diverse children.

---

## Conclusion

In this brief review, we synthesized past and current research on children's narrative development and the possible connections between children's oral narrative abilities and other skills necessary for academic success. Storytelling is a complex ability combining various linguistic, cognitive, and social skills. Consequently, narrative is associated with various areas of academic achievement, such as language and literacy, memory skills, and a host of socio-cognitive abilities. The study of narrative has a long history that has built on the successes of investigations in various disciplines, including linguistics, literary studies, anthropology, and psychology. Throughout the progression of this scholarly work, narratives emerge as a window into individuals' selves and their communities.

---

## Cross-References

- ▶ [Linguistic Ethnography](#)
- ▶ [Narrative Inquiry and Multicultural Education](#)
- ▶ [Researching Language Socialization](#)

---

## Related Articles in the Encyclopedia of Language and Education

Patricia A. Duff and Stephen May (eds): [Encyclopedia of Language and Education, Language Socialization](#). In Volume: Language Socialization

---

## References

- Anstatt, T. (2008). Aspect and tense in storytelling by Russian, German and bilingual children. *Russian Linguistics*, 32, 1–26.
- Berman, R. A., & Slobin, D. I. (1994). *Relating events in narrative*. Hillsdale: Erlbaum.

- Caspe, M. (2009). Low-income Latino mothers' booksharing styles and children's emergent literacy development. *Early Childhood Research Quarterly*, 24, 306–324.
- Cazden, C. B. (1988). *Classroom discourse*. Portsmouth: Heinemann.
- Common Sense Media. (2013). *Zero to eight: Children's media use in America 2013*. <https://www.commonsensemedia.org/research/zero-to-eight-childrens-media-use-in-america-2013>. Accessed 2 June 2015.
- Curenton, S. (2011). Understanding the landscapes of stories: The association between preschoolers' narrative comprehension and production skills and cognitive abilities. *Early Child Development and Care*, 181(6), 791–808.
- Devine, R. T., & Hughes, C. (2014). Relations between false belief understanding and executive function in early childhood: A meta-analysis. *Child Development*, 85(5), 1777–1794.
- Diamond, A. (2012). Activities and programs that improve children's executive functions. *Current Directions in Psychological Science*, 21(5), 335–341.
- Dickinson, D. K., & Tabors, P. O. (2001). *Beginning literacy with language: Young children learning at home and school*. Baltimore: Brookes.
- Fernández, C. (2013). Mindful storytellers: Emerging pragmatics and theory of mind development. *First Language*, 33, 20–46.
- Fivush, R. (2011). The development of autobiographical memory. *Annual Review of Psychology*, 62(5), 559–582.
- Fivush, R., & Haden, C. A. (2003). *Autobiographical memory and the construction of a narrative self: Developmental and cultural perspectives*. Mahwah: Erlbaum.
- Fivush, R., Haden, C. A., & Reese, E. (2006). Elaborating on elaborations: Role of maternal reminiscing style in cognitive and socioemotional development. *Child Development*, 77(6), 1568–1588.
- Friend, M., & Bates, R. P. (2014). The union of narrative and executive function: Different but complementary. *Frontiers in Psychology*, 5, 469. doi:10.3389/fpsyg.2014.00469.
- Gamannossi, B. A., & Pinto, G. (2014). Theory of mind and language of mind in narratives: Developmental trends from kindergarten to primary school. *First Language*, 34(3), 262–272.
- Guemsey, L., Levine, M., Chiong, C., Severns, M. (2012). *Pioneering literacy in the digital wild west: Empowering parents and educators*. [http://gradelevelreading.net/wp-content/uploads/2012/12/GLR\\_TechnologyGuide\\_final.pdf](http://gradelevelreading.net/wp-content/uploads/2012/12/GLR_TechnologyGuide_final.pdf). Accessed 2 June 2015.
- Haden, C. A., Jant, E. A., Hoffman, P. C., Marcus, M., Geddes, J., & Gaskins, S. (2014). Supporting family conversations and children's STEM learning in a children's museum. *Early Childhood Research Quarterly*, 29, 333–344.
- Heath, S. B. (1983). *Ways with words*. Cambridge: Cambridge University Press.
- Heilmann, J., Miller, J. F., & Nockerts, A. (2010). Sensitivity of narrative organization measures using retells produced by young school-age children. *Language Testing*, 27(4), 603–626.
- Hughes, C., & Leekam, S. (2004). What are the links between theory of mind and social relations? Review, reflections and new directions for studies of typical and atypical development. *Social Development*, 13, 590–619.
- Justice, L. M., Bowles, R., Pence, K., & Gosse, C. (2010). A scalable tool for assessing children's language abilities within a narrative context: The NAP. *Early Childhood Research Quarterly*, 25, 218–234.
- Labov, W., & Waletzky, J. (1967). Narrative analysis: Oral versions of personal experience. In J. Helm (Ed.), *Essays on the verbal and visual arts* (pp. 12–44). Seattle: University of Washington Press.
- Leyva, D., Berrocal, M., & Nolivós, V. (2014). Spanish-speaking parent–child emotional narratives and children's social skills. *Journal of Cognition and Development*, 15(1), 22–42.
- McCabe, A., & Bliss, L. S. (2003). Patterns of narrative discourse: A multicultural, life span approach. Allyn & Bacon.
- Melzi, G., Schick, A., & Kennedy, J. (2011). Narrative participation and elaboration: Two dimensions of maternal elicitation style. *Child Development*, 82(4), 1282–1296.
- Miller, P. J., Cho, G. E., & Bracey, J. R. (2005). Working-class children's experience through the prism of personal storytelling. *Human Development*, 48, 115–135.

- Mol, S. E., Bus, A. G., de Jong, M. T., & Smeets, D. J. H. (2008). Added value of dialogic parent-child book readings: A meta-analysis. *Early Education and Development, 19*(1), 7–26.
- Neuman, S. B., & Celano, D. C. (2012). Worlds apart: One city, two libraries, and ten years of watching inequality grow. *American Educator, 36*, 13–23.
- Petersen, D. B. (2011). A systematic review of narrative-based language intervention with children who have language impairment. *Communication Disorders Quarterly, 32*(4), 207–220.
- Petersen, D. B., Gillam, S. L., & Gillam, R. B. (2008). Emerging procedures in narrative assessment. *Topics in Language Disorders, 28*(2), 115–130.
- Peterson, C., & McCabe, A. (1983). *Developmental psycholinguistics*. New York: Plenum.
- Peterson, C., McCabe, A., & Jesso, B. (2003). Parents as teachers of preliteracy skills. In A. McCabe & L. S. Bliss (Eds.), *Patterns of narrative discourse* (pp. 179–188). Boston: Pearson.
- Propp, V. I. (1928/1968). *Morphology of the Folktale* (trans: L. Scott, 2nd ed.). Austin: University of Texas Press.
- Reese, E. (2012). The tyranny of shared book-reading. In S. Suggate & E. Reese (Eds.), *Contemporary debates in childhood education and development* (pp. 58–68). Florence: Routledge.
- Reese, E., & Newcombe, R. (2007). Training mothers in elaborative reminiscing enhances children's autobiographical memory and narrative. *Child Development, 78*(4), 1153–1170.
- Reese, E., Leyva, D., Sparks, A., & Grolnick, W. (2010a). Maternal elaboration reminiscing increases low-income children's narrative skills relative to dialogic reading. *Early Education and Development, 21*(3), 318–342.
- Reese, E., Sparks, A., & Leyva, D. (2010b). A review of parent interventions for preschool children's language and emergent literacy. *Journal of Early Childhood Literacy, 10*(1), 97–117.
- Reese, E., Suggate, S., Long, J., & Schaughency, E. (2010c). Children's oral narrative and reading skills in the first 3 years of reading instruction. *Reading & Writing, 23*, 627–644.
- Schick, A. R. (2014). Home-school literacy experiences of Latino preschoolers: Does continuity predict positive child outcomes? *Journal of Applied Developmental Psychology, 35*, 370–380.
- Schick, A., & Melzi, G. (2010). Children's oral narrative development across contexts. *Early Education & Development, 21*(3), 293–317.
- Snow, C. E., & Uccelli, P. (2009). The challenge of academic language. In D. R. Olson & N. Torrance (Eds.), *The Cambridge handbook of literacy* (pp. 112–133). Cambridge: Cambridge University Press.
- Stein, N. L., & Glenn, C. (1979). An analysis of story comprehension in elementary school children. In R. D. Freedle (Ed.), *Advances in discourse processes: New directions in discourse processing* (Vol. 2, pp. 53–119). Norwood: Albex.
- Taumoepeau, M., & Reese, E. (2013). Maternal reminiscing, elaborative talk, and children's theory of mind: An intervention study. *First Language, 33*(4), 388–410.
- Tōugu, P., Tulviste, T., Schröder, L., Keller, H., & De Geer, B. (2011). Socialization of past event talk: Cultural differences in maternal elaborative reminiscing. *Cognitive Development, 26*, 142–154.
- Uccelli, P., & Páez, M. (2007). Narrative and vocabulary development of bilingual children from kindergarten to first grade. *Language, Speech, and Hearing Services in Schools, 38*, 225–236.
- Vygotsky, L. S. (1978). *Mind in society*. Cambridge, MA: Harvard University Press.
- Wang, Q. (2007). "Remember when you got the big, big bulldozer?" Mother-child reminiscing over time and across cultures. *Social Cognition, 25*(4), 455–471.
- Wentzel, K. R. (2009). Peers and academic functioning at school. In K. H. Rubin, W. Bukowski, & B. Laursen (Eds.), *Handbook of peer interactions, relationships, and groups* (pp. 531–547). New York: Guilford.
- Whitehurst, G. J., & Lonigan, C. J. (1998). Child development and emergent literacy. *Child Development, 69*(3), 848–872.
- Zevenbergen, A. A., & Whitehurst, G. J. (2003). Dialogic reading: A shared picture book reading intervention for preschoolers. In A. van Kleeck, S. A. Stahl, & E. B. Bauer (Eds.), *On reading books to children* (pp. 170–192). Mahwah: Erlbaum.

---

# Second Language Acquisition and Identity

Viniti Vaish

---

## Abstract

This chapter introduces the field of second language acquisition (SLA) and identity with a focus on the main topics prevalent in this field and the research methods used by scholars. Beginning with some seminal works in the early 1970s, this field has gained increasing importance. Resilient concepts regarding the study of identity and language include “acts of identity,” resistance, and investment rather than motivation and the idea that attitudes toward speakers of another language are formed at an early stage. Typically studies in this area have focused on immigrants in first world countries like the USA and UK who make tremendous investments in language learning. However, a new trend in this area is the emergence of studies which look at language learning in Asian contexts, such as Singapore and Malaysia, where English is either the sole medium of instruction or the medium of instruction for a few subjects. Scholars tend to lean more toward qualitative methods of data collection in this field, favoring case studies and ethnographies, though there do exist a few studies in which a large-scale survey is the main instrument of data collection. I will introduce this chapter with a few incidents from my own professional life that have shaped my identity as a language learner and teacher. Thereafter I go on to discuss topics in the literature which have longevity, in other words, topics that keep occurring in the literature over decades of research. Following this is a section on the best-known works in the field of SLA and identity and, thereafter, topics that are currently being debated in the field. At the end of the chapter, I focus on problems faced by scholars in this field and finally future directions.

---

V. Vaish (✉)

English Language and Literature Academic Group, National Institute of Education, Nanyang Technological University (NIE/NTU), Singapore, Singapore  
e-mail: [viniti.vaish@nie.edu.sg](mailto:viniti.vaish@nie.edu.sg)



---

**Keywords**

 Identity • Investment • Motivation • Resistance • Language learning
 

---

**Contents**

Introduction .....	256
Early Developments .....	257
Major Contributions .....	260
Work in Progress .....	262
Problems and Difficulties .....	263
Future Directions .....	264
Conclusion .....	265
Cross-References .....	265
Related Articles in the Encyclopedia of Language and Education .....	265
References .....	265

---

**Introduction**

Two incidents from my life come to mind as I reflect on the issue of identity and SLA. One is regarding my very first job: a rhetoric and composition tutor in an American university from 1987 to 1989. At that time, when I was in my mid-20s, I was hired to teach composition to undergraduate engineering students, a compulsory course for them that they hated. What I remember about those 2 years is struggling with my own identity as an Indian tutor teaching writing to an all-white class of youngsters and the perception of my class that a “nonnative” speaker of English was teaching “native speakers” how to write in “their own” language.

The second incident occurred during data collection for my dissertation Vaish (2004). I was visiting the Sarvodaya Kanya Vidyalaya (Sarvodaya Girls School) in East Delhi regularly for data collection. The Sarvodaya School has two streams: an English- and a Hindi-medium stream. Often I sat with the teachers in the staff room and had informal conversations with them about the students. In one of these conversations, a teacher remarked that there is a difference between the girls in the Hindi- and English-medium streams in terms of aptitude: only the brightest girls were sent to the English-medium stream. The others were in Hindi medium because they would not be able to cope with science and history textbooks in English, even though the teachers explained the content of these texts in Hindi. In one of these conversations, a teacher made the following remark: “The girls in English medium are different. They look different. They even walk differently.”

The teacher’s remark was about SLA and identity. What she meant was the girls in Sarvodaya School, who were in the English-medium stream, gained a confidence due to the fact that they were acquiring a global language of power that could lead to professional development. As all the students of the Sarvodaya School, many of whom were first-generation school goers, came from disadvantaged homes, this newfound confidence acquired due to learning a new language was as important as language acquisition itself.

My experience in an Indian school emphasized how second language learning, though a skill necessary for academic achievement, is never merely a skill but the acquisition of a new and transformed identity. At the same time, my experience of teaching in an American university reminded me that for those who are deemed “native speakers” the perception of this identity is vastly different from what the second language learner thinks of himself/herself. The contestation of differing perceptions and attitudes toward identity and the contestations between “native speakers” or the purported owners of a language and the learners of the same language make this field both interesting and provocative.

---

## Early Developments

Resilient concepts regarding the study of identity and SLA include “acts of identity,” investment, and resistance rather than motivation and the idea that attitudes toward speakers of another language are formed at an early stage. By the word “resilient” I mean concepts that remain important in the literature across decades though the sample or subjects on which these concepts are applied may change. In the following paragraphs, I will discuss each of these key concepts as they comprise the bedrock of the literature on SLA and identity.

One of the most cited works on identity is LePage and Tabouret-Keller (1985), who suggested that identity is revealed through language. They used the phrase “acts of identity,” meaning that identity is not a static set of attributes though at first we might perceive it to be so. For instance, we might perceive an individual to be a male; Indian, from North India; and Hindi-English bilingual who believes in the supremacy of the Hindi language. But these attributes should be revealed through speech acts (e.g., requests) or speech events (e.g., asking for information) if a linguist has to prove that this is indeed the identity of that Indian individual. The theoretical framework of “acts of identity,” formulated in the 1980s, on data that LePage and Tabouret-Keller collected from the countries of Belize and St. Lucia, was in the tradition of variationist sociolinguistics and creole studies. The “acts of identity” model predicted a specific behavior from speakers. The model posited that speakers behave according to the speech and behavior of groups they want to identify with and speakers can identify these desirable groups, have access to them, are motivated to join them, and have the ability to change their own behavior. On this basis, LePage and Tabouret-Keller found five clusters of speakers in Belize and eight in St. Lucia. The strength of the “acts of identity” model is that it privileges a mixed methodology in research design. Though the survey was analyzed quantitatively, the authors also took the history and social fabric of Belize and St. Lucia into account while analyzing their data.

Although LePage and Tabouret-Keller (1985) contributed a seminal work to research on identity and language, their heuristic still results in creating groups without hybridity that, in today’s globalized world, is not sustainable (Nero 2005). For example, Nero pointed to the limitations of labels like the native and nonnative speaker dichotomy, English language learners (ELL), and other such monikers that

do not do justice to the rich and changing identities that students bring to the language learning classroom. According to Nero, a more holistic way of representing the hybridity of postcolonial identities is Rampton's (1990) framework which comprises three distinct categories: language expertise, language affiliation, and language inheritance. The first refers to proficiency, the second to desire, and the third to what we inherit in terms of language from our families, whether or not we have expertise in our inherited language or whether or not we desire to be part of what we have inherited.

Typically the concept of motivation in language learning is isolated from the contributions of identity, culture, and personal history, an approach challenged by Pierce (1995). Pierce, in a seminal article, argued that SLA looks at the language learner in isolation, without an integrative theoretical framework that links the learner with the learning context. To address this knowledge gap, Norton proposed a theory of social identity and substantiated this through a longitudinal qualitative study of five immigrant women learning English in Canada. She coined the concept "investment" as an alternative to motivation. The difference between motivation and investment is that "motivation is a property of the language learner—a fixed personality trait. The notion of investment, on the other hand, attempts to capture the relationship of the language learner to the changing social world" (p. 17). Investment situated the learner within a cultural and linguistic ecology in which the desires of the learners could keep changing depending on how they wanted to be perceived by society and by themselves. Norton's research was linked to the classroom on the basis of classroom-based social research (CBSR). She defined CBSR as "collaborative research that is carried out by language learners in their local communities with the active guidance and support of the language teacher" (p. 26). Studies on motivation, even today, tend to be largely quantitative in nature and are conducted by scholars with a background in psychology. Though valuable these studies offer a unidimensional view of the language learner as highly motivated or not motivated. The concept of investment requires a qualitative methodology to locate the desires of learners embedded in their histories and cultures. For instance, Norton (1995) analyzed the diary entries of her five participants to trace how their identity changed in response to their language learning environment.

Lambert and Tucker's (1972) longitudinal study is a voluntary, community-based Canadian project in which French was used as the language of instruction for children (Grades 1–4) who came from English speaking homes. The student participants' achievement and attitudes were compared with children who came from French speaking homes. Lambert and Tucker knew from previous research "how important the language learner's attitudes toward the 'other' ethnolinguistic group can be in determining one's success in acquiring that group's language, quite independently of the student's linguistic aptitude or verbal intelligence" (p. 154). They found that even in Grade 1 the children who came from English speaking homes developed a more democratic and open-minded perception of French people and their culture and that this was partly due to their immersion in the French language and interaction with French teachers. Similar to Lambert and Tucker's

work, Downes (2001) looked at cultural identity of bilingual students in an Asian context. He compared the attitudes of two groups of students in Japan: (1) secondary school students in an English immersion program and (2) secondary students in a regular program who were learning English as a second language. The main instrument of data collection was the Attitude Towards Japan and the West Questionnaire (AJWQ). Despite the concern of parents that students in the immersion program would lose their Japanese identity, Downes found that not only was this not the case but students in the immersion program developed more flexible attitudes and their scores were comparable to the children in the regular program, thus corroborating what Lambert and Tucker had found in their study.

In the mid-1990s, there was a spate of special issues on identity (Martin-Jones and Heller 1996; Sarangi and Baynham 1996), testifying to the increasing popularity of this topic in language learning. One of the themes that stood out for me from these and other articles that followed these was that of resistance. The idea of resistance was probably a concern for these scholars because they wanted SLA to acknowledge the presence of agency in the learner. They thought of the learner, not as an empty receptacle to be filled with the knowledge of the teacher, but as an active participant who could evaluate his/her own language learning experience.

Second language (L2) learners are never passive consumers of a linguistic product; rather, their efforts to learn a second language are mediated by their perceptions of the specific culture that the new language symbolizes. More often than not, L2 learners display contradictory behavior by resisting and also being drawn to the L2 they are learning (Canagarajah 1993; Liu and Tannacito 2013; Norton 2001). While teaching English as a second language (ESL) in Sri Lanka, Canagarajah found that students favored the product-oriented, grammar-based approaches to learning English and avoided communicating in English. Sri Lankan students felt that by communicating in English, they were pretending to be the bourgeois and thus were being disrespectful to their own Tamil language and ethnic group.

On the other hand, Liu and Tannacito (2013) argued that Taiwanese students of English display a White Prestige Ideology (WPI), which the authors described as “a personal fantasy toward the white languages/people/cultures” (p. 357). They defined WPI as both discourse and social practice that perpetuates the unequal power relations between American teachers and Taiwanese students through the processes of inferiorization. Through in-depth interviews with two Taiwanese students, Liu and Tannacito found that the students were not happy with Taiwanese or other non-American teachers of English as they considered these teachers substandard. With such teachers, the students showed resistance because such teachers could not teach them the American way of writing that would give them access to an imagined community of prestige in academia.

Early work in SLA and identity thus not only popularized major concepts in this field but also problematized them. For instance the concepts of attitude and motivation, though crucial for understanding SLA, were problematized by overlapping concepts of investment and agency, which created a fertile ground for future studies in this area.

## Major Contributions

One of the most referenced works in the field of SLA and identity is Norton's (2000) *Identity and Language Learning: Gender, Ethnicity and Educational Change*. The problem, according to Norton, at the time of writing this book was that SLA theorists had not developed a theory of identity that integrated the language learner with the language learning context. In this context, power is inequitably distributed and social interactions do not give second language learners the autonomy and benefits that are enjoyed by native speakers. It is this theoretical gap, and its concomitant methodological conundrums, that Norton was grappling with. In this book, Norton used the term identity "to reference how a person understands his or her relationship to the world, how that relationship is constructed across time and space, and how the person understands possibilities for the future" (p. 5). In a memorable statement, Norton wrote: "I take the position that identity references desire – the desire for recognition, the desire for affiliation and the desire for security and safety" (p. 8).

In suggesting what would be the most appropriate methodology for analyzing issues on this topic, Norton (2000) drew on the work of educational researchers in the fields of cultural studies, feminism, and critical ethnography. Rejecting the view that any research can claim to be objective or unbiased, Norton, in her own research with immigrant language learners in Canada, used a more qualitative approach and frequently asked questions about race, gender, and social class. Norton recommended a relationship between the researcher and the researched characterized by "research that is on, for and with subjects" (p. 23). The common methods of data collection tend to be ethnographies, interviews, diary studies, and participant observations.

Two edited volumes have made substantial contributions to the field of SLA and identity: Kubota and Lin (2009) and Cox et al. (2010). Kubota and Lin observed that English language teaching brings together many different races; however, TESOL has typically ignored "race" as an important aspect in the enterprise of language learning. They pointed out that the concept of race typically means differences between groups of people based on phenotypical features like skin color. However, the numbers of genes between human beings that are actually different are very few. According to some studies, only 0.5% of genes in the human body account for differences in phenotype. Thus there are far more similarities between races than differences, and the idea of different races is more imagined than real. Yet, race is a very real ideological concept that drives the motivations and aspirations of human beings. Since phenotype does not lend itself to empirically proven differences between groups of people, it is possible that the difference is more one of identity, which is socially constructed, than race which is physically constructed.

Both race and ethnicity are integrally linked to ideology in the field of SLA. According to Kubota and Lin (2009), "the problem lies in the tendency to equate the native speaker with white and the nonnative speaker with nonwhite." (p. 8). Due to this underlying problem, two important theoretical orientations for investigating issues of race in the teaching and learning of English are critical race theory (CRT) and critical white studies. These orientations unpack the physical and ideological

space dominated by race and the privileging of “whiteness.” The term critical white studies refers to the importance given to the cultures and lifestyles of middle-class white people, specifically the importance given to pedagogies of English language learning, textbook content, and assessment which are produced in inner circle countries. The methodological tool in CRT and critical white studies is the interview in which participants narrate stories about their histories and experiences. The narrative, also called storytelling or counter storytelling, is considered a suitable methodological choice for the researcher because it gives voice to those who have historically been marginalized. An illustration of this style is Harushimana’s (2010) essay describing the author’s journey as a third language learner of English in Africa and subsequently as a graduate student of English in the USA and finally as a professor.

Border crossing between composition studies and general writing in SLA is emphasized in Cox et al. (2010), a book that explores issues of identity in SLA writing. According to the authors, composition studies dominate this field because composition courses, introduced in American universities in the late nineteenth century, are still a requirement for all undergraduate students in all disciplines. In addition to the large volume of students who take composition courses, a substantial percentage of these students are studying English as a second language. Though the way students express their identity through their compositions has always been of importance to scholars, the emphasis has now shifted to the nuances of “becoming” rather than “being.” In other words, scholars see students’ identities are constantly shifting and being formed and transformed by their writing, including their compositions. What the authors mean is that identity cannot be essentialized into neat categories as it is an attribute that is constantly in flux.

Both Creese et al. (2006) and Li and Zhu (2013) took an ethnographic approach to exploring issues of identity within diasporic groups. Creese, Bhatt, Bhojani, and Martin analyzed the identity of Gujarati children in London studying in complementary schools. They found that Gujarati students in two specific neighborhoods in London displayed heritage and learner identities encouraged by the school. However, in contrast to these, the children also developed multicultural identities that were fostered not only by the school but also by the environment in which they lived. They suggested that “society does not have clearly demarcated traditions that blend into distinct heritages. Rather, there is a co-existence of many heritages and newly invented traditions within a single nation-state” (p. 36). Thus the authors emphasize the identity cannot be essentialized into one identity and one language. In their data they find that the Gujarati students and teachers have moved from India to East Africa to the UK, and in this journey their identities have shifted and transformed. Thus complementary schools do not emphasize “essentialized ethnic or heritage identities but instead provide a context for students to combine their different life experiences in more fluid ethnicities with flexible bilingualism” (p. 41).

Li and Zhu (2013) took a similar approach to researching identity among Chinese university students in the UK. Using the conceptual hook of translanguaging, the authors conducted a “moment analysis” of the way five young Chinese men interact with each other. As Li and Zhu explained, “moment analysis was proposed in the

context of studying multilingual creativity in everyday social interaction” (p. 522). The emphasis on moment analysis is on “spur-of-the-moment creative actions that have both immediate and long-term actions” (p. 522). Through an analysis of interactional data, they find that students of Chinese origin in the UK universities display creativity during translanguaging practices and perform identity. Thus translanguaging is not merely the mixing of languages in utterances but a celebration of identity. Li and Zhu’s use of translanguaging and moment analysis to coding their transcripts adds a new dimension to the way ethnographic data in field of identity and SLA can be analyzed.

---

## Work in Progress

Work in progress in the field of SLA and identity is shifting the location of language learning from inner circle countries to outer circle countries. This has enormous implications for transnational identities in diasporic communities. For instance, Kang (2012) explored language use and identity in a Korean community in Singapore. South Koreans, who have migrated to Singapore to avail of the English-medium national school system, form a substantial community. This community has chosen to learn English in an outer circle country that also offers instruction in Mandarin, considered to be a language of great instrumental and professional value in the twenty-first century. Along with English and Mandarin, the South Korean students also pick up Singlish, which is a colloquial variety of English spoken in Singapore. Rather than mapping one language onto one language ideology, Kang argued for a “metapragmatic discourse of language” through which South Koreans display a global Asian identity. They value English most for its instrumental value and Mandarin for the value it would have in future. These languages give the diasporic Korean community a global Asian identity. However, the young students also value Singlish because it helps them make friends. Thus these three languages together, spoken with sociolinguistic competence, give the diasporic Korean community both locality and solidarity. Kang further contended that learning English in an outer circle country implies a challenge to the hegemony of Western modernity. Singapore is uniquely positioned as a first world country in Asia that offers textbooks, pedagogies, and curricula based on inner circle countries but delivered by local teachers. The outcome of this language learning experience is thus different from, for example, Japanese students going to the USA to learn English where the native speakerism is reinforced.

A group of students that has been less researched is that of L2 writers in secondary school. When the topic is second language writing, most data sets are regarding college students. According to Ortmeier-Hooper and Enright (2011), this is the growth area in the field of identity and SLA as this cohort of secondary school students has been under-researched. Though there are about five million such students in secondary schools in the USA, only about 3% of research is on this cohort specifically. In their introductory article to a special issue on *Adolescent L2 Writers in US Contexts*, Ortmeier-Hooper and Enright offered a conceptual model

with three foci regarding research on L2 writers: identity negotiation/social interaction, national policy and curricula, and students' postsecondary trajectories. It is the first research focus that concerns us here. Adolescents are at a stage in life when they are negotiating affiliations, identities, and career paths, all of which affect their choices and attitudes to L2 writing. According to Ortmeier-Hooper and Enright, "any understanding of adolescent L2 writers must begin with the acknowledgement that identity negotiation and social interaction. . .are significant to discussions about how these teenage students respond to their writing tasks. . ." (p. 171). A key feature of the way teenagers negotiate identity is resistance and acceptance: for instance in some cases they resist the label of being L2 learners and at time they embrace this moniker. Also the kind of writing that adolescents enjoy of school through the medium of technology, a platform where adolescents celebrate identity, determines their motivation and attitude toward writing tasks prescribed at school.

---

## Problems and Difficulties

The social turn taken by scholars in SLA research has now become deeply entrenched in the field. According to Block (2003) until the mid-1990s, calls for a socially informed interdisciplinary approach to SLA were notable by their absence. Citing the special issue of *Modern Language Journal* published in 1997, Block comments that the late 1990s saw a shift in trends regarding research in SLA. The shift was from a more psycholinguistic and cognitive approach to language learning toward a more social and interactionist approach. Though this shift is now firmly ingrained in SLA, it has thrown up some new conundrums that scholars need to grapple with. I will focus on two main issues: the first is the definition of "second language" and the second is the role of technology in language learning.

In the twenty-first century which is defined by the global flows of people, media, and currencies, nations and individuals are reorienting themselves to linguistic affiliations. Monikers like "national language," "second language," and "mother tongue" are not applicable across the board as groups of people move across national boundaries and reinvent their identities. A case in point is Singapore, one of the most globalized countries in the world. To ascribe a "second language" to children in Singapore is difficult as many children grow up in a highly bilingual linguistic ecology where they acquire two first languages. Also, the L1 and L2 could change as these children transition through 12 years of schooling: what was their L2 could become their L1 by the time they complete high school.

Technology has changed the access that learners have to language. When Bonny Norton published her seminal work, *Identity and Language Learning*, technology was not a major issue impacting the language learning of the five immigrant cases in her study. One of the problems faced by the women in Norton's study was that because they were in a powerless social position, they had limited access to opportunities for conversations with speakers of the target language. Though there is no substitute for face-to-face interaction, today's environment provides many more opportunities for the learner to listen to the target language and use it. At the



same time, the challenge is for teachers to adopt best practices using technology that enhance the listening, speaking, reading, and writing of L2 learners.

---

## Future Directions

Within the field of identity and SLA, two themes emerge that likely will dominate future studies in this area: the labeling of students and the impact of World Englishes on SLA. Nero (2005) found that “the ‘native/non-native’ dichotomy, by assigning. . . fixed linguistic identities to students, often missed the mark, for many. . . students claimed simultaneous types and levels of relationships with different languages and language groups” (p. 195). The problem in most ESL classes in the USA, according to Nero, is that though these classes celebrate diversity in theory, they are actually platforms for assimilation. Students are expected to assimilate into American ways of speaking, writing, and living, which is the underlying goal of SLA. However, what Nero found was that students resist both the label of “ESL” identity and the assimilationist ideology.

This finding reinforced Rampton’s view (1990) that students resist being docketed into categories because their language experiences are not only varied but their identities keep changing in a cultural space. Rampton observed that instead of limiting terms like “mother tongue” and “native speaker,” it is more constructive to look at the language expertise, affiliation, and inheritance of learners. Expertise has to do with the proficiency with which a language is learned; a native speaker could have less expertise than a nonnative speaker. Affiliations emerge as people negotiate identities; a student could have a closer affiliation with his/her second language compared with his/her mother tongue. Finally there is inheritance, which also means heritage, and consists of what speakers inherits from their families and geographical location. Rampton’s view is that expertise, affiliations, and inheritance coexist in shifting forms to give speakers their identities.

As a way forward, Nero (2005) recommended the use of an instrument called Language Identity, Awareness, and Development (LIAD). This instrument does not essentialize students into labels like ESL or ELL; rather, it gives students the opportunity to show their affiliations with various languages and also show how these affiliations have changed over the years. Nero offered samples of answered student questionnaires in the series of appendices. The tabulated results showed that out of a total of 61 students in the MA-TESOL program at St John’s University (Fall 2000 to Spring 2003), 47 were born in the USA. Of these 47, 43 claimed English as their native language, yet they were in a MA-TESOL program with other students who were born outside the USA and did not speak English as a native language. This instrument clearly exposes problems with labels like ESL, ELL, native, and nonnative.

The problem, according to Rampton (1990), is that people think of the native speaker as one who has one mother tongue and of this speaker as the best representative of speech and writing in that language. However, nativeness is not synonymous with best practice in language, as Nero’s research has demonstrated.

“Expertise” is learned and not inherited. It is also not innate and a nonnative speaker can have more expertise than a native speaker. Thus the idea of expertise shifts the focus from “who you are” to “what you know” which is a more objective criteria for evaluating teacher and students of language. Language expertise cannot be dissociated from language loyalty that includes both inheritance and affiliation. Inheritance occurs within social boundaries and can consist of a group of white native speakers of English. However, affiliation occurs across social boundaries and can consist of a group of English teachers from all parts of the world including their diverse students learning English as a second language.

---

## Conclusion

The era of globalization in which we live has surfaced issues of language affiliation and identity which are unprecedented. Though discussions of identity reflect the complex nature of the world in which we live, the field of SLA needs to be more cognizant of this complexity. Let us take Singapore, where I am writing this paper, as an example. The very term “second language” is controversial in a country like Singapore. Language learners in Singapore’s schools could study their “mother tongue” as a second language, and by the time they finish 12 years of English-medium schooling, their affiliation, expertise, and inheritance of and with English could be stronger than that with their “mother tongue.” For many bilinguals in Singapore, exactly what is their first and second language is not very clear. Thus in today’s context, the very term “second language” needs to be reworked because not every bilingual learns languages in neat order one after the other.

---

## Cross-References

- ▶ [Language Teacher Research Methods](#)
- ▶ [Researching Identity in Language and Education](#)

---

## Related Articles in the Encyclopedia of Language and Education

Jasmine Luk Ching Man: [Classroom Discourse and the Construction of Learner and Teacher Identities](#). In Volume: *Discourse and Education*

---

## References

- Block, D. (2003). *The social turn in second language acquisition*. Edinburg: Edinburg University Press.
- Canagarajah, A. S. (1993). Critical ethnography of a Sri Lankan classroom: Ambiguities in student opposition to reproduction through ESOL. *TESOL Quarterly*, 27(4), 601–625.

- Cox, M., Jordan, J., Ortmeier-Hooper, C., & Schwartz, G. G. (Eds.). (2010). *Reinventing identities in second language writing*. Urbana: NCTE.
- Creese, A., Bhatt, A., Bhojani, N., & Martin, P. (2006). Multicultural, heritage and learner identities in complementary schools. *Language and Education, 20*(1), 23–43.
- Downes, S. (2001). Sense of Japanese cultural identity within an English partial immersion programme: Should parents worry? *International Journal of Bilingual Education and Bilingualism, 4*(3), 165–180.
- Harushimana, I. (2010). Blinding audacity: The narrative of a French-speaking African teaching English in the United States. In M. Cox, J. Jordan, C. Ortmeier-Hooper, & G. G. Schwartz (Eds.), *Reinventing identities in second language writing* (pp. 232–240). Urbana: NCTE.
- Kang, Y. (2012). Singlish or Globish: Multiple language ideologies and global identities in Korean educational migrants in Singapore. *Journal of Sociolinguistics, 16*(2), 165–183.
- Kubota, R., & Lin, A. (Eds.). (2009). *Race, culture, and identities in second language education: Exploring critically engaged practice*. London: Routledge.
- Lambert, W. E., & Tucker, G. R. (1972). *Bilingual education of children: The St. Lambert experiment*. Rowley: Newbury House.
- LePage, R., & Tabouret-Keller, A. (1985). *Acts of identity: Creole-based approaches to language and ethnicity*. Cambridge: Cambridge University Press.
- Li, W., & Zhu, H. (2013). Translanguaging identities and ideologies: Creating transnational space through flexible multilingual practices amongst Chinese University students in the UK. *Applied Linguistics, 34*(5), 516–535.
- Liu, P.-H. E., & Tannacito, D. J. (2013). Resistance by L2 writers: The role of racial and language ideology in imagined community and identity investment. *Journal of Second Language Writing, 22*, 355–373.
- Martin-Jones, M., & Heller, M. (1996). Introduction to the special issue on education in multilingual settings: Discourse, identities, and power. *Linguistics and Education, 8*, 3–16.
- Nero, S. J. (2005). Language, identities, and ESL pedagogy. *Language and Education, 19*(3), 194–211.
- Norton, B. (1995). Social identity, investment, and language learning. *TESOL Quarterly, 29*(1), 9–31.
- Norton, B. (2000). *Identity and language learning: Gender, ethnicity and educational change*. London: Longman.
- Ortmeier-Hooper, C., & Enright, K. A. (2011). Mapping new territory: Toward an understanding of L2 writers and writing in US contexts. *Journal of Second Language Writing, 20*, 167–181.
- Pierce, B. N. (1995). Social identity, investment, and language learning. *TESOL Quarterly, 29*(1), 9–31.
- Rampton, B. (1990). Displacing the “native-speaker”: Expertise, affiliation and inheritance. *ELT Journal, 42*(2), 97–101.
- Sarangi, S., & Baynham, M. (1996). Discursive construction of educational identities: Affirmative readings. *Language and Education, 10*(2/3), 77–81.

---

**Part III**

**Language, Culture, Discourse,  
and Education**

---

# Ethnography and Language Education

Ariana Mangual Figueroa

---

## Abstract

This chapter traces historical and contemporary approaches to conducting ethnographic research on language education. Mangual Figueroa highlights key theoretical concepts and methodological approaches central to the field, focusing on the potential for ethnographic research to inform socially responsible and democratically minded practices in schools and communities. The chapter focuses largely on research conducted in North American contexts, paying close attention to the contributions of the Ethnography of Speaking approach and Linguistic Anthropology. It covers new terrain in global and multi-sited ethnographic work conducted in diasporic communities in the United States while also examining the complex methodological issues that can arise in the field. The chapter closes by discussing recent, ongoing ethnographic research concerned with tracking the influences of power on language and learning with the goal of advocating for racial and economic equality for all language learners.

---

## Keywords

Ethnography • Methodology • Multi-sited • Ethics • Power

---

A. Mangual Figueroa (✉)

Graduate School of Education, Rutgers University, New Brunswick, NJ, USA

e-mail: [amf@gse.rutgers.edu](mailto:amf@gse.rutgers.edu)

## Contents

Introduction .....	270
Early Developments .....	270
Major Contributions .....	272
Ethnography of Speaking .....	272
Linguistic Anthropology of Education .....	274
Works in Progress .....	275
Problems and Difficulties .....	276
Future Directions .....	278
Cross-References .....	279
Related Articles in the Encyclopedia of Language and Education .....	279
References .....	280

## Introduction

In the influential 1987 volume edited by George and Louise Spindler, educational anthropologist Harry F. Wolcott asserted that “the purpose of ethnographic research is to describe and interpret cultural behavior” (p. 43). Conducting ethnographic research involves integrating a rich theoretical understanding of culture with the systematic documentation and analysis of a set of social practices. More recently, Shirley Brice Heath and Brian Street pointed out that the unique job of an ethnographer studying language and literacy is to sort “out as many connections of language and culture as possible across recurring and definable situations” (2008, p. 11). Ethnographers of language education seek to document patterns within everyday interactions in order to examine the organizing principles that guide teaching and learning across contexts. As we will see, ethnographers of language education share a commitment to studying language and social processes with the goal of making educational opportunities accessible and equitable for all.

## Early Developments

Anthropological research conducted during the first half of the twentieth century laid the foundation for enduring perspectives on language and ethnography. A brief look at the work of Franz Boas, Edward Sapir, and Benjamin Whorf provides an orientation to key terms and techniques echoed in the following sections of this chapter. It is noteworthy that Boas was Sapir’s teacher and that he, in turn, trained Whorf in the field of anthropological linguistics; the processes of teaching and learning that we study as educational anthropologists of language are exemplified in the development of the field itself. While other ethnographers have made significant methodological contributions, I focus on the work of these three male ethnographers from Europe and the United States working with Native American communities in North America because of the foundational contributions they made to the study of language.

Responding to theories of cultural determinism prevalent at the time, Boas – founder of the first department of anthropology in North America – argued that

linguistic and cultural behavior is not determined by race. His *Handbook of American Indian Languages*, published in 1911, demonstrated that although the rules of language use are often tacit and unexplainable by its speakers, it does not follow that those rules and accompanying behavior are the result of a speaker's racial characteristics (attributes considered to be largely biological during Boas' time). After conducting a systematic review of cases of racial mixing and language shift around the world and throughout history, Boas concluded that "anatomical type, language, and culture have not necessarily the same fates" (p. 13). He argued that ethnographers should speak the languages of the groups that they research in order to move beyond the external analysis of linguistic structure toward the study of speakers' behavior and interaction within a social group.

Through his study of the Yana language and its speakers in California, Sapir worked to further define language and culture. In a series of essays, he argued that language served two main functions: first, a communicative function, inherent in its "formal completeness" which granted speakers the phonetic and referential material needed for expression (1968/1924, p. 153), and second, a socializing function, which led to "social solidarity" among speakers of a particular language (1968/1933, p. 15). Sapir found that the underlying rules that guided language use were highly patterned and, as Boas (1911) had asserted, often tacit to speakers of that language. As a result, he argued that the ethnographer could gain the most insight into language use and culture by observing breaks in these patterns. In order to observe these subtle events and ascertain their significance for members of a cultural group, the ethnographer needed to engage in close and sustained observation of social behavior.

Informed by Boas' position on determinism and Sapir's focus on the relationship between the individual speaker and social group, Whorf conducted a comparative study of the concepts of space and time in Hopi and Standard American English. He argued that the distinct grammatical systems reflected a different concept of temporality that in turn reified the speakers' definition of and relationship to time. Whorf extended Sapir's notion of language as an unconscious system, concluding that members of a speech community not only adhere to the tacit rules of their language but also adopt the worldview embedded within that language. He called this worldview a "fashion of speaking" – a way of perceiving the world that is informed by grammatical structures that shape the cultural frame of reference shared by speakers of a language (1995/1941, p. 83). Whorf advocated a comparative study of language that could bring into relief the differences between the ethnographer's and participants' language in order to identify those linguistic and cultural features that are unique or shared across cultures.

These works constitute important early developments in the ethnography of language education not because they are conclusive, but because they are indicative of the kinds of inquiry that continue to guide the field. In fact, much of the research covered in the next section of this review turned away from the more structural views of language elaborated by Boas, Sapir, and Whorf. The shift away from structuralism – the view that culture and ideology exists in language prior to social interaction – toward theories that situate language squarely in social context is all the more significant given the essential concepts and approaches that endured despite the

turn. Language education researchers continue to explore concerns taken up in this early period, including the role of language in society, the relationship between race and language, and the significance of language, learning, and socialization, among others. Moreover, methodological principles considered innovative during this early period are now taken for granted. For example, ethnographers of language document and analyze everyday routines, they often take a comparative approach to the study of language and its use, they seek patterns and anomalies in behavior, and they observe interaction and ask probing questions that elicit speakers' metalinguistic awareness.

---

## Major Contributions

Ethnographers of language education have various research interests (evident in the diverse demographic groups and social experiences studied) and set forth a range of goals (from theory building to enacting social change). Kelleen Toohey's (2008) chapter on "Ethnography and Language Education" in the previous edition of this volume provides an in-depth review organized by central concerns in the field of language education – topics such as identity, home-school relationships, and cultural resources. Here I focus on two main approaches to ethnographic research employed in the field – first, the Ethnography of Speaking, and second, Linguistic Anthropology. Both of these exemplify the integration of theory and methodology outlined by early educational anthropologists and maintained by ethnographers today. I cite significant contributions from the field of Language Socialization, but I will not cover it as a separate approach since it will be reviewed in depth in Paul Garrett's contribution to this volume.

## Ethnography of Speaking

In his 1964 essay, *Toward Ethnographies of Communication*, Dell Hymes quoted Sapir's call for linguists to "become increasingly aware of the significance of their subject in the general field of science" by conducting language research informed by and relevant to a broad set of social concerns (p. 1). Hymes was writing at a moment in which the field of linguistics was being developed according to prevalent Chomskyan approaches to descriptive grammatical study based upon idealized notions of the speaker/hearer. He was also writing in the wake of the "culture of poverty" concept, introduced in 1961 by anthropologist Oscar Lewis to explain his observations of life in a poor community in Mexico City. Against this backdrop, Hymes called upon language researchers to explore enduring questions regarding the role of language in society and the efficacy of deterministic theories of culture. These questions gained particular importance in the field of education because of the role schools play in the assessment and instruction of students in multilingual and multicultural settings shaped by integration and immigration (Gándara and Contreras 2010).



Dell Hymes and John Gumperz collaborated on many of the programmatic statements outlining this “speaker-oriented approach to conversation” (1964; Gumperz 1982, p. 35); these essays are themselves reviews of the emerging field of language education. In them, Hymes and Gumperz extended previous theories of language use and linguistic structure. They moved, for example, away from Sapir’s comparisons of bounded language systems that he assigned to speech communities presumed to be culturally homogeneous toward the concept of “verbal repertoires” that highlighted the dynamic and diverse communicative resources employed by interlocutors. They also shifted away from Whorf’s assertions that linguistic and ideological complexity was encoded in internal patterns within the linguistic system to the concept of “communicative events” that placed talk and social interaction at the center of research on language and culture. Along with other ethnographers working at the time, Hymes and Gumperz worked to capture the emergent quality of a rapidly changing social context that was empirically observable by tracking the “contextualization cues” employed by speakers in real-time interactions (Gumperz 1992, p. 232).

Two key methodological tenets for the ethnographic study of language were elaborated upon during this period (see Wortham 2003, for a related but different framing of these approaches). The first tenet was to seek local understandings of language in context. Hymes believed that our ethnographic imperative was to move from an “etic grid to discover an emic system” (1964, p. 24). From this perspective, ethnographers are thought to enter the field with beliefs about language and its speakers, and their work is to test those preconceptions or hypotheses against the everyday communicative practices of a community. According to Hymes, these practices are documented and analyzed by attending to the shifting and patterned roles that interlocutors take up in relation to one another and the multiple functions that language plays in the course of interaction. This is essential to understanding the ways in which communicative competence is defined, imparted, and demonstrated within a social setting. Ethnographers of language working across the globe have taken up the concept of communicative competence in order to examine their own methodological approaches to fieldwork as well as the cultural practices of the communities they study (see Ochs 1979; Moore 2009).

The second methodological principle was that interactions between diverse speakers in public institutions are points of contact that offer ethnographers unique opportunities to study the social significance of language use in a multicultural society. Displays and evaluations of communicative competence are never neutral – this is particularly true in the field of language education because school evaluations of speaker competence often have ideological and material consequences for those students and families being evaluated (García Sánchez 2014). As Hymes explained, researchers in language education are often “assuming from the outset a confrontation of different systems of competency within the school and community, and focusing on the way in which one affects or can be made to affect the other” (1972, p. 68). This is an enduring focus in the ethnography of language education as scholars have documented those tacit assumptions about language use and competency that guide interaction across settings, the continuities and disconnects that exist

across cultural frames of reference, and the impact of school-based assessments on the lived experiences of speakers and communities (see Erickson 1984; Baquedano-López et al. 2013 for critical reviews of this enduring concern). Hymes believed that raising these questions in schools and with practitioners was essential for addressing issues of equity and social justice that were fundamental if schools were to fulfill their democratic potential (see *Anthropology & Education Quarterly* special issue dedicated to Dell Hymes).

## Linguistic Anthropology of Education

In a 2003 essay, Stanton Wortham established a bidirectional relationship between the ethnography of speaking outlined above and the linguistic anthropology of education. The common theoretical and methodological approaches used in these two fields have led to a contemporary focus on communicative competence, emic perspectives on language use, and macro-micro connections evident in interaction. Wortham argued that linguistic anthropologists today are largely concerned with four topics related to the social context of language use – indexicality, creativity, regimentation, and poetic structure – and that schools and educational settings are ideal places to engage in the study of these phenomena. As Betsy Rymes (2003) has noted, linguistic anthropology in education has extended our study of language to include a range of semiotic processes that are not limited – though often related – to speaking. Very often, she observed, the ethnographic study of semiotic processes has taken place in out-of-school educational settings, while studies of speaking have focused on teaching and learning activities conducted in schools and classrooms.

It is important to highlight two contributions made by linguistic anthropologists that have extended our theoretical understanding of and methodological approaches to the study of language education. The first is the focus on language as constitutive – not merely reflective – of social context; the second is the concept of a repertoire of semiotic resources that interlocutors employ during the course of an exchange. The related concepts of indexicality and creativity draw our attention to the agentic ways in which interlocutors use language to communicate desired meanings as well as the multiple ways in which these messages can be interpreted (Ochs 1996; Wortham 2003). These messages and their interpretations have social consequences that offer clues about the social context to interlocutors and ethnographers alike and that also help to produce the context in which subsequent interactions unfold. While context can be contingent and emergent, it is also bound by certain conventions such as language ideology and poetic structure (Wortham 2003). These theoretical principles, coupled with conversation analytic tools for analyzing language, mean that linguistic anthropologists continue to seek emic points of view by taking inductive approaches to data analysis and systematically analyzing “*patterns of semiotic cues* across particular segments of language use, instead of relying on isolated instances selected from the data” (Wortham 2001, emphasis in original, p. 257).

Focusing on creativity and communicative resources highlights the individual’s use of a range of semiotic material – refocusing our attention away from community-

level generalizations about language use and toward the particular insights that individual language use can give us into local social norms. Rymes' (2010) concept of the communicative repertoire builds on the verbal repertoire introduced by Gumperz in an attempt to reconcile the relationship between the individual and the community and the macro and the micro connection in language use. As in the ethnography of speaking tradition, one of the goals of the linguistic anthropology of education is to raise the metalinguistic awareness of educators and students, to enlist them in the research process, and to employ current technological tools to democratize the ethnographic approach (Rymes 2010). Ana Celia Zentella's (1997) book *Growing Up Bilingual* is an important example of democratizing research through, what she calls, an *anthropolitical* linguistic approach drawing from linguistic anthropological and sociolinguistic traditions. The goal of this approach is to simultaneously "understand and facilitate a stigmatized group's attempts to construct a positive self" in the context of macroeconomic and social systems that stigmatize groups of people and their language (Zentella 1997, p. 13; see also González 2006).

---

## Works in Progress

Educational ethnographers who study language are taking up multi-sited and global ethnographic approaches as they work to amplify their methodology in keeping with rapidly changing social settings. In a recent essay, Voussoughi and Gutiérrez (2014) call for the development of a "multi-sited sensibility" that can contribute to our understanding of "learning as the organization of possible futures" (p. 609). They argue that scholars concerned with educational equity and ethnographic rigor can take up multi-sited approaches that capture the complexity of the everyday practices of communities living in contexts of migration. By studying the movement and enactment of culture and literacy across sites, we can work against the tendency to essentialize and homogenize nondominant communities and highlight the humanizing and democratizing potential of communities and our work within them (Voussoughi and Gutiérrez 2014). Multi-sited and global approaches are particularly well suited for ethnographers of language education because of the close attention to language and discourse suggested in the early statements delineating these methods.

In a description of multi-sited ethnographic research, Marcus (1995) explained that it "is designed around chains, paths, threads, conjunctions, or juxtapositions of locations in which the ethnographer establishes some form of literal, physical presence, with an explicit, posited logic of association or connection among sites" (p. 105). For Marcus, shifting from studying cultural practice in a single site toward studying people's everyday lives across multiple sites requires interdisciplinary study and a fundamental redefinition of ethnography. Marcus claimed that in order to track social and cultural phenomena across sites, the ethnographer must be able to understand discourse and "cultural idiom" as it travels, with the goal of making "connections through translations and tracings among distinctive discourses from site to site" (1995, pp. 100–101). This complements Buroway's (1991) call for ethnographers working in a global paradigm to engage in "dialogue" with

participants, acknowledging the role of power in shaping these interactions and using grounded theory approaches to reexamine and revise existing social theory. Both Marcus and Buroway have suggested that as ethnographers engage in participant observation, they may become activists as well – implicated in the everyday practices that they study and compelled to act in ways that establish ever deepening connecting with the communities they work alongside. Early methodological principles are echoed in these statements – dating back to Boasian claims that ethnographers should speak the languages (broadly defined in contemporary formulations) of the communities that they study and Whorfian calls for ethnographers to conduct comparative work across sites.

Several examples of multi-sited ethnographic research in the field of language and literacy exemplify the potential of the method for producing insights into routine interactions and for capturing emerging social practices. Lam's (2004) multi-sited study of interactions among members of a Chinese/English speaking peer group in face-to-face school interactions and virtual online forums demonstrated the ways in which language socialization is both informed by and also potentially subversive of state-defined national boundaries. The multiple sites for multilingual exchange suggest the possibility of the creation of new registers and codes that index emerging identities in a global context. Pahl's (2007) reflection on her 3-year multi-sited study of a family living in a Turkish Diaspora in London offered insight into the ways in which close attention to language use and literacy practices allowed her to see the various influences – intergenerational, international, and economic – on children's developing modes of communication and frames of reference. Emerging research from UC Berkeley's Laboratory for the Study of Interaction and Discourse in Educational Research (L-SIDER) led by Patricia Baquedano-López demonstrates the interdisciplinary and collaborative nature of multi-sited ethnographic work in the field of language socialization and education. This work includes research on Latina mothers advocating for their children's educational needs in community and institutional settings (Domínguez-Pareto 2014) and multi-sited ethnographic studies of the ways in which family members take up institutional discourses of educational reform within home settings (Hernandez 2013). Readers are also directed to two reviews of multi-sited ethnographic work in education that lay an important foundation for continued work in this area: Eisenhart's (2001) essay including a description of multi-sited approaches within educational ethnography and Hornberger's (2007) exploration of multi-sited studies specifically focused on transnationalism and language learning.

---

## Problems and Difficulties

As ethnographers have worked to reconceptualize the boundaries of the traditional field site, they have also redefined the role of the ethnographer. Such shifts include a move away from the image of the neutral participant toward the belief that the ethnographer's presence inevitably changes those social processes that she observes

(Duranti 1997). Researchers have highlighted the emergent nature of qualitative research, suggesting that ethnographers need not only document dynamic social processes but also be prepared to adapt their methodological approaches based upon unanticipated conditions and experiences encountered in the field (Howe and Dougherty 1993). In this framework, a unique set of ethical challenges emerges; I briefly review three of them here: reciprocity and the writing process, language use, and entering/exiting the field.

Reciprocity has become a central ethical principle that guides ethnographers considering ways of equalizing the exchange between themselves and those who agree to participate in their studies. In volume six of the *Ethnographer's Toolkit* (1999), LeCompte, Schensul, Weeks, and Singer conceived of reciprocity as the act of “sharing ideas, resources, and responsibilities” (p. 65). Hernandez (2013) suggests that ethnographers should share not only social and material capital but also what she calls “the analytic gaze.” She argued that examining and publishing moments of researcher vulnerability would equalize the scrutiny placed on participants and ethnographers alike.

Ethnographers of language are particularly sensitive to their own language use and are reflective about the tools that they use to record participants' interactions. As mentioned briefly above, linguistic anthropologists and language socialization researchers have examined the ways in which their fluency in the language of the communities they study simultaneously shapes their ability to collect locally relevant data and interpret it with emic lenses (Moore 2009). In the field of language socialization, children are considered central social actors in any interaction and, as a result, unique modes of data collection and representation are needed to reflect the multiple communicative resources (not always verbal) that they employ in interaction (Ochs 1979). In addition, audio and visual tools for recording interaction may run the risk of reproducing participants' marginal identities or may be appropriated by participants to assert novel and agential forms of self within the study (Martinez 2016).

Ethnographers in the field of anthropology and education have raised a series of ethical concerns related to two aspects of the data collection process – obtaining informed consent at the outset of the study and concluding a study by exiting the field. By examining the institutional review board and informed consent process in which researchers apply for institutional approval of their study and then obtain participant agreement to participate, anthropologists have highlighted that these linguistic and legal processes shape our relationships to participants and can impact our roles throughout the study (Metro 2014). This initial stage of the research process tends to focus on protecting research institutions and the researcher from liability in the field, but it can also become an opportunity for us to consider how forms of reciprocity and responsibility might become integral to the research design and process (Mangual Figueroa 2016). In addition to focusing on ethical issues raised at the start of data collection, I have also argued that attending to the moment of exiting the field is an overlooked yet essential part of our work. As we attempt to conclude our research and exit the field, participants may ask us to reciprocate their

participation in our studies in ways that that we could not have anticipated before they had gotten to know us during the ethnographic process. The concept of a spatially and temporally delimited field that a researcher enters and exits might itself need to be reconceived in an era of globalization in which we are implicated in those economic, social, and political systems that shape our participants' lives directly or indirectly (Mangual Figueroa 2014).

---

## Future Directions

Ethnographers of language education – including those that feature language itself as the central unit of analysis and those that center language learners as their focal participants – are concerned with the ways in which their research can make meaningful, positive change in the educational experiences of the communities and youth that they study. As federal regulations and funding sources continue to shape educational research by delineating what counts as valid research and what areas of study should be supported, educational researchers are calling for a definition of scholarly rigor that includes the criterion of “relevance” (Gutiérrez and Punuel 2014). In this formulation, rigor is not defined solely by criteria internal to the research design and analysis of data but also in relation to the study's import for the individuals and communities involved in the research process. I will briefly suggest two areas that ethnographers of language education may consider when making their research relevant to learners living in a diverse and dynamic society.

In a recent essay, Paris and Alim (2014) reviewed over five decades of educational research focused on honoring and preserving the linguistic and cultural heritages of communities of color in US schools. The goal of this review was to build upon previous educational research – much of it ethnographic – in order to elaborate a new paradigm for democratizing and humanizing future research. They asserted that in order to take on enduring challenges in our field – ones that arguably date back to some of the early anthropological work reviewed in this chapter – scholars must work against racial and linguistic deficit models, conceptualize equity not as cultural assimilation but instead as cultural sustainability, and resist oversimplistic views of racial identity that correspond to a stereotypic and static set of social practices. In order to work toward the “culturally sustaining pedagogy” that they call for, Paris and Alim ask that we consider research methodologies and educational practices that can support “the many practices and traditions of communities of color that forward equity” (p. 95). This includes not only foregrounding the positive and productive forms of cultural production that youth engage in but also critically examining the ways in which these practices may reproduce or create new injustices and marginalities. In this reflexive project, ethnographers of language education can work alongside communities of color to advocate social justice for all.

In 1972 anthropologist Laura Nader published an article entitled *Up the Anthropologist – Perspectives Gained from Studying Up*. She argued that “‘Studying up’ as

well as down would lead us to ask many ‘common sense’ questions in reverse. Instead of asking why some people are poor we would ask why other people are so affluent?” (p. 289). Nader literally turned the ethnographers’ work on its head – suggesting that in order to understand the way that power is produced, exerted, and preserved, we must study those individuals, communities, and institutions that wield it. Moreover she claimed that this kind of research can contribute to a better understanding of the everyday lives of those historically marginalized communities that anthropologists tend to study. More recently, Hamman (2003) applied the concept of studying up to educational anthropology, arguing that this approach can help to engage in a form of scientific research based upon the premise that educational research, policy, and practice is inherently political. This view, he argued, would allow us to challenge research findings that profess to be neutral and objective while also having disproportionate consequences for racialized and impoverished communities and their children. This ethnographic approach is exemplified in López’s (2012) longitudinal study of the ways in which the Texas state legislature developed the state’s testing and accountability regime, Wayne Yang’s (2010, published under the name Paperson) examination of the mechanisms used by school board officials in one California city to disenfranchise community members and close a neighborhood school, and Lipman’s (2011) study of the pervasive effects of neoliberal policies in the educational, economic, and civic lives of Chicago residents. These scholars redefine the role of the participant observer – they are educational advocates, school leaders, and scholar-activists as well as researchers, and they are unapologetic about conducting research that documents power and inequity while simultaneously demanding social justice. Moreover, they consider the multiple forms that scholarly research might take and the multiple audiences it might reach; by disseminating scholarly articles, public speeches, political pamphlets, and more, these researchers work to support communities working to meet the exigent educational needs that they face.

---

## Cross-References

- ▶ [Critical Ethnography](#)
- ▶ [Linguistic Ethnography](#)
- ▶ [Microethnography in the Classroom](#)
- ▶ [Researching Language Socialization](#)
- ▶ [Researching the Language of Race and Racism in Education](#)
- ▶ [Researching Timescales in Language and Education](#)

---

## Related Articles in the Encyclopedia of Language and Education

[Encyclopedia of Language and Education, Language Socialization](#) (whole Vol. 8)

## References

- Baquedano-López, P., Alexander, R. A., & Hernandez, S. J. (2013). Equity issues in parental and community involvement in schools: What teacher educators need to know. *Review of Research in Education, 37*(1), 161–194.
- Boas, F. (1995 [1911]). Introduction to the handbook of American Indian languages. In B. Blount (Ed.), *Language, culture, and society: A book of readings* (pp. 9–29). Illinois: Waveland Press, Inc.
- Burroway, M. (1991). Introduction. In M. Burroway, A. Burton, A. A. Ferguson, K. J. Fox, J. Gamso, N. Gartrel, L. Hurst, C. Kurzman, L. Salzinger, J. Schiffman, & S. Ui (Eds.), *Ethnography unbound: Power and resistance in the modern metropolis* (pp. 1–7). California: University of California Press.
- Domínguez-Pareto, I. (2014). *Learning advocacy: Decentering parental involvement discourse through the experiences of Latina mothers of children with disabilities in northern California*. Doctoral dissertation, University of California, Berkeley.
- Duranti, A. (1997). *Linguistic anthropology: A reader*. Cambridge: Cambridge University Press.
- Eisenhart, M. (2001). Educational ethnography, past, present, and future: Ideas to think with. *Educational Researcher, 30*(8), 16–27.
- Erickson, F. (1984). School literacy, reasoning, and civility: An anthropologist's perspective. *Review of Educational Research, 54*(4), 525–546.
- Gándara, P., & Contreras, F. (2010). *The Latino education crisis: The consequences of failed social policies*. Massachusetts: Harvard University Press.
- García Sánchez, I. (2014). *Language and Muslim immigrant childhoods: The politics of belonging*. New York: Wiley Blackwell.
- González, N. (2006). *I am my language: Discourses of women and children in the borderlands*. Arizona: The University of Arizona Press.
- Gumperz, J. J. (1982). The sociolinguistics of personal communication. In J. J. Gumperz (Ed.), *Discourse strategies* (pp. 9–37). Cambridge: Cambridge University Press.
- Gumperz, J. J. (1992). Contextualization and understanding. In A. Duranti & C. Goodwin (Eds.), *Rethinking context: Language as an interactive phenomenon* (pp. 229–252). Cambridge: Cambridge University Press.
- Gutiérrez, K., & Punuel, W. R. (2014). Relevance to practice as a criterion for rigor. *Educational Researcher, 43*, 19–23.
- Hamann, T. (2003). Imagining the future of the anthropology of education if we take Laura Nader seriously. *Anthropology & Education Quarterly, 34*(4), 438–449.
- Heath, S. B., Street, B. V., & Mills, M. (2008). *Ethnography: Approaches to language and literacy research*. New York: Teachers College Press.
- Hernandez, S. J. (2013). *When institutionalized discourses become familial: Mexican immigrant families interpreting and enacting high stakes educational reform*. Doctoral dissertation, University of California, Berkeley.
- Hornberger, N. (2007). Biliteracy, transnationalism, multimodality, and identity: Trajectories across time and space. *Linguistics and Education, 8*(3-4), 325–334.
- Howe, K. R., & Dougherty, K. C. (1993). Ethics, institutional review boards, and the changing face of educational research. *Educational Researcher, 22*(9), 16–21.
- Hymes, D. (1964). Toward ethnographies of communication. *American Anthropologist, 66*(6), 1–34.
- Hymes, D. (2001/1972). On communicative competence. In Duranti, A. (Ed.), *Linguistic anthropology: A reader*. Massachusetts: Blackwell Publishing Ltd. pp. 53–74. (Reprinted from *Sociolinguistics: Selected Readings*, J. Pride and J. Holmes (Eds.), Harmondsworth: Penguin Books).
- Lam, W. S. E. (2004). Second language socialization in a bilingual chat room: Global and local considerations. *Language, Learning and Technology, 8*(3), 44–65.



- LeCompte, M. D., Schensul, J. J., & Weeks, M. R. (1999). Researcher roles. In M. D. LeCompte, J. J. Schensul, M. R. Weeks, & M. Singer (Eds.), *Ethnographer's toolkit: Researcher roles & research partnerships* (Vol. 6, pp. 2–72). Maryland: Altamira Press.
- Lipman, P. (2011). *The new political economy of urban education: Neoliberalism, race, and the right to the city*. New York: Routledge.
- López, P. D. (2012). *The process of becoming: The political construction of Texas' Lone STAAR System of accountability and college readiness*. (doctoral dissertation). University of Texas at Austin.
- Mangual Figueroa, A. (2014). La carta de responsabilidad: The problem of departure. In D. Paris & M. T. Winn (Eds.), *Humanizing research: Decolonizing qualitative inquiry with youth and communities* (pp. 129–146). California: Sage.
- Mangual Figueroa, A. (2016). Citizenship, beneficence, and informed consent: The ethics of working in mixed-status families. *International Journal of Qualitative Studies in Education*, 29(10), 66–85.
- Marcus, G. E. (1995). Ethnography in/of the world system: The emergence of multi-sited ethnography. *Annual Review of Anthropology*, 24, 95–117.
- Martínez, D. (2016). “This Ain’t the Projects”: Researcher reflexivity on the affordances and constraints of our research tools. *Anthropology & Education Quarterly*, 47(1), 59–77.
- Metro, R. (2014). From the form to the face to face: IRBs, ethnographic researchers, and human subjects translate consent. *Anthropology & Education Quarterly*, 45(2), 167–184.
- Moore, L. C. (2009). On communicative competence. . . in the field. *Language & Communication*, 29(3), 244–253.
- Nader, L. (1972). Up the anthropologist: Perspectives gained from studying up. In D. Hymes (Ed.), *Reinventing anthropology* (pp. 284–311). New York: Pantheon Books.
- Ochs, E. (1979). Transcription as theory. In E. Ochs & B. Schieffelin (Eds.), *Developmental pragmatics* (pp. 43–72). New York: Academic.
- Ochs, E. (1996). Linguistic resources for socializing humanity. In J. J. Gumperz & S. Levinson (Eds.), *Rethinking linguistic relativity* (pp. 407–438). Cambridge: Cambridge University Press.
- Pahl, K. (2007). Timescales and ethnography: Understanding a child’s meaning-making across three sites, a home, a classroom and a family literacy class. *Ethnography and Education*, 2(2), 175–190.
- Paperson, L. (2010). The postcolonial ghetto: Seeing her shape and his hand. *Berkeley Review of Education*, 1(1), 5–34.
- Paris, D., & Alim, H. S. (2014). What are we seeking to sustain through culturally sustaining pedagogy? A loving critique forward. *Harvard Educational Review*, 84(1), 85–100.
- Rymes, B. (2003). Relating word to world: Indexicality during literacy events. In S. Wortham & B. Rymes (Eds.), *The linguistic anthropology of education* (pp. 121–150). Connecticut: Praeger.
- Rymes, B. (2010). Classroom discourse analysis: A focus on communicative repertoires. In N. Hornberger & S. McKay (Eds.), *Sociolinguistics and language education* (pp. 528–548). Clevedon: Multilingual Matters.
- Sapir, E. (1968 [1924]). The grammarian and his language. In E. Mandelbaum (Ed.), *Selected writings of Edward Sapir* (pp. 150–159). California: University of California Press.
- Sapir, E. (1968 [1933]). Language. In E. Mandelbaum (Ed.), *Selected writings of Edward Sapir* (pp. 7–32). California: University of California Press.
- Toohy, K. (2008). Ethnography and language education. In N. Hornberger (Ed.), *Encyclopedia of language education* (2nd ed., pp. 1–9). New York: Springer.
- Vossoughi, S., & Gutiérrez, K. (2014). Toward a multi-sited ethnographic sensibility. *National Society for the Study of Education*, 113(2), 603–632.
- Whorf, B. L. (1995 [1941]). The relation of habitual speech, thought and behavior to language. In B. Blount (Ed.), *Language, culture, and society: A book of readings* (pp. 64–85). Illinois: Waveland Press, Inc.

- Wolcott, H. F. (1987). On ethnographic intent. In G. Spindler & L. Spindler (Eds.), *Interpretive ethnography of education at home and abroad* (pp. 37–60). New York: Lawrence Erlbaum Associates.
- Wortham, S. (2001). Language ideology and educational research. *Linguistics and Education*, 12(2), 253–259.
- Wortham, S. (2003). Introduction. In S. Wortham & B. Rymes (Eds.), *Linguistic anthropology of education* (pp. 1–30). Connecticut: Praeger.
- Zentella, A. C. (1997). *Growing up bilingual: Puerto Rican children in New York*. New York: Wiley-Blackwell.

---

# Researching Language Socialization

Paul B. Garrett

---

## Abstract

Language socialization research is concerned with the ways in which children or other novices (of any age) acquire language as well as the knowledge, skills, orientations, and practices that enable them to participate in the social life of a particular community. The language socialization approach is strongly interdisciplinary, drawing on insights and methods from anthropology, sociology, linguistics, psychology, education, and allied fields. Four key methodological features are essential to language socialization research: a longitudinal study design; field-based collection and analysis of a substantial corpus of naturalistic audio and/or audio-video data; a holistic, theoretically informed ethnographic perspective; and attention to both micro and macro levels of analysis, as well as to linkages between them. This integrated, multidisciplinary methodological approach has yielded important findings concerning such matters as the agency of learners, the effects of continuities and disjunctures between home- and classroom-based practices, and the sociocultural dynamics of language shift and other far-reaching processes of transformation and change.

---

## Keywords

Language socialization • Language acquisition • Child development • Ethnography • Culture

---

P.B. Garrett (✉)

Department of Anthropology, Temple University, Philadelphia, PA, USA

e-mail: [paul.garrett@temple.edu](mailto:paul.garrett@temple.edu)

## Contents

Introduction .....	284
Early Developments .....	285
Major Contributions .....	287
Works in Progress .....	289
Problems and Difficulties .....	290
Future Directions .....	292
Cross-References .....	293
Related Articles in the Encyclopedia of Language and Education .....	293
References .....	293

## Introduction

Language socialization is the human developmental process whereby a child or other novice (of any age) acquires the knowledge, skills, orientations, and practices that enable him or her to participate in the social life of a particular community. A key aspect of language socialization is the development of communicative competence, which involves acquiring proficiency in the use of a given language (or languages) as well as the culturally based knowledge that one needs in order to use language in culturally intelligible, socially appropriate ways (Garrett and Baquedano-López 2002; Ochs and Schieffelin 1984; Schieffelin and Ochs 1986a).

Language socialization occurs primarily through the child or novice's interactions with older or otherwise more experienced persons. In most cases, it involves peer interactions as well, and some language socialization studies take these as their primary focus (e.g., Howard 2007; Minks 2013; Smith 2016). Socializing interactions may be highly formalized and strongly regimented, designed explicitly to promote a particular kind of learning: a classroom lecture or a job-training workshop, for example. To a great extent, though, language socialization is the stuff of everyday social life: mundane interactions and activities ranging from the game of "peekaboo" played between a mother and her infant to the pointed but good-natured teasing that goes on among professional colleagues as they collaborate on a project, bringing their differing skills and varied levels of experience to the task at hand. This being the case, language socialization researchers who focus on formal education must venture outside of the classroom and other institutional settings in order to gain understanding of how formal education (i.e., classroom-based pedagogy or schooling) relates to, and articulates with, their subjects' home and community lives (Fader 2009; García-Sánchez 2014; Meek 2010; Moore 2004). As will be explained further, this holistic ethnographic perspective and the methodological framework out of which it emerges are among the key contributions of language socialization studies to research on language and education.

Although many kinds of social interactions can be regarded as sites of socialization, language socialization research is not just the study of such interactions for their own sake. Language socialization researchers seek to understand how such interactions – taken collectively, not as isolated instances – shape the developmental trajectories of individuals, how they fit into larger systems of cultural meaning and

practice, and how they are reproduced and transformed over the course of time. Such understandings are made possible by another hallmark of language socialization research: its longitudinal perspective, which involves close tracking of individual developmental processes over extended periods of time and investigation of the sociocultural and historical contexts within which those processes unfold.

Since its initial formulation in the early 1980s, the language socialization research paradigm has been resolutely interdisciplinary, combining the perspectives and insights of scholars in anthropology (particularly linguistic anthropology), linguistics (particularly applied linguistics), education, and other fields united by their commitment to investigating the relationships among language, culture, and society. A basic assumption of language socialization researchers is that the acquisition of language is inseparable from the acquisition of other kinds of social and cultural knowledge. As an individual comes to know a language, she or he also comes to understand the workings of everyday life in the community in which that language is spoken. This is perhaps nowhere more clearly seen than in interactions between young children and their primary caregivers, which were the main focus of the earliest language socialization studies (Schieffelin and Ochs 1986a, b). These studies showed that, in learning how to use the language(s) of their community, even at the earliest stages, children are also learning how to think, how to make sense of happenings in the world around them, how to relate to others, how to comport themselves, even how to feel in particular situations and how to express (or otherwise manage) those feelings. As a developmental process, then, language socialization is much more than a matter of learning to produce grammatically well-formed utterances. It is also a matter of learning to use language in socially and pragmatically appropriate, locally meaningful ways and as a means of engaging with others in the course of – indeed, in the creation and constitution of – everyday interactions and activities.

---

## Early Developments

The language socialization research paradigm was initially formulated in the early 1980s by Elinor Ochs and Bambi Schieffelin (Ochs and Schieffelin 1984; Schieffelin and Ochs 1986a, b). At that time, a significant body of research on language acquisition already existed, as did another on socialization, sometimes referred to as “enculturation.” But the two had developed quite separately from one another. Language acquisition research, rooted in developmental psychology and psycholinguistics, tended to treat language acquisition as a rather self-contained individual developmental process, largely ignoring the sociocultural contexts within which it occurs; conclusions drawn from studies conducted in mainstream North American and European settings were assumed to be universally valid. Meanwhile, socialization research, rooted in anthropology and sociology, was conducted in a variety of ethnographic settings worldwide, but gave little attention to the central role of language as the primary medium through which socialization occurs. Working in collaboration with researchers from several disciplinary backgrounds, including

linguistic anthropology, developmental psychology, sociolinguistics, applied linguistics, and education, Schieffelin and Ochs sought to combine the strengths of both of these established bodies of research and to bridge the gap between them.

One of the most important ways in which Schieffelin, Ochs, and their collaborators did so was by integrating the methods of these two bodies of research, particularly the longitudinal approach characteristic of psycholinguistic research on child language acquisition and the ethnographic approach characteristic of anthropological research on socialization. Schieffelin (1990) carried out her pioneering study among the Kaluli in Papua New Guinea, and Ochs (1988) conducted hers in Western Samoa. Another pioneering study was that of Shirley Brice Heath (1983), who examined language practices in two neighboring working-class communities, one black and one white, in the USA, and, in so doing, set an important precedent for all subsequent ethnographically oriented studies of schools and the communities in which they are situated. A signal event in the formulation of the language socialization research paradigm was the publication of a volume edited by Schieffelin and Ochs (1986b). Heath and several other researchers of various disciplinary backgrounds contributed chapters to this volume based on studies conducted in a broad range of sociocultural settings. Heath's was the only one of the 11 chapters that dealt directly with the relationship between language socialization and formal education or schooling; the rest focused primarily on household and community settings and on interactions between young (pre-school-age) children and their primary caregivers.

Numerous education-related studies carried out in the following years were influenced, to varying degrees, by the language socialization paradigm. Vasquez et al.'s (1994) examination of a bilingual (Spanish–English) working-class community in northern California focuses on continuities and discontinuities between home and school contexts, demonstrating that the relationship is a considerably more fluid (and potentially complementary) one than has generally been assumed, especially by researchers who have not ventured outside of classroom settings. In other studies, classroom-based interaction in institutional settings is the primary focus. Baquedano-López (2001) examines narrative practices as a resource for the socialization of ethnic identity in another Spanish–English bilingual setting: a Catholic parish in Los Angeles where a particular narrative, the story of the Virgin of Guadalupe, figures prominently in constituting a transnational, transgenerational Mexican-American community. He's (2001) work on Chinese heritage-language classes in the USA shows that, by combining elements of school, home, and community settings, they constitute important sites for the socialization of “traditional” Chinese cultural values and social roles.

Much of this work has been conducted in the USA, but there are various exceptions. Duff's (1995) study of English-language history lessons in Hungarian secondary schools, for example, examines significant changes in classroom discourse practices that have been fostered by political and educational reforms of the post-Soviet era. Cook (1999) focuses on Japanese classrooms, demonstrating important culturally based differences between Japanese and Western pedagogical practices, particularly in regard to participant structures. In Japanese classrooms, there is considerably greater emphasis on learning through interactions with peers;

knowledge and opinions are formulated and negotiated with relatively little direct intervention from the teacher. Particular emphasis is placed on the cultivation of attentive listening skills, which are considered crucial to successful interaction.

---

## Major Contributions

In whatever setting a language socialization study is conducted, and whatever specific linguistic and sociocultural phenomena constitute the main focus of investigation, four key methodological features are essential. These four features, which reflect the paradigm's interdisciplinary origins and are also the basis of its major contributions to the methodology of education research, are outlined below:

1. *Longitudinal study design.* Language socialization researchers closely track developmental changes in individual subjects by periodically observing and recording their participation in multiple kinds of interactions and activities – ideally, in a variety of social settings and over a developmentally significant span of time (Schieffelin 1990; Ochs 1988). In order for such tracking to be feasible, a language socialization study usually focuses on a relatively small number of children or novices: typically four to six, or a single small cohort, if the study is conducted in a school or other institutional setting. Qualitative depth of analysis is thus emphasized over quantitative breadth. Data in the form of naturalistic audio or audio-video recordings of the focal children or novices interacting with peers, caregivers, teachers, and other community members are collected at regular intervals (e.g., weekly or monthly), often over the course of a year or more of sustained fieldwork.
2. *Field-based collection and analysis of a substantial corpus of naturalistic audio and/or audio-video data.* Regular, periodic data collection as described above gives rise to a large corpus of recordings, typically 75–100 hours. A corpus of this size strikes a balance between ethnographic and longitudinal adequacy and practical manageability. Collection of the recordings is only a first step, however; in order for them to serve as a meaningful data set, the researcher must transcribe and annotate them. In most cases, this is accomplished with the aid of local consultants, normally members of the community in which the research is being conducted. For language socialization researchers, particularly those working outside of their own communities (as is typically the case), this close collaboration with native-speaking local consultants is indispensable (Kulick 1992). In addition to assisting with the most basic aspects of transcription, such as clarifying specific words and phrases captured in the recordings, consultants can bring to the researcher's attention layers of meaning that would otherwise escape his or her notice or understanding. Collaborative transcription also provides ongoing opportunities for the researcher to benefit from consultants' native-speaker intuitions about the use of particular linguistic forms and variants and their perspectives on many other aspects of social life within the local community.

3. *A holistic, theoretically informed ethnographic perspective.* This is achieved in part through sustained fieldwork and a commitment to ethnographic methods (including participant observation) and in part through familiarity with current theoretical issues and debates concerning such methods. Both depth and breadth of ethnographic observation are important in language socialization research. In addition to tracking individuals over the course of time (as described above), the researcher must observe and record in a broad variety of contexts in order to understand how different social settings may influence those individuals' language use and modes of participation (García-Sánchez 2014). Doing so allows the researcher to observe and record a broad range of persons as well; in effect, tracking a particular focal subject across contexts provides access to an entire social network and often to a broad cross-section of the community that includes fictive kin, peers, neighbors, etc. Although most recorded data are collected during everyday activities, the researcher must be attentive as well to exceptional events (i.e., those that occur rarely or unpredictably) and to periodic activities such as those associated with seasonal or ritual cycles. The systematic collection of recorded data that is central to any language socialization study may be supplemented by other methods, such as surveys, interviews, or elicitation sessions, depending on the kinds of data that are needed to address the study's central research questions. Whatever complementary methods are chosen, the researcher should have a thorough understanding of the theoretical issues in which they are based.
4. *Attention to both micro and macro levels of analysis and to linkages between them.* This can be considered part of the ethnographic perspective outlined above, but is important enough to merit consideration in its own right. Language socialization research is not just a matter of producing detailed ethnographic accounts of individual developmental processes and the local contexts in which they occur. An overarching goal is to understand how such individual developmental processes relate to larger sociocultural and historical processes (Garrett 2005; Meek 2010; Paugh 2012). As they analyze their recordings and other micro-ethnographic data, language socialization researchers are constantly on the lookout for patterns and principles that may also be discernible at macro levels of analysis. Likewise, when they make broader, macro-ethnographic observations, they consider various ways in which the patterns and principles thus identified may be in evidence, writ small, in their recorded data. Ultimately, the language socialization paradigm is comparative in perspective, recognizing that, while some aspects of language socialization are universal, others vary considerably from one sociocultural setting (or historical period) to another (Schieffelin and Ochs 1986b). Attention to micro-macro connections is an important means by which researchers are able to distinguish between the universal and the culturally specific and to consider the relationships between them.

Many education-related studies make excellent use of one or two of these four features, but outside of those that explicitly take the language socialization paradigm



as their framework, relatively few studies systematically integrate all four and take full advantage of their complementarity. It is this specific configuration of features that distinguishes language socialization studies from, for example, longitudinal studies that are confined to classroom settings and ethnographically oriented studies that do not involve systematic collection and close analysis of naturalistic data.

---

## Works in Progress

Prominent themes that were raised in the earliest language socialization studies have been carried forward and taken in productive new directions. Among researchers who work in schools and other educational settings, Heath's (1983) research has had enduring influence; in particular, it continues to inform recent studies that examine various kinds of continuities and discontinuities between children's home and community environments and those of the school and classroom. The dinner-table conversations of white middle-class American families, for example, have been shown to foster specific types of problem-solving orientations and to encourage children to display verbal skills that are expected and rewarded in the classroom and to orient them, from an early age, to the world of work (Paugh 2005). Meanwhile, research on children from immigrant and ethnic-minority communities in the USA and Europe suggests that, when classroom activities and modes of interaction draw on communicative practices and participant structures that are familiar to and inclusive of these children, their levels of participation and academic achievement may improve significantly (Gutiérrez et al. 2001). García-Sánchez (2014) explicitly addresses such matters by considering the ways in which Moroccan immigrant children in Spain cope with the sometimes tense politics of inclusion and exclusion that confront them in their public-school classrooms as well as in less regimented school-based settings (e.g., the playground during recess) and in nonschool-based neighborhood and community settings.

Fader's (2009) study of a Hasidic community in New York City focuses on the interplay of home and school socialization practices, particularly those concerning school-age girls' use of Yiddish and English. Yiddish functions as a language of ethnically and religiously based aspects of identity and is also implicated in the maintenance of community boundaries that separate the Hasidim from non-Hasidim, including other Jewish groups, whereas English is the language of boundary crossing, that is, communication with non-Hasidim, a duty that falls primarily on adult women. It is therefore important for Hasidic girls to be proficient speakers of both languages. Fader's work examines how girls are socialized to use these two codes in both home and school contexts, revealing that the girls develop among themselves patterns of bilingual language use that, in some respects, run counter to the wishes of their elders and the conventional expectations of the community as a whole. Fader's study, like a few others of recent years (e.g., Meek 2010; García-Sánchez 2014), also considers the differing meanings of literacy and literate practices across home, community, and school contexts and examines the complex interplay among them.

In addition to the aforementioned studies that explore the interface between home and school in various communities within the USA, several have been conducted in other societies worldwide. Watson-Gegeo's (1992) early work in the Solomon Islands examined disjunctures between home and school settings that tended to lead to poor educational outcomes. Here as in many other postcolonial societies, teachers relied heavily on highly formalized, rigidly formulaic modes of language use (e.g., modeling by the teacher followed by rote repetition, in chorus, by the students) that tended to perpetuate the gulf between the local vernacular and the language of instruction.

Moore (2004), however, finds that such situations can give rise to syncretic activities that effectively and productively meld home-based and school-based practices, thus transforming apparent discontinuities into new kinds of continuities. Moore observes that, in some northern Cameroonian communities, school-based practices such as "guided repetition," used in Islamic religious instruction as well as in secular classroom pedagogy based on French colonial models, have been taken up in home and community settings and have become the preferred method for socializing knowledge of traditional folktales. Elsewhere, Moore (2013) examines Qur'anic schools in northern Cameroon, showing that Fulbe children are socialized into locally preferred Muslim ways of being through sermons and related activities involving meaningful engagement with Arabic-language texts through their own primary language, Fulfulde. Howard (2004) likewise examines a complex blend of disjunctures and continuities between home and school settings, focusing on the socialization of respect in a Northern Thai community. Studies such as these problematize the notion that significant differences between home- and school-based practices inevitably lead to educational failure and call for special pedagogical interventions, if not major institutional reforms.

---

## Problems and Difficulties

Over the past three decades, the language socialization paradigm has proven to be both durable and flexible. As new generations of researchers have taken it up, they have updated it as necessary to keep pace with ongoing developments in the social sciences, such as new ways of conceptualizing communities in a "globalizing" world (Baquedano-López 2001; Duranti et al. 1995; García-Sánchez 2014). Perhaps the greatest challenge that remains is to realize the full potential of the paradigm as it was originally formulated; indeed, recent critiques of language socialization research typically reiterate issues that were explicitly raised in the paradigm's very earliest formulations, but have not yet been fully elaborated in field-based research.

The oldest and still most commonly raised criticism of language socialization research is that it focuses primarily on sociocultural reproduction: that it does not sufficiently address anomalous or unusual developmental outcomes and does not acknowledge the potential for innovation and change. It is true that language socialization studies have rarely dealt with abnormal, pathological, or otherwise atypical developmental trajectories; important exceptions include Ochs (2002) on

autism and Capps and Ochs (1995) on agoraphobia. As for innovation and change, a considerable amount of recent work has taken as its central concern the role of language socialization in language shift, language obsolescence, and other socially and culturally transformative processes, including language preservation and revitalization (e.g., Garrett 2005, 2007; Meek 2010; Minks 2013; Paugh 2012). A potential weakness of some studies in this vein, however, is that language socialization tends to be regarded primarily as a mechanism or conduit of changes that originate elsewhere and not as a locus and source of change in its own right. In many cases, language socialization can fairly readily be shown to be a domain of activity in which large-scale social, political, and economic transformations are manifested locally through the dynamics of face-to-face interactions and specific kinds of communicative practices, such as code-switching (e.g., García-Sánchez 2014; Garrett 2007; Paugh 2012).

It is always necessary, however, and often more challenging, to reverse this perspective and to consider as well that subtle changes in the most mundane of practices at local, micro levels may have surprisingly consequential ramifications that ultimately manifest themselves at macro levels, as Kulick (1992) demonstrated in his study of a case of rapid language shift. The language socialization paradigm's linking of ethnographic and longitudinal perspectives facilitates this latter mode of analysis, as the kinds of change in question may be discernible only by means of close observation over extended periods of time. However, the paradigm's methodological emphasis on qualitative depth over quantitative breadth may pose certain challenges in this same regard and in some cases may make it necessary for language socialization researchers either to partner with researchers of a more quantitative orientation or to find ways of integrating some such methods (e.g., large-scale surveys) into their own studies.

Another early insight that has been foundational to language socialization research, but remains to be further developed, is the idea that socialization is always a reciprocal process in which the child or novice's agency must be recognized and taken fully into account. Although virtually all language socialization studies acknowledge this basic fact, few have made it an explicit focus of inquiry. It may be that it is especially easy to lose sight of this issue in classroom-based research and in formal education settings more generally, where the environment tends to be configured and regimented in accordance with conventional "top-down" models of learning. Language socialization approaches that take the activity as a key unit of analysis and that stress the situated, emergent, co-constructed nature of learning processes lend themselves to just these kinds of settings, however, so there is good reason to expect that this gap in the literature will soon be addressed.

A final consideration is that, as the language socialization research paradigm has become more widely influential, it has become somewhat more diffuse. This is indicative of the paradigm's vitality and relevance; numerous researchers have taken it up, taking it in multiple directions in the process. However, a negative consequence is that it has become increasingly difficult for all of those engaged in language socialization research to find venues in which to come together, to exchange findings and insights, and to formulate shared goals and objectives. The

kind of strongly integrative comparative framework that characterized the first generation of language socialization studies, and that gave researchers a basis for sorting out the universal and culturally specific aspects of socialization, is now largely lacking. One consequence of this is that contemporary studies tend to be more narrowly ethnographic and more preoccupied with the specific theoretical concerns of the various disciplines; on the whole, today's researchers seem to be less inclined than their predecessors to consider the potential for their work to yield insights into the universal aspects of language socialization and of communicative practice more generally. The paradigm's founders, meanwhile, have upheld their commitment to this important line of inquiry (Duranti et al. 2012; Ochs and Schieffelin 1995; Schieffelin and Ochs 1996), offering hope that this and other unifying themes and integrative frameworks will receive greater attention in coming years.

---

## Future Directions

The challenges and problem areas that have been outlined here overlap with some of the most promising areas for future development. Kulick and Schieffelin (2004) have written of the need to be attentive to “bad” subjects: those individuals found in every community who persistently display culturally dispreferred traits and engage in nonnormative, “deviant” behaviors. Kulick and Schieffelin point out that “the focus on expected and predictable outcomes is a weakness if there is not also an examination of cases in which socialization does not occur, or where it occurs in ways that are not expected or desired” (p. 355). Language socialization research must account for reproduction as well as “why socializing messages to behave and feel in particular ways may also produce their own inversion” (p. 356). Certainly, unanticipated and undesired outcomes are frequently encountered in educational settings, but, thus far, they have received relatively little attention from language socialization researchers. As suggested previously, this general preference for dealing with normal or typical developmental trajectories, and with instances of “successful” socialization, also seems to have inhibited researchers from examining other atypical or less commonly encountered forms of language socialization that have been identified (though not necessarily regarded as such) by researchers in closely allied fields; Goodwin's (2004) study of an aphasic man's interactions with members of his family offers a striking example.

Another likely direction for future research is language socialization as it occurs later in the life-span, i.e., beyond childhood. The end of childhood, however defined in a given sociocultural and sociohistorical context (Berman 2014), is by no means the end of language socialization. Adults continue to be socialized into new roles, statuses, identities, and practices, many of which involve new ways of using language (Dunn 1999). Adults may find it necessary or desirable to master new registers or styles associated with changes in their vocational or professional lives or with new avocations or other activities that broaden their social horizons and involve participation in new communities of practice. Similarly, emigration, religious

conversion, and other significant life changes may make it necessary or desirable for adults to master new codes and/or new discursive genres, which may involve either spoken or written forms of language. A few studies have already marked this path, such as Duff et al.'s (2000) study of job-seeking immigrants in Canada. Thus far, there have been relatively few studies of adult learning in classroom settings, despite the fact that in the USA and other societies, formal education is increasingly regarded as a potentially lifelong enterprise (Ohta 1999).

Studies of language socialization of children and adults alike in educational settings underline the need for researchers to avoid conceptualizing human development as a matter of individuals acquiring static, predetermined bodies of cultural knowledge and linguistic forms. Both language and culture must be conceptualized in relational terms that capture their symbolically mediated, co-constructed, dynamically emergent qualities (Kramsch 2002). As Berman (2014) shows in her work in the Marshall Islands, it is important to consider ethnographically how such seemingly fundamental, cross-culturally applicable notions as childhood and age are locally conceptualized, negotiated, and made relevant in particular kinds of interactions.

Similar concerns inform language socialization researchers' non-teleological perspectives on the outcomes of socialization. Individual development must be understood to be variable, contingent, nonlinear, and open-ended. Differing degrees and types of developmental progress and multiple kinds of "successful" outcomes must be recognized and accounted for – even when the arena of investigation is a classroom or other institutional context in which the participants themselves may differentiate between "success" and "failure" in much starker terms.

---

## Cross-References

- ▶ [Ethnography and Language Education](#)
- ▶ [Linguistic Ethnography](#)
- ▶ [Microethnography in the Classroom](#)

---

## Related Articles in the Encyclopedia of Language and Education

Patricia A. Duff and Stephen May (eds): [Encyclopedia of Language and Education, Language Socialization](#). In Volume: Language Socialization

---

## References

- Baquedano-López, P. (2001). Creating social identities through *doctrina* narratives. In A. Duranti (Ed.), *Linguistic anthropology: A reader* (pp. 343–358). Oxford: Blackwell.
- Berman, E. (2014). Negotiating age: Direct speech and the sociolinguistic production of childhood in the Marshall Islands. *Journal of Linguistic Anthropology*, 24(2), 109–132.

- Capps, L., & Ochs, E. (1995). *Constructing panic: The discourse of agoraphobia*. Cambridge, MA: Harvard University Press.
- Cook, H. M. (1999). Language socialization in Japanese elementary schools: Attentive listening and reaction turns. *Journal of Pragmatics*, 31(11), 1443–1465.
- Duff, P. A. (1995). An ethnography of communication in immersion classrooms in Hungary. *TESOL Quarterly*, 29(3), 505–537.
- Duff, P. A., Wong, P., & Early, M. (2000). Learning language for work and life: The linguistic socialization of immigrant Canadians seeking careers in healthcare. *The Canadian Modern Language Review/La Revue Canadienne des Langues Vivantes*, 57(1), 9–57.
- Dunn, C. D. (1999). Toward the study of communicative development as a life-span process. *Anthropology and Education Quarterly*, 30(4), 451–454.
- Duranti, A., Ochs, E., & Ta'ase, E. K. (1995). Change and tradition in literacy instruction in a Samoan American community. *Educational Foundations*, 9(4), 57–74.
- Duranti, A., Ochs, E., & Schieffelin, B. B. (Eds.). (2012). *The handbook of language socialization*. Oxford: Wiley Blackwell.
- Fader, A. (2009). *Mitzvah girls: Bringing up the next generation of Hasidic Jews in Brooklyn*. Princeton: Princeton University Press.
- García-Sánchez, I. M. (2014). *Language and Muslim immigrant childhoods: The politics of belonging*. Oxford: Wiley Blackwell.
- Garrett, P. B. (2005). What a language is good for: Language socialization, language shift, and the persistence of code-specific genres in St. Lucia. *Language in Society*, 34(3), 327–361.
- Garrett, P. B. (2007). Language socialization and the (re)production of bilingual subjectivities. In M. Heller (Ed.), *Bilingualism: A social approach* (pp. 233–256). New York: Palgrave Macmillan.
- Garrett, P. B., & Baquedano-López, P. (2002). Language socialization: Reproduction and continuity, transformation and change. *Annual Review of Anthropology*, 31, 339–361.
- Goodwin, C. (2004). A competent speaker who can't speak: The social life of aphasia. *Journal of Linguistic Anthropology*, 14(2), 151–170.
- Gutiérrez, K., Baquedano-López, P., & Alvarez, H. (2001). Using hybridity to build literacy in urban classrooms. In M. de la Luz Reyes & J. J. Halcón (Eds.), *The best for our children: Latina/Latino voices in literacy* (pp. 122–141). New York: Teachers College Press.
- He, A. W. (2001). The language of ambiguity: Practices in Chinese heritage language classes. *Discourse Studies*, 3(1), 75–96.
- Heath, S. B. (1983). *Ways with words: Language, life, and work in communities and classrooms*. Cambridge: Cambridge University Press.
- Howard, K. M. (2004). Socializing respect at school in Northern Thailand. *Working Papers in Educational Linguistics*, 20(1), 1–30.
- Howard, K. M. (2007). Kinterm usage and hierarchy in Thai children's peer groups. *Journal of Linguistic Anthropology*, 17(2), 204–230.
- Kramsch, C. (Ed.). (2002). *Language acquisition and language socialization: Ecological perspectives*. New York: Continuum.
- Kulick, D. (1992). *Language shift and cultural reproduction: Socialization, self, and syncretism in a Papua New Guinean village*. Cambridge: Cambridge University Press.
- Kulick, D., & Schieffelin, B. B. (2004). Language socialization. In A. Duranti (Ed.), *A companion to linguistic anthropology* (pp. 349–368). Oxford: Blackwell.
- Meek, B. A. (2010). *We are our language: An ethnography of language revitalization in a northern Athabaskan community*. Tucson: University of Arizona Press.
- Minks, A. (2013). *Voices of play: Miskitu children's speech and song on the Atlantic Coast of Nicaragua*. Tucson: University of Arizona Press.
- Moore, L. C. (2004). Multilingualism and second language acquisition in the Northern Mandara Mountains of Cameroon. In G. Echu & S. G. Obeng (Eds.), *Africa meets Europe: Language contact in West Africa* (pp. 131–147). New York: Nova Science Publishers.

- Moore, L. C. (2013). Qur'anic school sermons as a site for sacred and second language socialization. *Journal of Multilingual and Multicultural Development*, 34(5), 445–458.
- Ochs, E. (1988). *Culture and language development: Language acquisition and language socialization in a Samoan village*. Cambridge: Cambridge University Press.
- Ochs, E. (2002). Becoming a speaker of culture. In C. Kramsch (Ed.), *Language acquisition and language socialization: Ecological perspectives* (pp. 99–120). London: Continuum.
- Ochs, E., & Schieffelin, B. B. (1984). Language acquisition and socialization: Three developmental stories and their implications. In R. A. Shweder & R. A. LeVine (Eds.), *Culture theory: Essays in mind, self and emotion* (pp. 276–320). Cambridge: Cambridge University Press.
- Ochs, E., & Schieffelin, B. B. (1995). The impact of language socialization on grammatical development. In P. Fletcher & B. MacWhinney (Eds.), *The handbook of child language* (pp. 73–94). Cambridge, MA: Basil Blackwell.
- Ohta, A. S. (1999). Interactional routines and the socialization of interactional style in adult learners of Japanese. *Journal of Pragmatics*, 31, 1493–1512.
- Paugh, A. L. (2005). Learning about work at dinnertime: Language socialization in dual-earner American families. *Discourse and Society*, 16(1), 55–78.
- Paugh, A. L. (2012). *Playing with languages: Children and change in a Caribbean village*. New York: Berghahn.
- Schieffelin, B. B. (1990). *The give and take of everyday life: Language socialization of Kaluli children*. Cambridge: Cambridge University Press.
- Schieffelin, B. B., & Ochs, E. (1986a). Language socialization. *Annual Review of Anthropology*, 15, 163–191.
- Schieffelin, B. B., & Ochs, E. (Eds.). (1986b). *Language socialization across cultures*. Cambridge: Cambridge University Press.
- Schieffelin, B. B., & Ochs, E. (1996). The microgenesis of competence: Methodology in language socialization. In D. Slobin, J. Gerhardt, A. Kyratzis & J. Guo (Eds.), *Social interaction, social context, and language: Essays in honor of Susan Ervin-Tripp* (pp. 251–264). Mahwah, NJ: Lawrence Erlbaum Associates.
- Smith, B. K. (2016). Turning language socialization ontological: Material things and the semiotics of scaling time in Peruvian Aymara boyhood. *Language and Communication*, 46, 42–50.
- Vasquez, O. A., Pease-Alvarez, L., & Shannon, S. M. (1994). *Pushing boundaries: Language and culture in a Mexican community*. Cambridge: Cambridge University Press.
- Watson-Gegeo, K. A. (1992). Thick explanation in the ethnographic study of child socialization: A longitudinal study of the problem of schooling for Kwara'ae (Solomon Islands) children. *New Directions for Child Development*, 58, 51–66.

---

# Discourse Analysis in Educational Research

Doris Warriner and Kate T. Anderson

---

## Abstract

Discourse analysis as a method of inquiry has improved our collective understanding of teaching and learning processes for at least four decades. This chapter provides some historical context for understanding the emergence of discourse analysis within educational research, describes some of the different ways that discourse analysis continues to be used and useful in educational research, and synthesizes scholarship that has influenced how discourse analysis has enhanced educational research. It explores key contributions in the study of discourse, including how underlying social systems shape (and are shaped by) interaction, how identities are constructed in and through talk, the relationship between interaction and learning in both formal and informal educational contexts, and how embodiment, multimodality, and virtual spaces offer new sites of analysis, which raises important questions about what new modes of communication imply for discursive methods of research and representation. It also covers four major approaches to discourse analysis in education – anthropological, narrative, classroom-based, and critical – and shows that the study of language and discourse in education has blossomed into a dynamic and interdisciplinary endeavor. Although educational researchers using discourse analysis as a method/tool of inquiry continue to wrestle with questions of context, definitions of “text,” and

---

D. Warriner (✉)

Department of English, College of Liberal Arts and Sciences, Arizona State University, Tempe, AZ, USA

e-mail: [doris.warriner@asu.edu](mailto:doris.warriner@asu.edu)

K.T. Anderson (✉)

Division of Educational Leadership and Innovation, Arizona State University, Tempe, AZ, USA

e-mail: [kate.t.anderson@asu.edu](mailto:kate.t.anderson@asu.edu)



notions of discourse, this approach to inquiry remains extremely useful and influential. After describing recent advances in the study of discourse within educational research and the problems and challenges that remain, the chapter concludes with a discussion of future directions and suggests recommended additional reading.

---

### Keywords

Discourse • Ethnography of communication • Interactional sociolinguistics • Narrative inquiry • Multimodal discourse analysis • Mediated discourse analysis • Linguistic anthropology • Methods of inquiry • Educational research

### Contents

Introduction .....	298
Early Developments .....	299
Major Contributions .....	300
Anthropological Investigations of Discourse .....	300
Narrative Analysis .....	301
Classroom-Based Studies of Discourse .....	302
Critical Approaches .....	303
Work in Progress .....	304
Problems and Difficulties .....	305
Future Directions .....	306
Cross-References .....	307
Related Articles in the Encyclopedia of Language and Education .....	307
References .....	308

---

### Introduction

Discourse analysis now has a decades long history in educational research. Recent and continued work continues to use a variety of perspectives, insights, and methods to analyze discourse – defined as language in use, the relationship between text and context, the ideological effects of discourse, or the ways that actions and texts beyond language are an integral part of meaning making. Educational research using discourse analysis has enhanced our collective understanding of teaching and learning processes, as well as the historical, social, and political factors that influence those processes. There is also now a journal, *Classroom Discourse*, begun in 2010, devoted to issues of discourse and its analysis in education, both formal and informal.

This chapter provides an overview of historical influences on current approaches to discourse analysis in educational research and the ways that educational researchers continue to draw on and create new theoretical and methodological traditions to analyze discourse. Constraints of space require that we narrow our focus to discourse analysis used in first language research. This overview is not meant to be taken as comprehensive but, instead, to spark interest in one or more of the approaches mentioned and promote further intellectual inquiry.

## Early Developments

As early as 1959, the sociologist Erving Goffman emphasized the importance of investigating face-to-face interaction in order to understand how individuals construct and negotiate meaning or accomplish a particular presentation of self over time. More than a decade later, Cazden et al. (1972) and others drew on those insights to examine the cross-cultural aspects of communication and to illustrate how theories and methods from linguistic and cultural anthropology might be applied to questions of educational opportunity and access. In addition to looking at communicative competence *in relation to* questions of culture and context, such work examined how assumptions about what constitutes “correct” ways to talk (or write) might impact the educational experiences of children from traditionally marginalized groups in US society. This work fundamentally reshaped how many educational researchers viewed the role of language in education, discourse in learning, and culture in communication.

Around the same time, there was a growing interest in the organization of turn-taking in conversation (Sacks et al. 1974) and initiation-response-evaluation (IRE) sequences (Mehan 1979) present in most classroom discourse. Careful analysis of conversational routines became the foundation for conversation analysis (CA), a field that grew out of ethnomethodology and contributed a great deal to our understanding of discourse and interaction as co-constructed in and through talk. Influenced by such insights, Michaels (1981) later investigated the distinct ways that children from different class and race backgrounds told stories during sharing time activities in a first-grade classroom (and different teachers’ reactions to those practices). As Cazden (1988) observed, “differences in how something is said, and even when, can be matters of only temporary adjustment, or they can seriously impair effective teaching and accurate evaluation” (p. 3). A limitation of such approaches is the assumption that all the information necessary to analyze and understand an interaction are located within the interaction itself (see Wooffitt 2005 for a comprehensive discussion of related methodological debates).

In contrast, the ethnography of communication assumes that the analyst cannot fully understand individual speech events or speech acts without attending to questions of situation, culture, context, audience, or purpose. Following Hymes (1974), educational anthropologists conducted ethnographies of communication in order to investigate the gap between the different ways with words (e.g., Heath 1983) that children from different race, class, and cultural backgrounds learn in their communities, the kinds of communicative practices and participation structures that are valued in most classroom contexts, and the consequences when youth are from marginalized backgrounds. Early ethnographies of communication looked outside of classroom contexts in order to expand notions of what is possible and desirable in the classroom. This approach has influenced a number of ethnographic studies of talk and interaction across a range of educational (formal and informal) settings over the past three and a half decades.

Other insights emerging from the ethnography of communication included the notions of *discourse strategies* including contextualization cues in interaction – or

the contextual information conveyed, for example, in speaker's intonation or tone or with a particular gesture or gaze that accompanies a bit of interaction or talk (Gumperz 1982). By enhancing our theoretical understanding of the different ways that particular verbal utterances might gain meaning from nonverbal cues, Gumperz advanced an influential theory of how identities are displayed, constructed, and performed in and through talk in a minute-by-minute fashion, unfolding over time.

Gumperz's theories of contextualization and Goffman's interest in the minute-by-minute construction of identity (and meaning) in face-to-face interaction significantly influenced interactional sociolinguists, an approach that draws from theories and methods in both sociology and linguistics to examine the discourse strategies used by people from different cultural, ethnic, racial, or gender backgrounds. This early work acknowledged the importance of looking beyond what was said to consider how things were said (including tone, gesture, etc.) and to what effect. Building on these early works and the questions of context that emerged, the study of language and discourse in education has blossomed into a dynamic and interdisciplinary endeavor. In the following sections, we outline four major approaches to discourse analysis in education – anthropological, narrative, classroom based, and critical.

---

## Major Contributions

### Anthropological Investigations of Discourse

Across studies in linguistic anthropology, researchers taking an anthropological approach to the study of language and discourse demonstrate the value of combining ethnographic methods of data collection (e.g., long-term participant observation, document collection, and individual interviews) with a close analysis of discourse in order to provide a grounded and nuanced account of the specific, local, and complicated ways that institutional and social processes (e.g., bureaucratic, social, economic, and political) are related to individual identity construction or performance. Understanding that discourse and interaction serve as local practices that mediate the relationship between institutional ideologies and individual identities, this work provides important insights into the relationship between discourse, learning, and identity. In an edited volume that explicitly attempts to bridge the fields of linguistic anthropology and education, *Linguistic Anthropology of Education* (Wortham and Rymes 2003), contributors demonstrate how conducting ethnographically grounded analyses of interactional processes illuminate key questions and processes in educational research (e.g., situated learning, language socialization, developing “competence,” and language and literacy ideologies).

A number of book-length ethnographies are noteworthy for their careful examination of the relationship between talk (or text) and surrounding context. For instance, Morgan's (2009) *The Real Hip-hop: Battling for Knowledge, Power, and Respect in the LA Underground* examined the confluence of linguistic, sociological, and political features of hip-hop drawn from her 7 years of ethnographic study of an LA youth community organized, in part, around freestyle rap battles and other cultural aspects of

hip-hop. By analyzing detailed aspects of language use as integral to the formation and evolution of this locally situated cultural movement, Morgan brought detailed examination of youths' linguistic practices in lyrics and interviews to bear on larger sociopolitical contexts and ideologies that shape and are shaped by local cultural practice. Rampton's *Language in Late Modernity: Interaction in an Urban School* (2008) demonstrates how combining a close analysis of interaction with long-term participant observation and document collection provides valuable insights into learning processes. Through his vivid analysis of classroom talk in relation to context, he addressed important questions about the role of social class, traditional authority relationships in schools, popular media culture, and the experiences of learning at school. Examining transcripts from three extensive case studies, Rampton explored the intersections between identity, insecurity, and the organization of talk for marginalized youth in school contexts. In each of these ethnographic explorations, the authors analyzed discourse closely to illuminate the complicated, often contradictory, aspects of identity performance in and through language as well as the contested nature of the relationship between individual identity construction and institutional constraints.

## Narrative Analysis

Another approach that has captured the interest of an increasing number of educational researchers is narrative analysis. This approach permits an examination of the complicated ways that narrators position themselves in and through talk by creating certain voices (and thus identities) for the characters in their story, by constructing and enacting particular identities as the narrator, and by providing critical commentary on the institutional or societal constraints on their individual situations. For a discussion of the potential utility of this analytic approach for educational research, see Clandinin and Connelly (2004), and for a thorough overview of the approach, see Clandinin (2013).

Many studies have examined the particular ways that identities are taken up, constructed, enacted, or performed in and through narrative or storytelling in particular educational contexts and have contributed to our understanding of the power of narrative to accomplish certain presentations of self, promoted academic learning, and facilitated interactional agendas. Orellana (1999), looking at the written narratives of her Latina and Latino student writers in Grades 1, 2, and 3, also demonstrated how storytelling "provides a space in which identities can be constructed" and narrators can "position [them]selves in relation to others" (p. 65). A recent volume, *Narrative Discourse Analysis for Teacher Educators: Managing Cultural Differences in Classrooms*, edited by Rex and Juzwik (2011), evidences the growing popularity of narrative approaches for analysts of classroom discourse, including practicing teachers in this case as an audience. Contributors to this volume discussed the ways that narratives offer students and teachers "value-laden stances" around issues of cultural difference and discuss ways that narratives, as a site for analysis and pedagogy, can be used to engender new forms of teacher preparation, classroom practices, and analysis of classroom discourse using critical and interactional lenses.

## Classroom-Based Studies of Discourse

Book-length studies based in analysis of the spoken language of the classroom date back to Courtney Cazden's aforementioned early work (Cazden et al. 1972; Cazden 1988), along with other examinations of the ways language practices and social organizational features of classroom talk make up the life of a classroom and shape opportunities to learn and participate therein. Informed by a range of methodological and theoretical approaches such as interactional sociolinguistics, the ethnography of communication, linguistic anthropology, and critical studies of discourse, scholars have examined the ways that contexts matter, not only for understanding local practices but also for their constitution in moments and over time. Classroom interactions entail the negotiation of roles, relationships, what count as text and context, and how various forms of participation take shape and are differently valued (see Green and Dixon 1993, for an early and thorough summary of the history of this tradition). Within classroom-based studies of discourse, microethnographic approaches grew out of earlier ethnographies and work within the tradition of ethnography of communication.

Microethnographic studies consider events that occur in a bounded learning context (often a classroom) and zoom in to incorporate fine-grained detail in order to then show how the unfolding of interaction at the level of sequential organization draws from and shapes not only the daily life of classrooms but also more macro-scale issues (e.g., opportunity, access, definitions of ability). Bloome and colleagues (2004) outlined methods within this tradition and situated it in light of similar approaches concerned with relating micro-interactional discourse events in classrooms to macro-social educational issues. As the first monograph to discuss how to carry out a microethnographic approach to analysis of classroom discourse, Bloome and colleagues' contribution extends the reach of much earlier studies that paved the way for this approach to discourse analysis (e.g., Cazden et al. 1972; Erickson 1982).

A more recent trend in studies of classroom discourse includes books aimed at helping teachers engage in discourse analysis of their own classrooms. Rex and Schiller's (2009) *Using Discourse Analysis to Improve Classroom Interaction* set out to foster teachers' interactional awareness and improve equity in classrooms. The authors detailed the affordances of different theoretical approaches to classroom interaction (e.g., critical, constructivist, and sociocultural) to show how different assumptions and beliefs about interaction shape learning opportunities and outcomes. Drawing primarily from a "language-in-use" approach to discourse, Rex and Schiller examine "who can say and do what, with whom, when, for what purposes, and with what outcomes" to show how understanding is built through talk (p. xii) using detailed examples of analysis from their own work. Rymes' (2009, 2016) *Classroom Discourse Analysis: A Tool for Critical Reflection* also provides teachers with tools and resources, as well as theoretical lenses, for understanding classroom discourse. Specifically, Rymes offers readers tools from the tradition of critical discourse analysis and organized the book according to three dimensions of discourse and identity to be taken up in analysis – social context, interactional context, and individual agency. Her book thus aims to prepare teachers to unpack

classroom interactions according to the resources students and teachers draw on to organize turn-taking as well as signal interpretations and values toward ongoing talk.

## Critical Approaches

By the early 1990s, explicitly “critical” approaches to discourse analysis were emerging. Most critical discourse analysts are primarily concerned with illustrating how the close analysis of spoken or written discourse is informed by analysis of structural social (and power) relations. James Gee (2014a, b), in the newest editions of his widely recognized companion texts, provides accessible yet nuanced description of the theoretical underpinnings, analytic tools, and potential contributions of a critical approach to the analysis of discourse. For a thorough and nuanced discussion of critical discourse analysis in educational research, see Rogers (2011), and for an exhaustive review of its use in literacy education specifically, see Rogers and Schaenen (2014). We discuss next two more recent developments to grow out of critical approaches to discourse – multimodal discourse analysis and mediated discourse analysis.

**Multimodal Discourse Analysis.** Multimodal discourse analysis (MMDA) began in the mid-1990s and has been influential in many realms of educational research concerned with how power operates in social interactions. Like critical discourse analysis, MMDA grew out of Halliday’s (1973) theory of social semiotics, with Gunther Kress’ and colleagues (e.g., 2001) early work catalyzing MMDA’s focus on examining the material resources we draw on to communicate – for example, the physical and immaterial ways that font and written text, or music and image, work together to convey meaning to be interpreted. More recently, Kress (2013) defined MMDA’s aims as an approach as developing analytic tools for describing and analyzing how texts (understood broadly, beyond just written texts) display elements of the social order out of which they spring and are also resources for future meaning making. Multimodality is not a theory but a set of approaches encompassing a variety of theories that together share the aim of analyzing how the confluence of different modes and media shapes opportunities to make and interpret meaning (see Jewitt 2009; Kress 2013, for overviews of MMDA’s underpinnings and various approaches).

Jewitt and Jones (2007) illustrated the use of MMDA for education in a study of how ability was constructed in UK secondary school English curricula. Specifically, they consider the silent production and reproduction of “ability” through descriptions of the ways that discourses are realized across modes in the classroom, for example, in the ways that reading groups are organized according to supposed ability levels. They push back against discursive constructions of ability that suggest inherent (biological or psychological) sources of student ability by examining how discourses are realized in the classroom across modes and how these local realizations draw on and further shape more widely available discourses as well. Jewitt (2008) highlighted how changes in communication and education over the last few decades (e.g., Web 2.0, new knowledge economy, increased access to technology in

classrooms for some and not others) have shaped what it means to be literate and how literacies are understood and studied. Jewitt's main argument is that the different ways that knowledge is represented and recognized shape what is learned and how, and learning and teaching are increasingly understood as multimodal practices that include "gesture, sound, image, movement, and other forms of representation" (Jewitt 2008, p. 246).

**Mediated Discourse Analysis.** Another recent approach within the family of critical studies of discourse is that of mediated discourse analysis (MDA), which identifies physical action as the primary unit of analysis, rather than ethnographic events or stretches of text or talk. Widely recognized as beginning with Ron Scollon's (e.g., 1999) work in linguistics, MDA's aims include understanding how social actions can be linked to macro-social issues of power. Context in MDA is seen as both immediately and sociohistorically located, and therefore actions are seen as integral to understanding discourse. Like the role of text in MMDA, discourse in MDA is seen to shape social actions and identities as one of many cultural resources that link our actions to our contexts and social structures. See Scollon and de Saint-Georges (2013) and Wohlwend (2013) for recent overviews of this approach.

Lewis and Tierney (2013) draw on MDA to examine how emotions are linked to language and identity in the ways that talk, text, and participation mediate, or mutually shape, them over time in classrooms. By taking a meditational view on discourse and emotion, they claimed a broadened view on critical literacy that places emotion in a central sociocultural role for learning. Wohlwend (2009) uses MDA to study how kindergarten girls negotiated gendered identities and discourses through pretend play around Disney princesses. Specifically, she examines "dynamic relationships between practices, materials, and discourses" to analyze how children's texts and play (as mediated actions) changed objects into "design products" that were integral to their local social practices and shared values (p. 62).

---

## Work in Progress

Current works in progress reflect the fact that educational researchers draw upon and bring together different theoretical and methodological approaches to discourse analysis in ways that acknowledge changing educational and communication landscapes. For instance, James Gee, who has been writing about discourse analysis since the 1990s, in his book *Unified Discourse Analysis: Language, Reality, Virtual Worlds and Video Games* (2014c), suggests a unifying theory of discourse, language, action, interaction, and meaning. He outlines a "new kind of discourse analysis" (p. 1) that keeps up with changes in the types of worlds we create, interact within, and through which we shape affiliations and identities (e.g., video games, virtual worlds, social media). Following from earlier treatments of discourse analysis that acknowledge the importance of context and our ever-changing positions within it for understanding discourse and meaning, Gee discusses discourse not just as a way of doing but a way of being. Therefore, he charts territory in discourse analysis in education that might open up new avenues for interdisciplinary discussion that

crosses previously held boundaries through a common language and sensibility toward theory and method.

Some scholars have also paid increased attention to the temporal and spatial dimensions of discourse, including methodological implications of these theoretical advancements. For example, Blommaert (2013), in *Ethnography, Superdiversity and Linguistic Landscapes: Chronicles of Complexity*, discusses the ways that physical space is also always social, cultural, and political. He highlights the ways that linguistic structures at multiple levels illuminate social, cultural, and political structure. Where we are in the world and the opportunities to make meaning and the ways at our disposal to do so shape who will hear us and how they will interpret us. In other words, discursive features such as turn-taking, micro-linguistic features such as pronunciation, and macrolinguistic aspects of discourse such as ideologies all can inform our understanding of how the ways we have to use language in and across spaces shape social structure and culture. Blommaert argues that globalization, with its new modes of mobility and increasing realities of superdiversity, reflects the need to account for new types of complexity within the nested layers of systems and spaces through which discourse flows, which require new forms of analysis.

Other new directions in discourse analytic work have similarly blurred theoretical and methodological boundaries, for example, between human and nonhuman, and have questioned the role of embodiment, materiality, and issues of becoming as they relate not only to learning but to the conceptualizations of curricula, ontology, and research paradigms. By blurring distinctions between previously held dichotomies such as symbolic/material and body/mind, such work explores issues of place, space, embodiment, as well as knowing, being, and doing through the lens of discourse as ecologically mediated (e.g., de Freitas and Sinclair 2014).

---

## Problems and Difficulties

For educational scholars interested in using discourse analysis in their research, it is important to recognize that there are multiple ways of defining the term “discourse” as well as multiple intellectual histories associated with the term. Additionally, it is necessary to think critically about questions of context and contextualization and the methodological implications for theoretically nuanced notions of space and time. What is the unit of analysis? How is context defined? What historical moments have influenced a particular literacy event, narrative account, researcher gaze, or location of the subject? The answers to such questions will influence decisions regarding the unit of analysis, how text and context are defined, and what methods are used in the bounding and analysis of texts.

Because there are so many different theoretical and methodological approaches to analyzing discourse available to new researchers in the field, a persistent challenge remains choosing from among the available approaches and understanding the sets of assumptions and ways of seeing that come along with them (and by extension what ways of knowing are in turn obscured). Because it is important for educational researchers to recognize that the terms *discourse* and *discourse analysis* have been



used by researchers to mean a variety of things, discourse analysis in educational research must be understood as an eclectic set of theoretical and methodological approaches to the systematic study of discourse, language in use, notions of context and contextualization, questions of power, and increasingly discussed issues of embodiment, spatiality, virtuality, and complex ecologies shaping educational contexts.

Contributing to this ongoing challenge is the unavoidable fact that in discourse analysis, context is not only a theoretical construct but also seen as something to be discovered, analyzed, or created by the researcher. Context can be defined in a variety of ways, for different purposes, and with different goals. Context can and does change in and through interaction (Goodwin and Duranti 1992; Rampton 2008; Rymes 2009, 2016). Similarly, even though phenomena outside, or larger than, text (e.g., ideologies, policies, events, practices) do influence the content, shape, and interpreted meaning of text, the text also simultaneously influences and shapes the surrounding context. Sometimes more than one such factor/influence are shaped at once. This dynamic and always emergent tension between our use of language and the reality that both influences and is influenced by how we can and do use language remains a central challenge for discourse analysts, regardless of their intellectual leanings in the analysis and representation of data.

Questions of authority and voice also remain unresolved. Even with the benefit of participant observation and/or document collection and analysis, the discourse analyst cannot be sure that his/her interpretation of the meaning of an utterance reflects the author's intended meaning. There is also the challenge of disentangling the author from the animator (Goffman 1981). As Goffman (1981) has shown, because speakers often use words and/or express views and opinions that are not their own, it becomes important to distinguish the "author" of a statement from the one animating or voicing another person's statement (see also Bakhtin 1981).

Finally, there are numerous but under-theorized challenges involved with analyzing discourse in digital, online, or computer-mediated spaces. Questions that emerge include: what is the relationship between the discourse one sees as a viewer of a digitally mediated text and the discourse that exists behind the scenes (of the designers and creators responsible for the discourse that is visible to the public/audience)? What is the relationship between the visual and print? Between ideologies and institutions? Between individuals, discourse practices, and identities?

---

## Future Directions

Educational researchers are attracted to the systematic analysis of discourse for a variety of reasons. Some see value in the close analysis of the minute-by-minute construction of talk, identity, positioning, and meaning when two or more people interact. Others prefer to connect individual practices with historical structuring influences, focusing on the ways that language mediates the two. Still others want to find textual evidence for the claim that all relations are power laden and argue that we must therefore explicitly foreground power in our analyses. More recently, analyses that blur conceptual, theoretical, and disciplinary boundaries seek new

methods and connections that discourse analysis might offer. Combining elements from different theories and methods of discourse analysis has become more common than rare, as the thoughtful combination of multiple approaches to the study of discourse allows researchers to continue addressing old questions in new ways as well as find new questions to pose, including those that respond to the ever-changing nature of communication, location, and being.

Educational researchers using discourse analysis as a method/tool of inquiry continue to wrestle with questions of context, definitions of *text*, and notions of discourse. Moving forward both theoretically and methodologically in this arena requires a continued reexamination of the relationship between text and context as well as the ever present dimensions of power that influence not only the researcher's gaze but also the voices represented in the analysis and interpretation of data. It is also going to be important for educational researchers to analyze and document the complex ways that digital technologies provide spaces for the emergence, reproduction, and transformation of new and different kinds of discourses. To understand the nature of what is going on in, around, with, and because of discourse (and why it matters to processes of teaching, learning, and social identification), educational researchers may need a greater number of theoretical insights, enhanced methods of analysis, and increased tolerance for ambiguity and change. Such a reexamination and reevaluation has profound implications for the ways we theorize and understand connections between modes of communication, modes of engagement, and learning processes for learners (adults and children) in and out of school settings.

---

## Cross-References

- ▶ [Conversation Analytic Approaches to Language and Education](#)
- ▶ [Interactional Approaches to the Study of Classroom Discourse and Student Learning](#)
- ▶ [Linguistic Ethnography](#)
- ▶ [Microethnography in the Classroom](#)
- ▶ [Researching Multimodality in Language and Education](#)
- ▶ [Researching Timescales in Language and Education](#)
- ▶ [Social Class in Language in Education Research](#)

---

## Related Articles in the Encyclopedia of Language and Education

- Betsy Rymes: [Language Socialization and the Linguistic Anthropology of Education](#). In Volume: Language Socialization
- Rebecca Rogers: [Critical Discourse Analysis in Education](#). In Volume: Discourse and Education
- Stanton Wortham: [Linguistic Anthropology of Education](#). In Volume: Discourse and Education

## References

- Bakhtin, M. M. (1981). The dialogic imagination: Four essays. In M. Holquist (Ed.), (trans: Emerson, C., & Holquist, M.). Austin: University of Texas Press.
- Bloommaert, J. (2013). *Ethnography, superdiversity and linguistic landscapes: Chronicles of complexity*. Bristol: Multilingual Matters.
- Bloome, D., Carter, S. P., Christian, B. M., & Otto, S. (2004). *Discourse analysis and the study of classroom language and literacy events: A microethnographic perspective*. New York: Routledge.
- Cazden, C. (1988). *Classroom discourse: The language of teaching and learning*. Portsmouth: Heinemann.
- Cazden, C., John, V., & Hymes, D. (Eds.). (1972). *Functions of language in the classroom*. New York: Teachers College Press.
- Clandinin, D. J. (2013). *Engaging in narrative inquiry*. San Francisco: West Coast Press.
- Clandinin, D. J., & Connelly, F. M. (2004). *Narrative inquiry: Experience and the story in qualitative research*. San Francisco: Jossey-Bass.
- de Freitas, E., & Sinclair, N. (2014). *Mathematics and the body: Entanglements in the classroom*. New York: Cambridge University Press.
- Erickson, F. (1982). Classroom discourse as improvisation: Relationships between academic task structure and social participation structure in lessons. In L. C. Wilkinson (Ed.), *Communicating in the classroom* (pp. 153–181). New York: Academic.
- Gee, J. P. (2014a). *An introduction to discourse analysis: Theory and method* (4th ed.). New York: Routledge.
- Gee, J. P. (2014b). *How to do discourse analysis: A toolkit* (2nd ed.). New York: Routledge.
- Gee, J. P. (2014c). *Unified discourse analysis: Language, reality, virtual worlds and video games*. New York: Routledge.
- Goffman, E. (1959). *The presentation of self in everyday life*. New York: Anchor Books.
- Goffman, E. (1981). *Forms of talk* (pp. 124–159). Philadelphia: University of Pennsylvania Press.
- Goodwin, C., & Duranti, A. (1992). Rethinking context: An introduction. In C. Goodwin & A. Duranti (Eds.), *Rethinking context: Language as an interactive phenomenon* (pp. 1–42). New York: Cambridge University Press.
- Green, J., & Dixon, C. (1993). Talking knowledge into being: Discursive and social practices in classrooms. *Linguistics and Education*, 5(3–4), 231–239.
- Gumperz, J. (1982). *Discourse strategies*. New York: Cambridge University Press.
- Halliday, M. A. K. (1973). *Explorations in the functions of language*. London: Edward Arnold.
- Heath, S. B. (1983). *Ways with words: Language, life, and work in communities and classrooms*. New York: Cambridge University Press.
- Hymes, D. (1974). *Foundations in sociolinguistics: An ethnographic approach*. Philadelphia: University of Pennsylvania Press.
- Jewitt, C. (2008). Multimodality and literacy in school classrooms. *Review of Research in Education*, 32, 241–267.
- Jewitt, C. (2009). *The Routledge handbook of multimodal analysis*. New York: Routledge.
- Jewitt, C., & Jones, K. (2007). Multimodal discourse analysis: The case of “ability” in UK secondary school English. In V. Bhatia, J. Flowerdew, & R. Jones (Eds.), *Advances in discourse studies* (pp. 149–160). New York: Routledge.
- Kress, G. (2013). Multimodal discourse analysis. In J. P. Gee & M. Handford (Eds.), *The Routledge handbook of discourse analysis* (pp. 35–50). New York: Routledge.
- Kress, G., & van Leeuwen, T. (2001). *Multimodal discourse: The modes and media of contemporary communication*. London: Edward Arnold.
- Lewis, C., & Tierney, J. D. (2013). Mobilizing emotion in an urban classroom: Producing identities and transforming signs in a race-related discussion. *Linguistics and Education*, 24(3), 289–304.
- Mehan, H. (1979). *Learning lessons: Social organization in the classroom*. Cambridge: Harvard University Press.

- Michaels, S. (1981). Sharing time: Children's narrative styles and differential access to literacy. *Language in Society*, 10(3), 423–442.
- Morgan, M. (2009). *The real hiphop: Battling for knowledge, power, and respect in the LA underground*. Durham: Duke University Press.
- Orellana, M. (1999). Good guys and “bad” girls: Identity construction by Latina and Latino student writers. In M. Bucholtz, A. C. Liang, & L. A. Sutton (Eds.), *Reinventing identities: The gendered self in discourse* (pp. 64–82). New York: Oxford University Press.
- Rampton, B. (2008). *Language in late modernity: Interaction in an urban school*. New York: Cambridge University Press.
- Rex, L., & Juzwik, M. (Eds.). (2011). *Narrative discourse analysis for teacher educators: Managing cultural differences in classrooms*. New York: Hampton Press.
- Rex, L., & Schiller, L. (2009). *Using discourse analysis to improve classroom interaction*. New York: Routledge.
- Rogers, R. (Ed.). (2011). *An introduction to critical discourse analysis in education* (2nd ed.). Mahwah: Lawrence Erlbaum Associates.
- Rogers, R., & Schaenen, I. (2014). Critical discourse analysis in literacy education: A review of the literature. *Reading Research Quarterly*, 49(1), 121–143.
- Rymes, B. (2009). *Classroom discourse analysis: A tool for critical reflection*. New York: Hampton Press.
- Rymes, B. (2016). *Classroom discourse analysis: A tool for critical reflection* (2nd ed.). New York: Routledge.
- Sacks, H., Schegloff, E., & Jefferson, G. (1974). A simplest systematics for the organization of turn-taking for conversation. *Language*, 50, 696–735.
- Scollon, R. (1999). Mediated discourse and social interaction. *Research on Language and Social Interaction*, 32, 149–154.
- Scollon, S. W., & de Saint-Georges, I. (2013). Mediated discourse analysis. In J. P. Gee & M. Handford (Eds.), *The Routledge handbook of discourse analysis* (pp. 66–78). New York: Routledge.
- Wohlwend, K. E. (2009). Damsels in discourse: Girls consuming and producing identity texts through Disney princess play. *Reading Research Quarterly*, 44(1), 57–83.
- Wohlwend, K. E. (2013). Mediated discourse analysis: Tracking discourse in action. In P. Albers, T. Holbrook, & A. Flint (Eds.), *New methods of literacy research* (pp. 56–69). New York: Routledge.
- Woolfitt, R. (2005). *Conversation analysis and discourse analysis: A comparative and critical introduction*. London: Sage.
- Wortham, S., & Rymes, B. (Eds.). (2003). *Linguistic anthropology of education*. Westport: Praeger.

---

# Researching Multimodality in Language and Education

Jennifer Rowsell and Diane R. Collier

---

## Abstract

Multimodality has emerged out of relative obscurity over the past two decades as a term that has purchase in language and literacy research, theory, and practice. This chapter is concerned with research methods and approaches to the study of multimodality in language and education. Origins, early developments, and current uses of multimodality are discussed. Research methods that examine multimodal meaning-making operate across varied contexts and use diverse heuristics and research tools.

Multimodality explains communication as a combination of modes of representation and expression within text designs (with the term *text* referring to communicative acts beyond but including print or writing). The various multiple modes of expression can be visual (e.g., drawing, painting, video), print (e.g., books, newspapers, environmental print), gestural (e.g., miming, pointing, acting out), dramatic (e.g., role-playing, improvisation, formal acting), and oral (e.g., informal talk, public speaking) modes (Kress Multimodality. In: Cope B, Kalantzis M (eds) *Multiliteracies: literacy learning and the design of social futures*. Routledge, London, pp 182–202, 2000; Stein TESOL Q 32(3): 517–528, 1998). Kress often stands as a harbinger of multimodality with his theory and writings over the years, but this field can be traced to earlier theorists such as Halliday (with whom Kress studied).

Major research trends in response to early developments have emphasized design, digital and visual literacies, juxtapositions of home and school literacies,

---

J. Rowsell (✉)

Department of Teacher Education, Canada Research Chair in Multiliteracies Brock University,  
Ontario, ON, Canada

e-mail: [jrowsell@brocku.ca](mailto:jrowsell@brocku.ca)

D.R. Collier (✉)

Department of Teacher Education, Brock University, Saint Catharines, ON, Canada

e-mail: [diane.collier@brocku.ca](mailto:diane.collier@brocku.ca)

and interests in material culture, to name a few. Current explorations of embodiment, *Deleuzian* approaches, material culture, cultural geography, and gamification have resulted in innovative research methods. Challenges of multimodal applications to educational contexts that move beyond representation and that address earlier claims and issues of equity and social justice are described.

### Keywords

Multimodality • Research • Multiliteracies

### Contents

Introduction .....	312
Early Developments: Text-Centric Semiotics → Social Semiotics .....	313
Major Contributions: Social Semiotics → Multimodal Literacies, Context, and Identities ...	314
Kress: Nuancing Social Semiotics → Multimodality .....	315
Siegel: Transmediation as Movement Across Modes .....	315
The New London Group: A Pedagogy of Multiliteracies .....	315
Early Responses to Siegel, Kress, and the New London Group .....	316
Stein: Multiple Modes and Equity Research .....	316
Ethnographic Research on Everyday Literacies .....	317
Researching Up Close Across Time and Space .....	317
New Research Methods: Borrowing Across Fields .....	317
Works in Progress: Transdisciplinary Moves .....	318
Co-curation .....	318
Emotions and Embodiment .....	318
Aesthetic Perspectives .....	319
Material Cultural Perspectives .....	319
Translingual Perspectives .....	319
Immersive and Virtual World Perspectives .....	319
Mobility Perspectives .....	320
Problems and Difficulties .....	320
Conflation of Design Literacies, Digital Literacies, and Visual Literacies with Multimodality .....	320
Retaining Complexity of Multimodally: How to Capture Multimodal Data .....	320
Spaces Between Modes and Nonlinear Representation .....	321
Challenges of Application .....	321
Future Directions .....	322
Cross-References .....	323
Related Articles in the Encyclopedia of Language and Education .....	323
References .....	323

### Introduction

Multimodality has emerged out of relative obscurity over the past two decades as a term that has purchase in language and literacy research, theory, and practice. This chapter is concerned with research methods and approaches to the study of multimodality in language and education. Origins, early developments, and current uses of multimodality are discussed. Research methods that examine multimodal meaning-making operate across varied contexts and use diverse heuristics and research tools.

Multimodality explains communication as a combination of modes of representation and expression within text designs (with the term *text* referring to communicative acts beyond but including print or writing). The various multiple modes of expression can be visual (e.g., drawing, painting, video), print (e.g., books, newspapers, environmental print), gestural (e.g., miming, pointing, acting out), dramatic (e.g., role-playing, improvisation, formal acting), and oral (e.g., informal talk, public speaking) modes (Kress 2000; Stein 1998). Kress often stands as a harbinger of multimodality with his theory and writings over the years, but this field can be traced to earlier theorists such as Halliday (with whom Kress studied).

Major research trends in response to early developments have emphasized design, digital and visual literacies, juxtapositions of home and school literacies, and interests in material culture, to name a few. Current explorations of embodiment, *Deleuzian* approaches, material culture, cultural geography, and gamification have resulted in innovative research methods. Challenges of multimodal applications to educational contexts that move beyond representation and that address earlier claims and issues of equity and social justice are described.

---

### Early Developments: Text-Centric Semiotics → Social Semiotics

Although the term *multimodality* became more prominent at the turn of the twenty-first century, language and literacy educators and researchers have been interested in other modes, besides print, since the 1970s (e.g., Clay 1975) and the 1980s (e.g., Dyson 1982). In practice, the term multimodal is used often when talking about visual or design literacies, digital literacies, or nonlinguistic modes alongside other modes. Print texts can also be considered multimodal if one considers elements such as layout, and font, as well as tactile features of a particular text, for example. Multimodality is not new although the ways in which texts are viewed as multimodal and the ways that non-print texts are valued are shifting.

The roots of multimodality in education are most closely connected to early theorists in semiotics, starting with Saussure (1959) and Peirce (1977), linguists who explored how signs are used to convey meaning and then more fully developed by Halliday, who presented a social understanding of semiotics. Semiotics works on the principle that anything can be a sign, as long as one derives meaning from it. Theorists working within a semiotic frame view language as an idealized and abstract system (Peirce 1977; Saussure 1959). Peirce and Saussure, two key semioticians, both recognized that semiosis does not happen in isolation. Saussure developed a formalized approach to semiotics that described how signs have meaning relationships to each other. Peirce, on the other hand, believed that people use semiotic resources at hand to communicate. One of Peirce's well-known phrases is "we think only in signs." Along with Saussure, he discussed the signifier as the form and the signified as the concept one derives from the form. In multimodal parlance, the signifier is the material and mode and the signified is how meaning is made. Both theories are complex and this summary does not do them justice; nonetheless, on the whole, what both semioticians foreground in their work is an

opening up of what text is or can be, and the germs of their theories grew into multimodality.

Like linguistics, semiotics has a technical, and, at times, rigid, grammar. Theorists like Halliday working within a semiotic framework felt constrained by the rigidity of a grammar and this is reflected in his work. In the 1970s, Halliday developed *social* semiotics and how language is socially negotiated and socially constructed. While moving the field of semiotics into the social, he wrote that meaning arises from social interaction and is made through a “dynamic process of sign making” (Halliday 1985). With this social turn, Halliday showed how the making of signs and sense making through texts is inherently human and individuals use and make meaning from materials and modes within contexts.

In his writings, Halliday discusses how individuals make choices from different modes of representation and expression based on the situation and the audience, and through this reasoning he developed metafunctions. Halliday refers to metafunctions as fundamental properties of all signs. There are three metafunctions that constitute texts: (1) an ideational metafunction that refers to the ideas or concepts that represent meanings in a text/sign; (2) an interpersonal metafunction that refers to the target audience, the intended view to which the sign speaks; and (3) a textual metafunction that refers to the text’s design, to the physical, material choices that constitute the face of the ideas presented to the text’s audience. Halliday’s language of description provided more granular ways of describing meaning-making and showed how pivotal social mediation and subjective choices are in sign-making. Studying with Halliday, Kress then moved the field of social semiotics into multimodality as an accepted term within educational theory and practice. Some years later, Kress continued to build on Halliday’s ideas when he talked about sign-making as a metaphor for the ways in which meanings are multiplied. By the mid-1990s, multimodality became more prominent within literacy education and Kress and Siegel stood out as key multimodal theorists.

---

### **Major Contributions: Social Semiotics → Multimodal Literacies, Context, and Identities**

In the 1980s and 1990s, when multimodality was becoming more central in language and literacy, several conceptual strands were present in the field: the elaboration of multimodality by Kress and Hodge and by Kress and Van Leeuwen; Siegel’s description of transmediation, meaning-making across sign systems; the formation of the New London Group and the publication of the pedagogy of multiliteracies manifesto; and various responses to the New London Group and others that were manifested through further research and translated into educational practice. During this period, which represented a social turn in literacy and education research, context and identities became more relevant. In this section, major foci of multimodal research, as well as new approaches to researching multimodality, are discussed.



## **Kress: Nuancing Social Semiotics → Multimodality**

In the late 1980s, Hodge and Kress (1988) elaborated on the intricacies of social semiotics as a more nuanced way of regarding communication. While accounting for how modes of communication are actually used, Hodge and Kress developed flexible terms and concepts for ways that people used different materials and invested parts of themselves in their text making. Across contexts and situations, individuals choose which modes to privilege. Kress and Hodge opened up ways for educational researchers to think about subjective and social mediation of content.

Kress built on these ideas when he talked about sign-making as a metaphor for the ways that meanings are multiplied in texts. Offering quite radical (for the time) conceptions of meaning-making, such as motivated signs, Kress maintained that when a child or meaning-maker more generally composes a text, the text design and content are driven by the interests and the motivations of the sign-maker. If the sign-maker draws four circles to represent a car, then that is how the sign-maker sees the text and, by extension, this text is a window into their subjectivities. Kress used terms such as *affordances* and *constraints* and underscored the importance of affect and synesthesia as fundamental to how people design and “read” texts.

## **Siegel: Transmediation as Movement Across Modes**

Siegel (1995), also starting with Peirce and Saussure, and building on Halliday, focused early on the generative possibilities when moving across modes (i.e. from writing to drawing). She relied heavily on Peirce’s understanding of any sign use as the expansion of meaning and elucidated the organizational rules of different sign systems. One of her greatest contributions to the field has been her ability to explain and illustrate how meaning-makers, particularly children, move across two or more sign systems (e.g., from words to images and then to gesture) and, importantly, how meaning-makers invent relationships between modes which enriches their understandings). Siegel argued that children use these generative potentials more fully as they move more easily across modes in their early play, until they learn how to work within more valued modes (such as print). She connects the generative potential of transmediation, or cross-modal movement, with the turn, in educational arenas, toward inquiry rather than transmission models of formalized learning. By complicating and nuancing meaning-making in this way, she demonstrated how young children represent agency in their learning.

## **The New London Group: A Pedagogy of Multiliteracies**

In 1994, The New London Group formed to build an agenda for transformation of literacy practice, key components of which were the need to change what counts as literacy and an acknowledgment of the multimodal nature of literacy practice. The pedagogy of multiliteracies was intended to (1) shift what is counted as literacy and

(2) acknowledge the multimodality of literacy practices. Kress had the longest history of theorizing multimodality and design dating back to his early social semiotic work with Hodge (Hodge and Kress 1988) and then on his own as well as with Kress and Van Leeuwen (2006). Within this work, children's multimodal texts and the meanings constructed through these texts challenged the dominance and authority of print above other modes. The New London Group (1996) pushed for use of their pedagogical manifesto to reframe and expand literacy – and the importance of multimodality as a primary idea – in both research and educational contexts. In the wake of this landmark event and the edited collection that resulted from it, the multiliteracies framework has been applied across varied contexts and learning spaces to research language and literacy practices and to broaden definitions of communicative competence.

### **Early Responses to Siegel, Kress, and the New London Group**

In response to the early work of Kress, the New London Group, and Siegel, many others took up the value of multimodal perspectives as foci for their research and for pedagogical purposes. Much of Siegel's theorizing derived from detailed observational work watching young learners make meaning. By 2000, other researchers began to operationalize such terms and concepts as transmodal work, the motivated sign, and affordances and constraints of modes across different contexts.

### **Stein: Multiple Modes and Equity Research**

The New London Group argued from a Freirean perspective for the need to critique the mainstream or popular face of education and provide access to learning for more people, in more ways. Interest in non-print modes, as well as recognition of the multiple modes represented through many textual forms, often connected to an interest in equity and the potential for an expanded understanding of literacy to allow for successful participation by more learners. A communicative ensemble evokes how the elements of an orchestra work to produce a performed piece of music. Stein argued that the consideration of multiple modes, especially those that are not based in language such as drawing and gesture, renders visible ideas, feelings, and meanings not as easily conveyed directly through language. Stein moved the language of multimodality into social justice work by observing how young children in South Africa moved across contexts from home to school to out in the community and built on their own awareness and backgrounds to make signs and how these untapped, sophisticated understandings can be built upon in school (Stein 1998). Other researchers describe the multimodality of communicative texts in terms such as bricolage, assemblage, and composition (e.g., Wohlwend 2009). All argued that when multimodal modes of expression come together, they create something more than the sum of their parts.

## Ethnographic Research on Everyday Literacies

Researchers also began to investigate more fully how multimodality might be conceived outside of formal educational settings, across home and school contexts. Researchers like Pahl (2007) spent extended periods of time in homes, out in the community, and in schools observing, writing field notes, and, perhaps most importantly, collecting artifacts that they would analyze and lift out the choices made during production and the larger ideologies, values, and beliefs that these artifacts signal.

Although Barton and Hamilton's (1998) 3-year ethnography of a town in the northwest of England may not identify as multimodal, their research methods drew on social semiotics and multimodal meaning-making. *Local Literacies* drew from a large corpus of data that were photographic, written texts, diagrams, signage, and their interpretative framework in the book drew significantly on the visual communication of everyday texts. Focusing on the social practices of everyday life took an anthropological gaze on the texts of everyday life. They sorted photographs into categories of events and practices. Using an artifactual, descriptive approach, they validated a diversity of everyday literacy practices.

## Researching Up Close Across Time and Space

In many multimodal research endeavors, there were attempts to look at data in a granular way, and critical discourse analysis was often used. Using one form of critical discourse analysis, Scollon and Scollon (2003) applied the principles of social semiotics to their research method. They researched semiotics within particular spaces and how individuals move through semiotic systems while constantly reading and interpreting texts across spatial landscapes, albeit in a naturalized, tacit way. Similarly, Lemke (2000) supplemented multimodal theory by theorizing of literacy practices through *timescales*. Lemke explained that objects or artifacts carry with them longer and shorter timescales. An everyday object, like a household knife, does not carry the longer timescale and power that a samurai sword carries because the samurai sword has a much longer history and heritage. As Lemke described, "the material characteristics of the object also function as *signs* for an interpreting system of meanings that belong to processes on a very different timescale than that of the event in which the interpreting process is taking place" (p. 281, emphasis in original). Lemke's timescales offered researchers a method to analyze the significance of everyday objects within an individual's learning trajectory.

## New Research Methods: Borrowing Across Fields

Research in the area of multimodality has been largely qualitative, often ethnographic, and engaged in close-up study of phenomenon. Certainly ethnographic

and qualitative methods have often included the collection of visual or material data in the forms of artifacts such as drawings, photographs, and objects. The primacy of data collected in visual, auditory, or video forms has been highlighted through multimodal research. Regardless of the breadth of qualitative research, especially that following an anthropological tradition, the transcripts of speech from observation or from interviews have been the most cited and analyzed mode of data.

---

## **Works in Progress: Transdisciplinary Moves**

At present, the study of multimodality requires the nimble use of conventional research tools and methods but also engages some in a quest for new tools and methods of analysis. Varied approaches to multimodality have evolved out of efforts to research across contexts and combine a multimodal interpretative framework with other theoretical perspectives, fields, and disciplines. An example of this approach is exemplified in a collection by Pahl and Rowsell (2006), featuring international research that combined multimodality with New Literacy Studies and anthropological perspectives to illustrate complexities at play during meaning-making and a nuanced blending of theoretical traditions. Below are more examples of these emerging approaches.

### **Co-curation**

Coproduction of research and analysis alongside research participants has become prominent in the early twenty-first century, alongside an increased interest in the roles of art galleries and museum in multimodal learning experiences. Multimodal, environmental installations provoke learners (e.g., Hackett 2014), and those who build upon “children’s voice” research, originating primarily in the UK, have engaged in partnerships with participants and community members in formal and informal learning spaces (e.g., Jones 2014).

### **Emotions and Embodiment**

More recently, there has been a push with for research that emphasizes the embodied and affective nature of multimodal meaning-making (e.g., Leander and Boldt 2013). Lewis and Tierney (2013) focused on how emotive interactions in race-related discussions were mediated by texts and visuals in an ethnically diverse urban school. They analyze how emotion is often separated from the mind and excluded from disciplines like semiotics, linguistics, and multimodal research, perhaps because emotion is laden with felt sensibilities and intangible aspects as feelings, beliefs, and embodiment.

## **Aesthetic Perspectives**

Many semiotic and linguistic accounts of aesthetics have focused on the arts and artistic appreciation. Multimodal theorists have incorporated theories of aesthetics into their multimodal research in order to soften design grammar and to reflect on alternative perspectives on how aesthetic features signal agency.

## **Material Cultural Perspectives**

Researchers of material culture have been preoccupied with how we interact with objects in our environments and how children engage in playful literacy work with toys (Wohlwend 2009). This multimodal literacy research values children's contributions and expertise in their own explorations, and reflexive, sometimes parodic, multimodal play (Collier 2015). Brandt and Clinton (2002), using actor-network theory (Latour 2005), traced the movement of and relations to nonhuman actors (i.e., a book) in networks, looked at local-global connections, and argued that a "transcontextual" (p. 343) understanding of local literacies may not adequately account for all of the literacy ideas and objects with which we engage.

## **Translingual Perspectives**

Globalization and its impact on communication and multimodality have been introduced by theorists like Canagarajah (2013) who use concepts such as *translingual practice* to highlight the point that traditional terms such as bilingual literacy or multilingual literacy create boundaries around language proficiency and cultural practices. Individuals usually draw on a range of genres, registers, dialects, and styles that render the concept of monolingual outdated. Researchers working across language education and multimodality have used multimodality to defy the mononature of language practices and to illustrate how multiple and multimodal language and literacy practices are (e.g., Kenner 2004).

## **Immersive and Virtual World Perspectives**

Multimodality has lent itself to research in digital worlds (Marsh 2005) because digital worlds are fundamentally multimodal. Gee (2006) has been pivotal in highlighting the strength of video games in fostering new literacy practices. Indeed, research on learning in virtual worlds draws significantly on the role of different modes in guiding thinking and problem-solving practices. Positioning the game controls as nonhuman participants, DeCastell et al. (2008) have critiqued assumptions about rule following and gendered assumptions of video game play. They used a form of microanalysis of video segments that slow down the passage of time and

embodied participation. Within online and immersive spaces, gendered, linguistic, and cultural identities can be modified or reconfigured with different impacts and effects that involve the coming together of modes.

## **Mobility Perspectives**

Coupling theories of mobility and actor-network theory (Latour 2005) with multimodality allows researchers to build in spatial theory (Leander and Boldt 2013) into their interpretations of modal learning across different contexts. Indeed, the concept of semiotic mobility resonates with Deleuze and Guattari's (1987) challenge to static and logocentric forms of thinking and meaning-making through their concept of the "rhizome." Their delineation of the rhizome and of rhizomic movement allows for thinking about movement from one mode to another or transmodal work. This approach complicates multimodality because of the multiple and unpredictable ways in which individuals produce and read texts across sites.

---

## **Problems and Difficulties**

### **Conflation of Design Literacies, Digital Literacies, and Visual Literacies with Multimodality**

The primary challenge of multimodal approaches and research has been to tease apart design and multimodality, which have been used in almost synonymous ways. *Reading Images* by Kress and Van Leeuwen (2006) has contributed greatly to the reception and interpretation of and to the focus of researchers and educators on design. The term "design" was integral to the pedagogies of multiliteracies manifesto put forth by the New London Group who were interested in the digital as a place of expanding conceptualizations of literacy. However, digital and design literacies (Sheridan and Rowsell 2010) have sometimes been coopted in mechanistic or superficial. Design is only one part of the multiliteracies pedagogy and has been a focus because it naturally coexists with the desire and need to understand, interpret, and value the visual, in formal classroom settings and in the online world. Design literacies that follow Kress and Van Leeuwen's grammar have a Western focus and have not always been helpful for visuals produced in non-Western settings.

### **Retaining Complexity of Multimodally: How to Capture Multimodal Data**

Another challenge for multimodal research is how to retain the complexity of multimodality and both the ways in which modes come together and the affordances of modes singly. Bazalgette and Buckingham (2013) argue that multimodality has

been used to dichotomize print and non-print texts. They also argue that multimodality's inherent complexity has been oversimplified in its translation from research to practice and that the importance of interaction between modes is not captured by current research and practice. The ways in which multimodal data is generated, captured, and analyzed in ways that represent its multimodal nature are still a challenge. For example, with multifaceted, multimodal approaches, researchers are challenged to situate physical movement of an individual alongside swiftly changed web-based images. Of particular concern is how one can analyze data that is collected in asynchronous or nonlinear ways, and then, further, how to present multimodal data when reporting findings, where even illustrations or other non-print representations are still resisted in established publications.

### **Spaces Between Modes and Nonlinear Representation**

Connected to concerns with process and the “how” of multimodality text making, Siegel and Panofsky (2009) argued that what is absent from semiotic consideration of multimodality is an “understanding of what people make of the space between multiple modes” (p. 101). In response to this concern, they turned to sociocultural theory to provide meanings beyond multimodal analysis (or an examination of “site of appearance,” “display,” “narrative,” and “genre”) that might account for texts’ origins as well as “what human beings do as organized in activities that are practiced by social groups” (p. 105). Although one may often consider texts as finished products, such as a published novel, a publicly hung painting, or a choreographed dance work performed for an audience, here texts-in-process or drafts are considered as worthy of examination for the influences that are rendered invisible when one looks only at final products. Following Deleuze and Guattari’s (1987) rhizomatic, nonrepresentational theory of how subjectivities and literacy moments are produced in nonlinear ways, Leander and Boldt (2013) have argued for an understanding of meaning-making that is grounded in diffuse and embodied experiences of the world. This unbounded nature of communicative practice can include multilingual and digital forms, often unrecognized within traditional governance structures, but recognized within contemporary society and local spaces. The influence of cultural geographers (e.g., Massey 2005) is seen in the ways that literacies are presented in ways that stretching across the fluid and changing elements of time and space.

### **Challenges of Application**

In many areas of multimodal literacy and multiliteracies research, the hopes for equitable and transformed educational practice have not been fully realized. Critiques of multimodal work can be, at the same time, critiques of schooling (Jacobs 2013/2014), and the entanglement of schooling and multimodality continues.

The New London Group's manifesto and its shortcomings in practice constitute a call to revisit and highlight the commitment to equity originally expressed and the potential for multimodal literacies to address these issues.

---

## Future Directions

Multimodality has widespread hold as a way of both understanding and expanding literacies, how meaning is communicated and created through ways of interacting in contemporary times. As with all fields of research and inquiry, the landscape of multimodality is shifting. Based on its history and present directions, it is likely that certain areas will come into greater focus and clarity. Based on this audit of the field to date, the following pathways are perceived as future foci for multimodal research: a return to the New London Group (1996) manifesto to build on these original ideas – the “twin goals of access and critical engagement” (p. 96); more work on social justice and equity studies across international contexts; more transdisciplinary research drilling deeply into language and linguistic and cultural diversity; an emphasis on big data and multimodality on Twitter and other large repositories of quantitative, visual, modally complex data; and research on wearable computers and gaming heuristics and epistemologies (e.g., Minecraft).

Future understandings of multimodality need to continue to be grounded in both offline and online worlds (without dichotomizing these), should consider the affordance of modalities (e.g., visual versus auditory modes), and also are called to explore in finer ways the complexity of modes that come together in multimodal literacy moments, events, and representations. The identities (or subjectivities) of multimodally literate beings are grounded in a wide range of overlapping and changing social investments and are the result of embodied, sensory, and diverse affects and effects.

One example of a generative vein of inquiry for future multimodal research is exemplified by Burnett's (2015) argument that today children, adolescents, and teenagers move in and out of physical spaces and nonphysical, virtual spaces that shape their understandings about the worlds. In this work, she contends that literacies which relate to physically present objects and texts coexist and seep into more immaterial literacies which are materially absent and intangible but nevertheless integral to meaning-making such as memories, feelings, and even virtual worlds. Her approach decenters mechanistic work on digital environments as a panacea or as a tool, and through data from her research and other research, Burnett maintains how complicated and rhizomatic moving between online and offline worlds can be.

When working with multimodality, and a multiliteracies perspective, these tensions are inevitable and can be productive. Additionally, a view of multimodality that keeps critical perspectives, equity, and social justice at the forefront is one that can potentially lead to educational change and considers how multimodal perspectives allow for one to see what is happening differently and for one to recognize and value the potentialities of various modes and modal compositions.



---

## Cross-References

- ▶ [Arts-Based Approaches to Inquiry in Language Education](#)
- ▶ [Discourse Analysis in Educational Research](#)
- ▶ [Researching Timescales in Language and Education](#)
- ▶ [Visual Methods in Researching Language Practices and Language Learning: Looking at, Seeing, and Designing Language](#)

---

## Related Articles in the Encyclopedia of Language and Education

- Carey Jewitt: [Multimodal Discourses Across the Curriculum](#). In Volume: Language, and Technology
- Kate H Pahl: [Language Socialization and Multimodality in Multilingual Urban Homes](#). In Volume: Language Socialization

---

## References

- Barton, D., & Hamilton, M. (1998). *Local literacies: Reading and writing in one community*. London: Routledge.
- Bazalgette, C., & Buckingham, D. (2013). Literacy, media and multimodality: A critical response. *Literacy*, 2, 95–102.
- Brandt, D., & Clinton, K. (2002). Limits of the local: Expanding perspectives on literacy as a social practice. *Journal of Literacy Research*, 34(3), 337–356.
- Burnett, C. (2015). Immaterializing literacies. In J. Rowsell & K. Pahl (Eds.), *The Routledge handbook of literacy studies*. London: Routledge.
- Canagarajah, S. (2013). *Translingual practice: Global Englishes and cosmopolitan relations*. London: Routledge.
- Clay, M. (1975). *What did I write?: Beginning writing behaviour*. Portsmouth: Heinemann.
- Collier, D. R. (2015). “I’m just trying to be tough, okay”: Masculine performances of everyday practices. *Journal of Early Childhood Literacy*, 15(2), 203–226.
- De Castell, S., Boschman, L., & Jensen, J. (2008). In and out of control: Learning games differently. *Loading. . .*, 2(3), 1–16.
- Deleuze, G., & Guattari, F. (1987). *A thousand plateaus: Capitalism and schizophrenia* (trans: Massumi B.). Minneapolis: University of Minnesota Press.
- Dyson, A. H. (1982). The emergence of visible language: Interrelationships between drawing and early writing. *Visible Language*, 16(4), 360–381.
- Gee, J. P. (2006). What is literacy? In P. I. Vandenberg, S. I. Hum, & J. I. Clary-Lemon (Eds.), *Relations, locations, positions: Composition theory for writing teachers* (pp. 29–39). Urbana: National Council of Teachers of English.
- Hackett, A. (2014). Zigging and zooming all over the place: Young children’s meaning making and movement in the museum. *Journal of Early Childhood Literacy*, 14(1), 5–27.
- Halliday, M. (1985). *An introduction to functional grammar*. London: Edward Arnold.
- Hodge, R., & Kress, G. (1988). *Social semiotics*. Ithaca: Cornell University Press.
- Hull, G., & Nelson, M. E. (2005). Locating the semiotic power of multimodality. *Written Communication*, 22(2), 224–261.
- Jacobs, G. E. (2013/2014). Reimagining multiliteracies: A response to Leander and Boldt. *Journal of Adolescent & Adult Literacy*, 57, 270–273.

- Jones, S. (2014, Dec). Attempting to do no harm: Inquiring into embodied literacies of space in community-based research. Symposium presentation at annual meeting of Literacy Research Association, Marcos Island, Florida.
- Kenner, C. (2004). *Becoming biliterate: Young children learning different writing systems*. Stoke on Trent: Trentham Books.
- Kress, G. (2000). Multimodality. In B. Cope & M. Kalantzis (Eds.), *Multiliteracies: Literacy learning and the design of social futures* (pp. 182–202). London: Routledge.
- Kress, G. R., & Van Leeuwen, T. (2006). *Reading images: The grammar of visual design*. London: Routledge.
- Latour, B. (2005). *Like Halliday*. Oxford: Oxford University Press.
- Leander, K., & Boldt, G. (2013). Rereading “A pedagogy of multiliteracies”: Bodies, texts, and emergence. *Journal of Literacy Research*, 45, 22–46.
- Lenke, J. L. (2000). Across the scales of time: Artifacts, activities, and meanings in ecosocial systems. *Mind, Culture & Activity*, 7(4), 273–290.
- Lewis, C., & Tierney, J. D. (2013). Mobilizing emotion in an urban classroom: Producing identities and transforming signs in a race-related discussion. *Linguistics and Education*, 24, 289–304.
- Marsh, J. (2005). *Popular culture, new media, and digital literacy in early childhood*. New York: Routledge.
- Massey, D. (2005). *For space*. London: Sage.
- New London Group. (1996). A pedagogy of multiliteracies: Designing social futures. *Harvard Educational Review*, 66(1), 60–92.
- Pahl, K. (2007). Timescales and ethnography: Understanding a child’s meaning-making across three sites, a home, a classroom, and a family literacy class. *Ethnography and Education*, 2(2), 175–190.
- Pahl, K., & Rowsell, J. (2006). *Travel notes from the new literacy studies*. Clevedon: Multilingual Matters.
- Peirce, C. S. (1977). Semiotics and signification. In C. S. Hardwick (Ed.), *Semiotics and signification. The correspondence between Charles S. Peirce and Lady Victoria Welby*. Bloomington: Indiana University Press.
- Saussure, F. D. (1959). *Course in general linguistics* (trans: Baskin, W.). In C. Bally, A. Sechehaye, & A. Riedlinger (Eds.). New York: Philosophical Library.
- Scollon, R., & Scollon, S. K. (2003). *Discourses in place: Language in the material world*. London: Routledge.
- Sheridan-Rabideau, M. P., & Rowsell, J. (2010). *Design literacies: Learning and innovation in the digital age*. London: Routledge.
- Siegel, M. (1995). More than words: The generative power of transmediation for learning. *Canadian Journal of Education*, 20(4), 455–475.
- Siegel, M., & Panofsky, C. P. (2009). Designs for multimodality in literacy studies: Explorations in analysis. In K. M. Leander (Ed.), *58th yearbook of the national reading conference* (pp. 99–111). Oak Creek: National Reading Conference.
- Stein, P. (1998). Reconfiguring the past and the present: Performing literacy histories in a Johannesburg classroom. *TESOL Quarterly*, 32(3), 517–528.
- Wohlwend, K. E. (2009). Damsels in discourse: Girls consuming and producing identity texts through Disney princess play. *Reading Research Quarterly*, 44(1), 57–83.

---

# Researching Developing Discourses and Competences in Immersion Classrooms

Anne-Marie de Mejía

---

## Abstract

This chapter traces the development of research in immersion and in Content and Language Integrated Learning (CLIL) classrooms from their beginnings, when the emphasis was on program evaluation to current tendencies foregrounding pedagogical concerns, code-switching, multilingual perspectives, and sociocultural concerns. The main contribution section initially examines how ethnography came to be seen as an important means of researching classroom processes, teacher and student beliefs, as well as sociocultural and political factors. The results of studies carried out in Finland, the United States, Catalonia, Canada, Austria, Australia, Japan, Ireland, Colombia, and Paraguay are presented and discussed, particularly with respect to qualitative perspectives. Finally, in the section directed toward future tendencies, there is a discussion of studies focusing on bilingual and multilingual classroom discourse in immersion education and teacher training for practitioners working with young children. This chapter finishes by concluding that research on immersion and CLIL programs has greatly broadened in scope from its beginnings.

---

## Keywords

Immersion • CLIL • Ethnography • Code-switching • Immersion pedagogy

---

In the context of this chapter, the term “immersion” refers to the type of bilingual programs that originated in Canada in the 1960s. It does not cover the “dual” or “two-way immersion” modality, which has become popular recently in the United States with non-immersion students (de Courcy 1997).

A.-M. de Mejía (✉)

Facultad de Educación, Universidad de los Andes, Bogotá, Colombia

e-mail: [atruscot@uniandes.edu.co](mailto:atruscot@uniandes.edu.co); [annemariemejia@hotmail.com](mailto:annemariemejia@hotmail.com)

## Contents

Introduction .....	326
Early Developments .....	327
Major Contributions .....	328
Changing Perspectives: Calls for the Use of Ethnography .....	328
Researching Immersion Pedagogy .....	329
Investigating Teacher Beliefs and Practices .....	329
Emphasizing Learner Perspectives on Learning .....	331
Examining Sociocultural and Political Factors .....	331
Work in Progress .....	332
Language Acquisition and Development with L1 and L2 Student Populations .....	332
Language Learning in Relation to Literacy Development .....	333
Code-Switching and Classroom Language Use .....	333
Problems and Difficulties .....	334
Future Directions .....	335
Cross-References .....	336
Related Articles in the Encyclopedia of Language and Education .....	336
References .....	336

## Introduction

It has been 40 years since the beginning of the first experimental Canadian French immersion project in St Lambert, Montreal, in 1965 and the beginnings of research into this educational phenomenon. Today, there is a well-established and well-regarded research literature on immersion programs, both in Canada and in other parts of the world. Indeed, as Stern (1984) acknowledged, immersion is probably one of the most thoroughly investigated educational innovations of all times. In 1996, there was a further important development in the field, this time in Europe, with the emergence of Content and Language Integrated Learning (CLIL).

Over the past three decades, the type of research carried out in this field has changed direction considerably, both in relation to focus and methodological orientation. The growing internationalization of the immersion movement in the United States, in different European nations, in certain Asian countries such as Hong Kong and Japan, and in Australia has led to the recognition of immersion as a world phenomenon. Furthermore, the differing conceptualizations of immersion programs as foreign language development, as minority language provision for majority language students, as language revival, as language support, and as contact with a language of power have meant that increasingly diverse research interests and concerns are being addressed in this field. Although the developments in research on CLIL are more recent, there have also been interesting tendencies related to classroom interaction and language use.

## Early Developments

The early Canadian immersion programs were conceived, right from the start, as integrally bound up with a process of systematic evaluation and research. The focus was on assessment of their impact on the linguistic, intellectual, and attitudinal development of the children involved in the study (Lambert and Tucker 1972). Thus, the actual lines of inquiry involved in this type of extensively funded policy-driven research were largely restricted initially to a focus on educational outcomes, comparing immersion with non-immersion students.

This has been explicitly recognized by Lapkin and Swain (1984) and justified by the perceived need to demonstrate to policy makers that immersion was indeed a viable educational alternative and to reassure Anglophone parents that their children would not suffer either academically or in respect to their English language proficiency. It is interesting to note in this respect that Marsh and Frigols Martin (2013) also identify emphasis on language learning within CLIL as a predominant initial concern for research, while Ruiz de Zarobe (2013) maintains “most. . .research has focused on learning outcomes, looking mainly at the different linguistic area and competences . . . [and] content learning outcomes” (p. 236).

The performance of immersion and non-immersion students was compared initially in three main areas: (1) the maintenance and development of students’ first language (L1) and second language (L2), (2) students’ academic achievement, and (3) the attitudes of both learners and their parents toward Canadian Francophones. Overall, the results of these assessments were positive in linguistic and in academic terms. The students’ L1 did not suffer. Student proficiency in their comprehension of French (listening and reading) was seen to be approaching “native speaker standard” (Cummins and Swain 1986, p. 41), and there were no negative reports on academic achievement levels. However, while immersion students’ production levels of spoken and written French were found to be higher than results from the regular program, these were judged to be considerably lower than their comprehension skills. These early findings have also been replicated in later studies carried out in different immersion contexts (Genesee 2004).

The early research on change in participants’ attitudes was less conclusive. Lambert and Tucker (1972) found little difference in students’ perceptions toward Canadian Francophones as a result of the St Lambert program, while Lapkin and Swain (1984) found some evidence of broader perspectives toward cultural and linguistic diversity among immersion students in comparison to their non-immersion counterparts. In this respect, Heller (1990) maintains that the general lack of opportunity for the development of intergroup relationships between Francophones and Anglophones outside the school context is an important factor in accounting for the maintenance of stereotyped ethnic group images.

In relation to early research on CLIL, Navés and Victori (2010) have observed that due to the experimental nature of most of the programs implemented to date, the majority of research initiatives carried out have been exploratory in nature, generated by small-scale studies. This view has been echoed by Perez-Vidal (2013) in relation to the contradictory findings of CLIL research, attributable to methodological problems. These researchers recognize the need for a stricter control of variables, such as difference in starting ages, levels of exposure to CLIL, and different school contexts (public or private) to provide more methodologically controlled studies, which would in turn make it possible to make reliable comparisons in the future, while examining the longer-term effects of introducing CLIL instruction. The following section will illustrate the changing nature of research priorities both in immersion as well as CLIL contexts.

---

## Major Contributions

### Changing Perspectives: Calls for the Use of Ethnography

From the mid-1980s onward, the early, almost exclusive focus of immersion research on educational outcomes was modified. Stern (1990) situates this change of emphasis within the general debate on communicative language teaching that began in the late 1970s. He charts the concern of immersion researchers, such as Harley and Swain (1984), to identify positive and negative aspects of proficiency development in immersion students and to identify problem areas in the development of the proficiency of immersion classes. Thus, a significant strand of immersion research began to concentrate on aspects of classroom practices that were seen to be associated with the development of L2 proficiency.

There were also calls for immersion research to investigate the nature of classroom processes. In an influential article, Tardif and Weber (1987) suggested that attention to processes of classroom interaction and to the ethnography of communication in the immersion classroom might illuminate some of the language acquisition processes at work. This emphasis on ethnography as a fruitful methodological stance for immersion research was further endorsed by Heller in 1990. She advocated conducting ethnographic studies into the realities of the learners' communicative needs and the issues of intergroup relations within the wider Canadian sociopolitical context in order to solve such dilemmas as the "plateau" effect in L2 learning. Heller (1990) argued that:

since so few ethnographic studies of immersion (whether of the classroom or its school and community environment) are available, it is difficult to pinpoint further the communicative constraints of the French immersion classroom which may be blocking further development, or whether it is possible in fact to do anything further in an instructional context of any kind. (p. 76)

Responses to these calls for a change in research perspectives may be classified into four main currents or directions: (1) research into immersion pedagogy, (2) research into teacher beliefs and practices, (3) research into language learning processes, and

(4) research into sociocultural and political factors. All of these are examined briefly below. Some information about similar developments with regard to CLIL is also provided.

## Researching Immersion Pedagogy

In Finland, researchers at the University of Vaasa were particularly interested in examining some of the methodological assumptions underlying the newly established Swedish immersion programs, claiming that the adoption of immersion principles facilitated “a pedagogic-didactic renewal” (Laurén 1992, p. 21). As a result of his observation of teaching in the Swedish immersion program, Laurén proposed what he called “a two-phase-didactics for school” (p. 71) focusing initially on good pronunciation, automatized basic syntax, efficient communicative strategies, and positive attitudes toward language learning at school, to create a basic level of linguistic fluency at an early stage of language learning when prerequisites are optimal, which can later be expanded on and extended.

Another member of the Vaasa immersion research team, Vesterbacka (1991), was interested in the development of meaningful, ritualized routines in context-bound situations in immersion programs. The researcher examined young children’s language use in Swedish in relation to unchanging “routines” and partially changing “patterns.” Vesterbacka argued that these ritualized routines and patterns should be recognized as an important teaching and learning strategy at this level in immersion programs. She saw them as key means of providing confidence for young children to express themselves at an early stage in their bilingual development and to communicate with others in meaningful contexts in an effort to fulfill their basic needs as efficiently as possible.

This emphasis on pedagogy and classroom practices is mirrored by developments in research on CLIL that has endeavored to provide “descriptions and interpretations of the teaching and learning processes in a bottom-up rather than a top-down manner” (Smit and Dafourz 2012, p. 4). One example of this type of research is a case study carried out recently in Calabria, Italy (Grandinetti et al. 2013), which examined CLIL classroom activities designed to scaffold accessible content in science education and comprehensible language for students in their final year of high school. The authors came to the conclusion that the use of a foreign language for science education in fact facilitated students’ learning, as the learners’ limited linguistic competence obliged the teacher to move from a traditional teacher-centered approach to more student-led interactions.

## Investigating Teacher Beliefs and Practices

In the 1990s, increasing emphasis was given to process orientated work in immersion research in the United States, as evidenced by an in-depth study of teachers and teaching in two immersion programs, one French immersion and the other Spanish

immersion, in the Midwestern United States (Bernhardt 1992). This 2-year ethnographic research project focused on examining immersion teachers' beliefs and experiences as a way to understand how they approached their classroom practice. The researchers were also interested in examining "immersion teaching" as "a particular kind of teaching . . . not just language teaching" (Bernhardt 1992, p.3). There was thus, a new emphasis on pedagogical concerns rather than on the hitherto more widely discussed topics of the development and maintenance of student language proficiency independent of teaching and learning processes. The focus on teachers and classroom interaction, as seen through the eyes of principals, supervisors, and teacher trainers, and the detailed discussions of classroom routines and aspects of contextualized student-teacher interactions provided a fascinating glimpse of how teaching and learning are accomplished moment by moment in different foreign language immersion contexts.

The issue of how teachers view their classroom practice has been another interesting development in immersion research in Catalonia. Arnau (2000) situates this type of analysis within a "teacher thinking" approach, involving teachers reflecting on how they teach, either through narratives based on personal experience or collaborative reflection between teachers and researchers. A preliminary study based on this approach, carried out by the researcher in 2000, confirmed that the L2 principles that appear to guide teacher decisions are notions such as planned language, contextual contrast, comprehension, verbalization, access to interaction, and individualization. There is recognition that this type of reflection could result in curricular improvements in immersion settings.

The importance of pedagogical considerations in discussing classic issues in immersion literature relating to amount and intensity of student L2 language exposure on acquisition has been highlighted by Genesee (2004). He makes reference to "the nature and quality of classroom instruction" (p. 562) as a key variable in accounting for the level of student L2 achievement. He also foregrounds the need for future research into the effect of different pedagogical approaches in the promotion of L2 development, thus firmly linking the importance of differing approach to teaching and learning with language acquisition.

In a study carried out in Austria (Hüttner et al. 2013), the power of beliefs of both teachers and students regarding CLIL were examined. Through the use of semi-structured interviews of upper secondary school learners and their teachers, it was found that there was a very strong belief that learning in CLIL was characterized as "repeated practice" (p. 275) and that CLIL was seen as complementary to English as a foreign language (EFL) classes, with a focus on professional rather than general language use. However, in a rather surprising finding, the researchers discovered that none of the respondents "felt that any curricular aims in English were part of their CLIL classes" but rather that CLIL was "an extra provision of English practice made more enjoyable . . . by the absence of clear curricular aims" (p. 278). This was seen by the researchers as a change in affect by learners toward English and evidence of their increased self-confidence in their language learning processes.



## Emphasizing Learner Perspectives on Learning

There have also been studies carried out on language learning from a student's perspective. A recent qualitative study into the experiences of immersion learning of a group of second year students in a late Chinese immersion program at a university in Queensland (Australia) provides interesting insights into how learners view the ongoing process of learning a typologically and orthographically different language (de Courcy 2002). De Courcy found that the group of immersion students seemed to pass through four distinct phases in trying to make sense of classroom interaction with the first stage involving a heavy reliance on translation as a receptive strategy. This seems to be at odds with official immersion policy of a separation approach to language use based on Swain's (1983) principle of "bilingualism through monolingualism." Nevertheless, according to the empirical data analyzed, this seems to be a common initial strategy used by members of the Queensland Chinese immersion program in order to try to make sense of classroom interaction in Chinese. This finding foregrounds the importance of empirical research in providing informed criteria to modify or confirm established classroom policies and practices.

## Examining Sociocultural and Political Factors

Another important strand of research has focused on sociocultural and political factors involved in immersion teaching and learning, particularly as a result of the internationalization of this type of educational provision. Genesee (2004) has recognized the influence of contextual variables in making predictions about the effectiveness of specific programs, stating:

the question of when to begin bilingual education cannot be answered by theoretical arguments and empirical evidence alone. Socio-cultural and political factors must also be considered. The "best" starting grade for bilingual education can depend on the goals, needs, and resources of the community. (p. 13–14)

This statement by one of the leading researchers in the field constitutes an important milestone in the change of direction toward a more socially informed perspective in immersion research.

In Japan, Downes (2001) has investigated changes toward a sense of Japanese cultural identity among elementary school children in an English immersion program. Mindful of Swain and Johnson's (1997) contention that immersion does not aim at membership in the target language community, the researcher found that the learners' exposure to Western (English) culture provided a positive educational environment and that that participation in the program seemed to lead to more flexible cross-cultural attitudes and a stronger sense of Japanese cultural identity than noted in non-immersion students.

In Australia, de Courcy's (1997) work on classroom language learning in a Chinese late immersion program has led to insights on how cross-cultural conflict is dealt with by students and teachers from different academic cultures and with different, culturally based learning scripts. Points of conflict identified in the study had to do with differing expectations of student interactional patterns in classroom settings, levels of politeness, and teacher responsiveness to learners' needs. De Courcy concludes that "Teachers need to help students to interpret not just the literal meaning of the language, but the cultural meanings expressed through it" (p. 256).

---

## Work in Progress

### Language Acquisition and Development with L1 and L2 Student Populations

In a review of bilingual education, Baker (2003) states "If a count were made of research on bilingual education in the last 3 or 4 years, it is qualitative investigations that have become relatively voluminous" (p. 103). In immersion settings, this is certainly the case if we take into account the recent work on literacy development, classroom code-switching, and learners' perspectives on language learning. However, there is still a strong continuing strand of research based mainly on quantitative criteria focusing on second language acquisition and on program effectiveness from a comparative perspective.

This does not mean, however, that research concerns have not moved on, as can be seen by the work currently being carried out by Merrill Swain, one of the most well known of the immersion researchers, who has been associated with developments in the field since the 1960s. As Block (2003) notes, "Swain . . . is in the unique position of being perhaps the only prominent IIO (Input-Interaction-Output) insider to engage with Sociocultural/Activity Theory in her research" (p. 107). Block also refers to Swain's (2000) move to incorporate a process orientation toward her work on comprehensible output, postulating that this contributes to interactive problem solving and knowledge building, or "collaborative dialogue" among learners, which, in turn, may lead to better levels of target language comprehension.

A study carried out by Hickey (2001) comparing L1 speakers and L2 learners of a target minority language in mixed early immersion programs in Ireland provided evidence that the linguistic composition of the groups significantly affects the frequency of target language use by both L1 speakers of Irish and Irish/English bilinguals, though not L2 learners of Irish. The investigation into the effects of mixing of L1 and L2 learners in the same class showed an important change of orientation from the original Canadian immersion programs, where separation of immersion students from L1 speakers of the target language was part of official immersion policy (Swain 1982). It also bore witness to the increasing diversification of programs and research interests in immersion education.

## Language Learning in Relation to Literacy Development

An interesting development has been research into the phenomenon of literacy *per se*, rather than as part of a general discussion of the relationship between language and content teaching and learning. A study conducted in Canada focused on immersion students' perceptions of their developing biliteracy in Grade 5 and in Grade 7 (Bournot-Trites and Reeder 2005). This was part of their wider longitudinal study to evaluate the effect of increased intensity of exposure to the target language as a means of overcoming the plateau effect in L2 learning. Using interview and questionnaire data, Bournot-Trites and Reeder found a great variety in student perspectives on their process of literacy development and advocated that more attention should be paid to the voices of students in improving learning opportunities.

In more recent developments, Hopewell and Escamilla (2014) have reviewed research on biliteracy in immersion contexts. They found a relative dearth of research on this topic and identified three lines of research as particularly important:

1. The creation of a comprehensive theoretical framework for the development of biliteracy
2. The identification of typical trajectories to biliteracy and how to evaluate them
3. The establishing of pedagogical practices to enhance biliterate competencies

In particular, due to the lack of work carried out on biliteracy and writing, the researchers advocate studies that help “to understand the relationship of biliterate writing to the overall goal of becoming bilingual and biliterate” (p. 190).

## Code-Switching and Classroom Language Use

In line with the focus on sociocultural concerns and the increasing recognition of the situated nature of immersion classroom practices, there is a further strand of research that has begun to concentrate on school and classroom language use, in particular, teacher and pupil use of language choice and code-switching. Thus, the strong separation view of languages that characterized the early work on immersion has now given way to a more integrated, “bilingual” vision of classroom talk. Researchers have turned their attention to the recurrent bilingual routines and communicative practices evident in classroom participants' interaction. As examples of this, I cite two instances of work carried out in South America.

The first study is based on a qualitative study I carried out on storytelling events with young children in immersion classrooms in Colombia (de Mejia 2002). I came to the conclusion that far from being a deficit strategy used to supplement imperfect linguistic proficiency on the part of the teachers, the use of two languages in teaching and learning revealed a sophistication and complexity

of language development often ignored by educationalists. Spezzini (2005) has also been doing work on sociocultural dimensions of language learning and use in English immersion classrooms in Paraguay, within a wider study of language learning variability. She notes that some immersion students are conscious that their code-switched discourse is significantly different from standard usage, and see this as a reflection of their unique identity as students of a particular bilingual school.

Recently, there has been an interesting development in research on English immersion programs in Finland. Cöpp Mökkönen (2013) analyzed classroom interaction in a first and second grade classroom from a critical ethnographic perspective. In her perceptive analysis and interpretation, the researcher focused attention on language choice and code-switching not as isolated acts, but as part of a wider process of negotiation and interpretation of classroom language norms. Thus, the emphasis is on how the participants, both teacher and students, negotiate social positions and classroom community membership and, in so doing, interpret, reinterpret, reproduce, or resist the norms for language use. In this way, Cöpp Mökkönen foregrounded social and cultural concerns rather than pedagogical considerations, showing how in some cases, with the consent of the teacher, some of the students acted at times as language monitors or “policemen” with their peers, showing how “competing ideologies, discourses and powers are contested” (p. 22).

---

## Problems and Difficulties

One of the reasons that this chapter centers on research carried out both in immersion contexts and in CLIL programs is that research into both types of educational provision has tended to be discussed separately, without reference to synergies between both. Although immersion programs have been considered as being the historical precursors of CLIL by the European Commission (Lasagabaster and Sierra 2010), the same authors have noted that most CLIL programs, particularly in Spain, are experimental, whereas immersion programs have been implemented for more than 20 years and can rely on a significant amount of research into both their linguistic and nonlinguistic effects. However, CLIL programs still lack a sufficient number of longitudinal studies to provide researchers with significant empirical data. Thus, although the positive linguistic and nonlinguistic outcomes of immersion programs are extensively documented, this is not the case with CLIL programs. As these authors argue, “further research into the specific characteristics of efficient CLIL programmes is needed” (p. 374). Thus, although it can be seen that CLIL is particularly focused on foreign language teaching and learning, while immersion is traditionally associated with second language development, it is to be hoped that in the future, this separation will be overcome and researchers will be able to focus on aspects of classroom interaction, language choice, and code-switching and sociocultural aspects as evidenced in both traditions.

## Future Directions

Since the change in emphasis on immersion research in the mid-1980s, toward a more process-oriented, classroom-based stance, there have been significant changes in ways in which researchers have chosen to investigate different aspects of immersion students' developing discourses and competences. There has been an increase in longitudinal studies, designed to examine developmental aspects of language learning, academic progress, and sociocultural consciousness of students in immersion programs in many different parts of the world. There has been recognition of the complexity of the processes involved, as well as of the increasing diversity of student and teacher linguistic and cultural backgrounds, and a heightened awareness of the role of code-switching and language choice as a communicative resource and as an indicator of identity.

In a review of immersion programs, Genesee (2004) stated that he considered bilingual classroom discourse as a fruitful avenue for research in the future, asking "Is there a role for bilingual usage – that is, the use of both languages in the same lessons, in bilingual education? In other words, should the languages always be kept separate and if not, how can they be used coextensively to promote language learning?" (p. 574). There, thus, seems to be interest in examining bilingual classroom discourse in immersion settings to see how this is related to the teaching-learning process.

Another area of future research interest has to do with the phenomenon of increasing multilingualism within immersion programs. Although Canadian researchers, such as Genesee, talk about "bilingualism," immersion programs in Finland, Israel, and Australia are having to come to grips with an increasingly multilingual program, designed to prepare students for engagement in a globalized universe. In addition, the introduction of immersion programs involving typologically and orthographically different languages such as Japanese and Chinese has opened up new possibilities for future research, as there is, as yet, little data on students' level of achievement in the written forms of this type of target language (Genesee 2004). In similar vein, Cenoz (2013) makes the case for moving away in future research from "the narrow perspective of CLIL as a foreign language teaching approach . . . to expand it to all the languages being learned and/or used by learners" (p. 393).

Recently, in a special issue dedicated to immersion education in the early years, Hickey and de Mejía (2014) brought together the work of researchers who have studied children between the ages of 2 and 6 years in programs which offer total or partial immersion in various North American and European contexts. The editors discuss the importance of preservice training and mentoring for those who work in early childhood education, as well as the need for the design and implementation of appropriate curricula that allow educators to "integrate appropriate planning for the language learning that is central to every activity and interaction" (p. 139).

There is, thus, evidence to suggest that research on immersion and CLIL programs is moving forward in important ways. Increasing numbers of longitudinal and ethnographic studies are focusing on aspects of classroom interaction, bilingual/

multilingual language use, and sociocultural issues. There is also continuing concern with carrying out comparative research on student achievement in different national contexts throughout the world. In short, it can be seen that since its beginnings in the late 1960s, immersion research has broadened both its methodological outlook and its sphere of interest in line with the spread of immersion programs worldwide. CLIL for its part has spread widely throughout Europe and beyond.

---

## Cross-References

- ▶ [Code-Switching in the Classroom: Research Paradigms and Approaches](#)
- ▶ [Ethnography and Language Education](#)
- ▶ [Interactional Approaches to the Study of Classroom Discourse and Student Learning](#)
- ▶ [Language Teacher Research Methods](#)
- ▶ [Research Approaches to Narrative, Literacy, and Education](#)

---

## Related Articles in the Encyclopedia of Language and Education

Fredricka L. Stoller and Shannon Fitzsimmons-Doolan: [Content-Based Instruction](#).  
In Volume: Second and Foreign Language Education

---

## References

- Arnau, J. (2000). Catalan immersion teachers: Principles of language teaching. *International Journal of Bilingual Education and Bilingualism*, 3(2), 79–100.
- Baker, C. (2003). Education as a site of language contact. *Annual Review of Applied Linguistics*, 23, 95–112.
- Bernhard, T. (Ed.). (1992). *Life in language immersion classrooms*. Clevedon: Multilingual Matters.
- Block, D. (2003). *The social turn in second language acquisition*. Edinburgh: Edinburgh University Press.
- Boumot-Trites, M., & Reeder, K. (2005). *French and English literacy in French immersion: Student performance and perceptions*. 4th International Symposium on Bilingualism. Somerville: Cascadilla Press.
- Cenoz, J. (2013). Discussion: Towards an education perspective in CLIL language policy and pedagogical practice. *International Journal of Bilingual Education and Bilingualism*, 16(3), 389–394.
- Cöpp Mökkönen, A. (2013). An ethnographic study of language socialization and choice in a first and second grade English medium classroom in Finland. *Journal of Immersion and Content-Based Language Education*, 1(2), 279–295.
- Cummins, J., & Swain, M. (1986). *Bilingualism in education*. London: Longmans.
- de Courcy, M. (1997). Teaching and learning with different scripts: Cross-cultural conflict in a Chinese late immersion classroom. *Language and Education*, 11(4), 242–259.
- de Courcy, M. (2002). *Learners' experiences of immersion education: Case studies of French and Chinese*. Clevedon: Multilingual Matters.

- de Mejía, A. M. (2002). *Power, prestige and bilingualism: International perspectives on elite bilingual education*. Clevedon: Multilingual Matters.
- Downes, S. (2001). Sense of Japanese cultural identity within an English partial immersion programme: Should parents worry? *International Journal of Bilingual Education and Bilingualism*, 4(3), 165–180.
- Genesee, F. (2004). What do we know about bilingual education for majority language students? In T. K. Bhatia & W. Richie (Eds.), *Handbook of bilingualism and multiculturalism*. Malden: Blackwell.
- Grandinetti, M., Langellotti, M., & Ting, Y. L. T. (2013). How CLIL can provide a pragmatic means to renovate science education – even in a sub-optimally bilingual context. *International Journal of Bilingual Education and Bilingualism*, 16(3), 354–374.
- Harley, B., & Swain, M. (1984). The interlanguage of immersion students and its implications for second language teaching. In A. Davies, C. Criper, & A. P. R. Howatt (Eds.), *Interlanguage*. Edinburgh: Edinburgh University Press.
- Heller, M. (1990). French immersion in Canada: A model for Switzerland? *Multilingua*, 9(1), 67–85.
- Hickey, T. (2001). Mixing beginners and native speakers in minority language immersion: Who is immersing whom? *The Canadian Modern Language Review*, 57(3), 443–474.
- Hickey, T., & de Mejía, A. M. (2014). Immersion education in the early years: A special issue. *International Journal of Bilingual Education and Bilingualism*, 17(2), 131–143.
- Hopewell, S., & Escamilla, K. (2014). Bilingual development in immersion contexts. *Journal of Immersion and Content-Based Language Education*, 2(2), 181–195.
- Hüttner, J., Dalton-Puffer, C., & Smit, U. (2013). The power of beliefs: Lay theories and their influence on the implementation of CLIL programmes. *International Journal of Bilingual Education and Bilingualism*, 16(3), 267–284.
- Johnson, R. K., & Swain, M. (1997). *Immersion education: International perspectives*. Cambridge: Cambridge University Press.
- Lambert, W. E., & Tucker, G. R. (1972). *Bilingual education of children: The St. Lambert experiment*. Rowley: Newbury House.
- Lapkin, S., & Swain, M. (1984). Research update. In H. H. Stern (Ed.), *The immersion phenomenon* (Language and Society, Special issue, No. 12, pp. 48–54). Ottawa: Commissioner of Official Languages.
- Lasagabaster, D., & Sierra, J. M. (2010). Immersion and CLIL in English: More differences than similarities. *E LT Journal*, 64(4), 367–374.
- Laurén, C. (1992). *Introduction, language acquisition at kindergarten and school. Immersion didactics in Canada, Catalonia and Finland*. Vaasa: University of Vaasa.
- Marsh, D., & Frigols Martín, M. J. (2013). Content and language integrated learning. In C. Chapelle (Ed.), *The encyclopedia of applied linguistics*. London: Blackwell Publishing.
- Navés, T., & Victori, M. (2010). CLIL in Catalonia: An overview of research studies. In D. Lasagabaster & Y. Ruiz de Zarobe (Eds.), *CLIL in Spain: Implementation, results and teacher training*. Bristol: Multilingual Matters.
- Perez-Vidal, C. (2013). Perspectives and lessons from the challenge of CLIL experiences. In C. Abello-Contesse, P. M. Chandler, M. D. López-Jimenez, & R. Chacón-Beltrán (Eds.), *Bilingual and multilingual education in the 21st century. Building on experience*. Bristol: Multilingual Matters.
- Ruiz de Zarobe, Y. (2013). CLIL implementation: From policy-makers to individual initiatives. *International Journal of Bilingual Education and Bilingualism*, 16(3), 231–243.
- Smit, U., & Dafourz, E. (2012). Integrating content and language in higher education: An introduction to English medium policies, conceptual issues and research practices across Europe. *AILA Review*, 25, 1–12.
- Spezzini, S. (2005). English immersion in Paraguay: Individual and sociocultural dimensions of language learning and use. In A. M. de Mejía (Ed.), *Bilingual education in South America*. Clevedon: Multilingual Matters.

- Stern, H. (Ed.). (1984). *The immersion phenomenon* (Language and Society (Special issue, No. 12), pp. 4–7). Ottawa: Commissioner of Official Languages.
- Stern, H. (1990). Analysis and experience as variables in second language pedagogy. In B. Harley, P. Allen, J. Cummins, & M. Swain (Eds.), *The development of second language proficiency*. Cambridge: Cambridge University Press.
- Swain, M. (1982). Immersion education: Applicability for non-vernacular teaching to vernacular speakers. In B. Hartford, A. Valdman & C. Foster (Eds.), *Issues in international bilingual education: The role of the vernacular*. New York: Plenum Press.
- Swain, M. (1983). Bilingualism without tears. In M. Clarke & J. Handscombe (Eds.), *On TESOL '82: Pacific perspectives on language learning and teaching*. Washington, DC: Teachers of English to Speakers of Other Languages.
- Swain, M. (2000). The output hypothesis and beyond: Mediating acquisition through collaborative dialogue. In J. Lantolf (Ed.), *Sociocultural theory and second language learning*. Oxford: Oxford University Press.
- Tardif, C., & Weber, S. (1987). French immersion research: A call for new perspectives. *Canadian Modern Language Review*, 44(1), 67–77.
- Vesterbacka, S. (1991). Ritualised routines and L2 acquisition: Acquisition strategies in an immersion program. *Journal of Multilingual and Multicultural Development*, 12(1 & 2), 35–43.



---

# Linguistic Ethnography

Angela Creese and Fiona Copland

---

## Abstract

This chapter introduces the developing field of linguistic ethnography. The work of scholars who are particularly influential in linguistic ethnography is discussed – in particular, Hymes, Gumperz, Goffman, and Erickson – and linked to the work of scholars currently working in this field, including Creese, Roberts, Rampton, and Lefstein and Snell. Drawing on contextual realities and mainly North American historical antecedents, it explains why linguistic ethnography is mainly a European endeavor and why it has emerged at this point in time. In particular, the chapter suggests that the formation of the linguistic ethnography forum (LEF: [www.lingethnog.net](http://www.lingethnog.net)) is centrally important in providing a community of practice for researchers using ethnography and linguistic analysis in their work. The chapter also points to the increasing impact of interdisciplinarity on the development of linguistic ethnography. It argues that its democratic approach to participation and interpretation of local perspectives is often a good starting point around which interdisciplinary teams can cohere. In conclusion, the chapter suggests that the ability to work collaboratively with professional groups and like-minded researchers has been one of the main benefits of the development of the field and that it is this breadth and reach which hold the most promise for linguistic ethnography.

---

## Keywords

Anthropology • Discourse • Interdisciplinarity • Metatheorists • Postmodernity

---

A. Creese (✉)

MOSAIC Center for Research on Multilingualism, University of Birmingham, Birmingham, UK  
e-mail: [a.creese@bham.ac.uk](mailto:a.creese@bham.ac.uk)

F. Copland (✉)

Faculty of Social Sciences, University of Stirling, Stirling, United Kingdom  
e-mail: [fiona.copland@stir.ac.uk](mailto:fiona.copland@stir.ac.uk)

## Contents

Introduction .....	340
Early Developments .....	340
Major Contributions and Work in Progress .....	341
Dell Hymes (1927–2009) .....	341
John Gumperz (1922–2013) .....	343
Erving Goffman (1922–1982) .....	343
Frederick Erickson .....	344
Problems and Difficulties .....	345
A Moment in Time .....	346
The Interdisciplinary Agenda .....	346
Postmodernity .....	347
Future Directions .....	348
Cross-References .....	349
Related Articles in the Encyclopedia of Language and Education .....	349
References .....	349

---

## Introduction

Linguistic ethnography is an interpretive approach which studies the local and immediate actions of actors from their point of view and considers how these interactions are embedded in wider social contexts and structures. It is a “disciplined way of looking, asking, recording, reflecting, comparing, and reporting” (Hymes 1980, p. 105), combining an enhanced sense of the strategic value of discourse analysis (Rampton et al. 2004) with ethnography. Linguistic ethnography, a mainly European phenomenon, has been greatly influenced by North American scholarship in linguistic anthropology, and because of this we share many of the same antecedents. Indeed, a common bedrock of “metatheorists” (McElhinny et al. 2003, p. 316) such as Gumperz and Hymes, Goffman and Erickson, Agha and Silverstein, Gal and Heller, and Blommaert and Rampton highlights the theoretical and methodological backgrounds we share. The emergence and development of linguistic ethnography in Europe and rationale for its gathering momentum can be found in its ability to cluster and network groups of researchers who might otherwise be fairly isolated (for overviews, see Creese and Copland 2015; Creese 2008; Maybin and Tusting 2011; Rampton 2007b; Rampton et al. 2004; Rampton et al. 2015; Tusting and Maybin 2007).

---

## Early Developments

In 1921, Sapir suggested “language does not exist apart from culture, that is, from the socially inherited assemblage of practices and beliefs that determines the textures of our lives” (p. 207). According to Sapir, language and culture are inseparable. Culture is not a fixed set of practices essential to ethnic or otherwise-defined groups. Language is not an unchanging social structure unresponsive to the communicative

needs of people. Rather languages and cultures are practices and processes in flux, up for negotiation, but contingent on specific histories and social environments. This view of language and culture as processes rather than products finds long-term support in anthropology and ethnography. Goodenough (1994) summarizes this view:

I have found it theoretically helpful to think of both culture and language as rooted in human activities (rather than in societies) and as pertaining to groups. The cultural make-up of a society is thus to be seen not as a monolithic entity determining the behaviour of its members, but as a melange of understanding and expectations regarding a variety of activities that serve as guides to their conduct and interpretation. (p. 266–7)

The interpretation of meaning is at the heart of Goodenough's definition. We come to "understand and expect" through the mundane routines we engage in regularly. The imperative to uncover the mundane, routine, and everyday was described by leading linguistic anthropologist Dell Hymes in the 1960s when he spoke about bringing anthropological research "back home" (in Rampton 2007a, p. 598). Hymes was keen to argue that we needed to study "ourselves" rather than the "other" using the skills and knowledge of the ethnographer. In particular, Hymes brought his authority as a leading scholar in linguistic anthropology to the social sciences where he set about investigating linguistic inequality as both a practical and theoretical problem. The necessity of looking in "our own backyard to understand shifting cultural meanings, practices and variations" (Rampton 2007a, p. 598) has been well made in ethnography.

---

## Major Contributions and Work in Progress

In this section, we draw on Creese and Copland (2015) to foreground four scholars who share an interest in language, culture, society, and interaction and whose work has had an impact on key scholars working in linguistic ethnography in the European context. We summarize the work of these scholars and link it to current work in progress.

### Dell Hymes (1927–2009)

A theory of language and social life is Dell Hymes' major contribution to the field. He saw multiple relations between language and society and between linguistic means and social meaning. Back in the 1960s and the heyday of Chomskyan grammatical competence, Hymes criticized linguistics for making its focus the structure of language (langue), rather than the cultural actions of communities in context (parole). In 1974 he wrote "Linguistics, the discipline central to the study of speech, has been occupied almost wholly with developing analysis of the structure of language as a referential code" (p. 32). He felt that such a focus on the part of linguistics was deliberate and the failure to provide an explicit place for

sociocultural features was not accidental (Hymes 1972, p. 272). He accused linguistics of taking a “Garden of Eden” view of language which consisted of an ideal speaker who was grammatically competent – existing as an “unmotivated cognitive mechanism, . . . not a person in the social world” (Hymes 1972, p. 273). Hymes called for an analysis of speech (*parole*) over language (*langue*) to articulate how social action and speech interact in “a systematic, ruled and principled way” (Hymes 1968, p. 101). He developed and advocated the “ethnography of communication” because linguistics was not utilizing the “multiple relations between linguistic means and social meaning” (1974, p. 31). Furthermore, he argued that humankind “cannot be understood apart from the evolution and maintenance of its ethnographic diversity” (Hymes 1974, p. 33). He therefore proposed studying “speaking” and “communication” over “language.” For Hymes, and others committed to a sociolinguistic perspective, the analysis of speech over language shifted the direction away from code to actual use. This point is taken up by Blommaert et al. (2010), who similarly argue, “speech is language in which people have made investments – social, cultural, political, individual-emotional ones” (p. 8). Blommaert and Jie make a distinction between a linguistic notion of language and an ethnographic notion of discourse. This battle for a more social orientation to the study of language rumbles on to this day with linguistic anthropologists arguing that a continued focus on *langue* or code is restrictive, extractionist, and exclusionary (Agha 2005).

Hymes’ influence has been a major influence in the field of language education. His riposte to Chomsky contributed significantly to a pedagogy based not solely on grammar but on social appropriateness. His concept of “communicative competence” (1972) redirected language education and its professionals to think about setting, people, register, function, and style. He was greatly influenced by the work of Edward Sapir (1921) and Roman Jakobson (1960) whose work focused on the components and functions of the speech situation. Hymes was committed to understanding how speech resources come to have uneven social value and saw the possibilities of applying a linguistic or discourse analysis across disciplines to “build answers to new questions thrown up by social change” (Hymes 1974, p. 32). His orientation was interdisciplinary in nature.

Angela Creese (2005) used Hymes’ framework to show how different teacher roles attracted varying degrees of institutional support and the implication of this for emergent bilingual young people. Hymes’ concept of the speech situation, event, and act was used by Creese to record diversity of speech, repertoires, and ways of speaking in three linguistically diverse London secondary schools. Subject teachers and teachers of English as additional language foregrounded different language functions in their interaction with emergent bilingual students resulting in different relationships, identity constructions, and learning opportunities for young people. Creese linked her micro recordings of classroom interactions to macrostructures of educational power. Today, Creese continues to work within a Hymesian framework drawing on the speech act to consider the knowledge speakers share about utterances as they translanguage in their everyday multilingual discourses (Creese and Blackledge 2015; Blackledge and Creese 2010).

## John Gumperz (1922–2013)

A major contribution by John Gumperz was his development of a line of work usually referred to as “interactional sociolinguistics” which focuses on everyday talk in social contexts (Gumperz 1982). It considers how societal and interactive forces merge in the small and mundane conversations that people regularly have. The goal of interactional sociolinguistics is to analyze how people interpret and create meanings in interaction. An important concept is the “contextualization cue,” which Gumperz (1999) describes as the functioning of signs “to construct the contextual ground for situated interpretation” (p. 461). Gumperz was interested in understanding how people read clues to construct meaning.

An interactional sociolinguistic (IS) approach focuses on meaning in action. It highlights the uniqueness of the moment and context while simultaneously acknowledging the social structures brought into play. That is, although the focus is on the here and now of the encounter at hand, the “there and then” of the world beyond is ever present. As Gumperz (1999) argues, even the most straightforward interaction depends on shared, tacit knowledge, both cultural and linguistic.

In the UK, Celia Roberts has pioneered an IS approach, combining the focus on interaction with social theory. For example, her 2001 work with Srikant Sarangi, “‘Like you’re living two lives in one go’: Negotiating different social conditions for classroom learning in a further education context in England,” shows how educational contexts create expectations about classroom interaction which can be upheld or subverted by participants, leading to different educational outcomes. Acknowledging the classroom as a particular cultural space, and the participants as actors belonging to social and cultural groups, means that IS can be used to examine interactions between participants living in the same country and speaking the same language. Indeed, Roberts has consistently and effectively used IS to draw attention to inequality suffered by minority ethnic groups and to show how these inequalities are realised through talk. Recently, Roberts has brought a Gumperzian perspective to job interviews (2011) and health consultations (2011, 2014, with Deborah Swinglehurst and others). She has also coedited a special issue of *Text and Talk* on the work of Gumperz with Peter Auer (2011).

## Erving Goffman (1922–1982)

Erving Goffman (e.g. 1967, 1981), a Canadian-born sociologist and cultural theorist, carried out fieldwork in a number of countries and developed a range of theoretical perspectives for examining how people behave in different social settings. The resurgence in interest in his work is testament to the longevity of his ideas and their relevance for developing understanding of talk in context. Goffman observed that the social situation is the basic unit or scene in which everyday life takes place (Erickson 2004a). Through painstaking attention to the details of interaction in social situations, he noted the rituals, routines, and performances of daily life. From this study, Goffman developed a huge number of theoretical constructs that can be used

to interpret and explain everyday talk. Many of these draw on dramaturgical metaphors and draw attention to the performative aspects of identity and talk.

One of many important theoretical contributions made by Goffman is his work on face. He described face as “the positive social value a person effectively claims for himself by the line others assume he has taken during a particular contact” (Goffman 1967, p. 5). His conceptualization launched a whole new area of pragmatic research, with Brown and Levinson (1987) arguing that interlocutors are aware of each other’s face needs, leading to engagement in complex linguistic gymnastics as they aim to protect, or not, these needs.

Ben Rampton has drawn extensively on Goffman in his work and has also been instrumental in championing Goffman in his teaching of ethnography, language, and communication. In *Language in Late Modernity: Interaction in an Urban School* (2006), Rampton shows how teenagers in an urban school use German, a language taught in school but to which students seem to have little or no out-of-school affiliation, to perform a range of functions (such as apologizing and commanding). He draws on Goffman’s concept of “interpersonal verbal rituals” (Goffman 1981, p. 21) to suggest that students use German to do facework particularly when their independence, territory, or good character is threatened (Rampton 2006, p. 166). Using German in a ritualistic way allows the students to attend to both their own face needs and to those of their interlocutors. More recently, Rampton (2014) uses a number of Goffmanian constructs (e.g., “imprecations,” “threat startles,” and “grandstanding”) to interrogate language and ethnicity among adolescents in London.

## Frederick Erickson

Frederick Erickson (1990, 2004b) describes his approach as a “practical activity” using video recordings of “naturally occurring interactions” to look “closely and repeatedly at what people do in real time as they interact” (Erickson 1996, p. 283). Erickson’s approach is known as microethnography as he examines “big social issues through careful examination of ‘small’ communicative behaviours on the microlevel” (LeBarron 2008, p. 177).

In the examination of “small communicative behaviors,” microethnography is concerned with the local ecology of speaker and listener relations and the micropolitics of social relations between people rather than with the individual. The immediate ecology of relations between participants focuses on how people in interaction “constitute environments for each other’s activities” (McDermott 1976, p. 36). This requires paying attention to the nonverbal, particularly gaze, gesture, and posture, as well as the verbal. Speaking and listening have a mutual influence on one another and can be said to have a rhythmic organization (Erickson 1996, p. 288).

Regarding “big social issues,” Erickson uses microethnography in two ways. First, he identifies the relationships between interaction and processes of society.

Second, he shows how interactions are situated in historical and societal contexts (Erickson 2004a). For example, in *Seventy-five dollars goes in a day* (2004b), Erickson's meticulous analysis of dinner table talk demonstrates that the discussion focuses repeatedly on the spiraling cost of living for a lower-middle-class family in the USA in 1974. In terms of societal processes, the discussion is the opportunity for "language and discourse socialisation" (p. 50) to take place as the family learns to talk not just about the economy in general but about the particular circumstances of their dwindling financial resources. The topic of cost and limited income has clear relevance for this family given their material circumstances, and Erickson argues that the discussion is class-based as those on higher incomes would not be discussing the issue with the same level of anxiety. In terms of situating interactions in "historical and societal contexts," Erickson links the resentment talk at the dinner table to a growing dissatisfaction in similar families about rising costs, which leads in time to the formation of a discourse. He suggests that this kind of talk "acted in synergy with large-scale social processes" to "sweep Reagan into the White House" (p. 51), drawing on evidence that families such as this switched allegiance and voted in their millions for a Republican.

Erickson's belief in the value of video recording to capture nonverbal processes and their relationship with verbal processes has helped to inspire linguistic ethnographers to develop multimodal approaches to their research (e.g., the work of Lefstein and Snell 2013). Furthermore, microethnographic working, focusing on the detail of unfolding talk and action, has had an enormous influence on analytical processes of those working within linguistic ethnography, both with video (e.g., Bezemer 2015; Swinglehurst 2015) and without (e.g., Rampton 2006, 2014; Rock 2015).

A number of researchers working with linguistic ethnography have acknowledged Erickson's influence in terms of both theory and method. Theoretically, Copland (2011), Rampton (2009), and Rampton et al. (2015) in discussions of genres of talk all draw on the concept of "wobble room," that is, "just a little bit of space for innovation within what's otherwise experienced as the compelling weight of social expectation" (Rampton et al. 2015). Methodologically, the increasing focus on the body in linguistic ethnographic studies, for example, Bezemer (2008) and Lefstein and Snell (2013), has been greatly influenced by Erickson's work.

---

## Problems and Difficulties

It will have been noted that the influential scholars listed here are North Americans. Given this, readers may well find themselves asking, why do we need linguistic ethnography? What's wrong with linguistic anthropology? As we have shown, we are keen to emphasize continuities with linguistic anthropology rather than make claims of distinction. Nevertheless, the appearance of linguistic ethnography in Europe has not happened by accident. In this section we seek to explain its emergence.

## A Moment in Time

According to Rampton (2007a, p. 594), there is no “properly institutionalized” linguistic anthropology in Britain. British scholars pursuing an interest in language, culture, and society, therefore, have had no established local intellectual community in which to situate themselves. As a result, these scholars turned to the annual meetings of the British Association of Applied Linguistics (BAAL) to fine-tune their analytical conversations. BAAL meetings created a context for contact and cross-fertilization resulting in the coming together of scholars with a distinctive mix of traditions. Maybin and Tusting (2011) describe how linguistic ethnographers have been drawn to the disciplinary frameworks of linguistics and sociolinguistics through BAAL’s remit.

A key moment for linguistic ethnography came in 2001 when the linguistic ethnography forum (LEF: <http://www.lingethnog.org/>) was established as a special interest group of BAAL. LEF scholars were “pushed together by circumstance, open to the recognition of new affinities, and sufficiently familiar with one another to treat differences with equanimity” (Rampton 2007a, p. 585). Since 2008, LEF has held a biennial conference where these affinities and differences have been debated and where emerging work in linguistic ethnography has been presented. Both LEF and the conference have also attracted many like-minded European scholars who have also lacked an intellectual home. A special issue of the journal *Text and Talk* (2010) describes European perspectives on linguistic ethnography (see Flynn et al. 2010; Jacobs and Slembrouck 2010).

Linguistic ethnography has clustered a community of scholars around its themes and heritages and brought together doctoral students, early- and mid-career researchers, and senior academics. Within these clusters of scholarship, different conversations between academics have seen some traditions of discourse analysis become established, and robust and new kinds of conversation around language and ethnography develop. Emerging researchers are now citing the work of established British and European linguistic ethnographic scholars as well as their American influences. Although too early to speak of its legacy, linguistic ethnography has created a forum to develop researcher capacity at a key moment in time.

## The Interdisciplinary Agenda

Within UK higher education, and in other countries as well, there has been a general shift away from the organization of academic knowledge in terms of disciplines to one that is based on interdisciplinarity (Creese 2010; Rampton 2007a). Many universities in the UK are undergoing a reorganization in search of “effective structures and mechanisms to encourage and foster inter-disciplinary activity” (University of Birmingham website, 2009). This is mirrored in the research funding bodies in the UK and Europe. In the UK, there is a new emphasis on interdisciplinary research, and funding is made available to achieve “beneficial societal impact.” Teams of academics from the social sciences, environmental sciences, and the



humanities might find themselves working together on a project and debating methodologies which can best respond to the questions being asked.

Rampton et al. (2015) describe two modalities of doing interdisciplinary research. The first approach brings different academic disciplines together to work on a problem. Cross-referencing to different paradigms can be made to investigate the phenomena at hand, and researchers commonly move out of their comfort zone in discussion with colleagues as they learn about different ways to research the phenomenon. In the second approach to interdisciplinarity, “‘real-world’ issues of social, technical and/or policy relevance provide the starting point” (Rampton et al. 2015), and collaborations between academic and nonacademic institutions in the private, public, and third sectors are common. Such partnerships foster joint planning, question setting, and a commitment to bring different expertises, experiences, and knowledge to address the challenge.

Ethnography with its democratic approach to participation and interpretation of local perspectives is often a good starting point around which interdisciplinary teams can cohere. Moreover, because language is at the heart of any exercise in social life, linguistic ethnographers have a key role to play. Agha (2005) speaks of the “linguistic turn” in the humanities and social sciences, which he defines as “a vast number of intellectual projects that take up particular aspects of human affairs mediated by language, in a variety of modes of departmental, disciplinary, and inter-disciplinary organizations” (p. 228). Furthermore, he describes the dangers of staying too narrowly focused within the disciplinary boundaries of linguistics:

Linguists of a certain type might well say, ‘That’s not linguistics.’ But no one cares. For the reciprocal fact is this: the ‘linguistic turn’ is an orientation to the linguistic aspect of human affairs not toward what happens in departments of linguistics. (p. 228)

Discourse analysis presents a set of methodological tools that are attractive to many in the social sciences. Linguistic ethnography in particular is open to a wide variety of discourse analytic traditions in its combination with ethnography. Through its focus on discourse and detailed interactional analysis, linguistic ethnography is already adopted in a variety of disciplines (Snell et al. 2015). However, there are productive tensions in engaging in interdisciplinary scholarship. What constitutes data may radically differ across disciplines, and the ontological and epistemological underpinnings of each discipline may fundamentally conflict. Furthermore, disciplines differ in what they constitute as their object of study or unit of analysis and this shapes the organization of research activity.

## Postmodernity

Modernist ideas of language seek order and purity and reject “hybridity” (Blommaert et al. 2012). In structuralist linguistics, various techniques were and still are employed to identify and classify features of sentence structures and to categorize these into constituent parts. Modernist ideologies of language “centered

on denotational functions” and sought to count, bound, and structure strings of signs, particularly at the sentence level (Blommaert 2010, p. 10). Such a view of language is often put to work for “higher-scale institutional hegemonies” like national language policies and educational policies, resulting in the “national language” constructed as one of the purest icons of the nation state. As Blommaert et al. (2012) point out, if you are viewed as speaking a pure language, you are authenticated as a real member of a particular culture, a common modernist view.

Postmodernist approaches to the study of language deconstruct these “entitlements” or social constructions. Deconstruction involves processes of scrutiny which pull apart dichotomies such as “order versus disorder; purity versus impurity; normality versus abnormality” (Blommaert et al. 2012, p. 5). Linguistic ethnography is well placed to investigate the construction and robustness of social categories and categorization processes and taken for granted assumptions about groups, categories, and peoples. Indeed to date, linguistic ethnographers have played their part in the rapid debunking of reifications and essentializations about languages, dialects, ethnicities, and cultures in the economic and social processes of globalization (e.g., Blackledge and Creese 2010, 2014; Lefstein and Snell 2013).

Postmodernism makes clear that assumptions are dangerous. In linguistic ethnography, assumptions about communicative practices in particular are challenged and must be empirically investigated as the earlier review of Erickson illustrated. However, as Maybin and Tusting (2011) point out, this is a “formidable” task. Heller (2011) explains why:

The challenge is to capture the ways in which things unfold in real time, and the ways in which they sediment into constraints that go far beyond the time and place of specific interactions. (p. 400)

Linguistic ethnographers see attention to the “sign” in discourse as a means to linking to wider historical, social, political, and cultural structures as one way forward to responding to this challenge (Creese and Copland 2015).

---

## Future Directions

Linguistic ethnography views language as communicative action functioning in social contexts in ongoing routines of peoples’ daily lives. It looks at how language is used by people and what this can tell us about wider social constraints, structures, and ideologies. It achieves this by investigating the linguistic sign as a social phenomenon open to interpretation and translation but also predicated on convention, presupposition, and previous patterns of social use.

With no local scholarship to turn to researchers doing work combining linguistics and ethnography in Europe had no natural home. Linguistic ethnography has provided one. In the European context, an interdisciplinary orientation is gaining momentum, and scholars who can combine approaches to data collection and analysis to work collaboratively with differently minded researchers are likely to

be in demand. Linguistic ethnographers have a tradition of working with professional groups (see Lefstein and Snell 2013; Roberts 2012) and have already made a significant contribution to the interdisciplinary agenda. Research “with” rather than “on” follows in the interdisciplinary orientation first advocated by Hymes. In addition, linguistic ethnographers’ contribution to postmodernity and its deconstruction of social categories have been particularly relevant in terms of new and emergent constructions of language, culture, ethnicity race, and diversity (Blommaert and Rampton 2014; Creese and Blackledge 2012). Indeed, Blommaert and Rampton (2012) recently argue in a paper on superdiversity that the combination of linguistics and ethnography “produces an exceptionally powerful and differentiated view of both activity and ideology” (p. 3) and so is well placed to support research into this complex and exciting area.

More than this, linguistic ethnography continues to provide an important home for a wide range of disciplines including those working in literacy studies, health policy and communication, workplace interaction, classrooms and educational settings, language and superdiversity, online and digital worlds, and narratives and identity. Perhaps, it is breadth and reach that hold the most promise for linguistic ethnography.

---

## Cross-References

- ▶ [Discourse Analysis in Educational Research](#)
- ▶ [Ethnography and Language Education](#)
- ▶ [Ethnography of Language Policy](#)
- ▶ [Microethnography in the Classroom](#)

---

## Related Articles in the Encyclopedia of Language and Education

Betsy Rymes: [Language Socialization and the Linguistic Anthropology of Education](#). In Volume: Language Socialization

Stanton Wortham and Sabina Perrino: [Linguistic Anthropology of Education](#). In Volume: Discourse and Education)

---

## References

- Agha, A. (2005). Voice, footing, enregisterment. *Journal of Linguistic Anthropology*, 15(1), 38–59.
- Bezemer, J. (2008). Displaying orientation in the classroom: Students’ multimodal responses to teacher instructions. *Linguistics and Education*, 19(2), 166–178.
- Bezemer, J. (2015). Partnerships in research: Doing linguistic ethnography with and for practitioners. In Snell, J., Shaw, S., & Copland, F. (Eds.), *Linguistic ethnography: Interdisciplinary explorations*. London: Palgrave Macmillan
- Blackledge, A., & Creese, A. (2010). *Multilingualism: A Critical Perspective*. London: Continuum.

- Blommaert, J. (2010). Policy, policing and the ecology of social norms: Ethnographic monitoring revisited. *Working Papers in Urban Language & Literacies*. Paper 63.
- Blommaert, J., Dong, J., & Jie, D. (2010). *Ethnographic fieldwork: A beginner's guide*. Bristol: Multilingual Matters.
- Blommaert, J., Leppänen, & Spotti, M. (2012). Endangering multilingualism. In J. Blommaert, S. Leppänen, P. Pahat, & T. Räisänen (Eds.), *Dangerous multilingualism: Northern perspectives on order, purity and normality*. Basingstoke: Palgrave MacMillan.
- Brown, P., & Levinson, S. (1987). *Politeness: Some universals in language use*. Cambridge: Cambridge University Press.
- Copland, F. (2011). Negotiating face in the feedback conference: A linguistic ethnographic approach. *Journal of Pragmatics*, 43(15), 3832–3843.
- Creese, A. (2005). *Teacher collaboration and talk in multilingual classrooms*. Clevedon: Multilingual Matters.
- Creese, A. (2008). Linguistic ethnography. In K. A. King & N. H. Hornberger (Eds.), *Encyclopedia of language and education: Research methods in language and education* (2nd ed., Vol. 10, pp. 229–241). New York: Springer.
- Creese, A. (2010). Linguistic ethnography. In E. Litosseliti (Ed.), *Research methods in linguistics* (pp. 138–154). London: Continuum.
- Creese, A., & Blackledge, A. (2015). Translanguaging and identity in educational settings. *Annual Review of Applied Linguistics*, 35, 20–35.
- Creese, A., & Copland, F. (2015). *Linguistic ethnography: Collecting, analysing and presenting data*. London: Sage.
- Erickson, F. (1990). Qualitative methods. In R. L. Linn & F. Erickson (Eds.), *Research in teaching and learning* (Vol. 2). New York: MacMillan Publishing Company.
- Erickson, F. (1996). Ethnographic microanalysis. In S. L. McKay & N. H. Hornberger (Eds.), *Sociolinguistics and language teaching* (pp. 283–306). New York: Cambridge University Press.
- Erickson, F. (2004a). Demystifying data construction and analysis. *Anthropology and Education Quarterly*, 35(4), 486–493.
- Erickson, F. (2004b). *Talk and social theory*. Cambridge: Polity Press.
- Flynn, P., van Praet, E., & Jacobs, G. (2010). Emerging linguistic ethnographic perspectives on institutional discourses. *Text & Talk*, 30(2), 97–103.
- Goffman, E. (1967). *Interaction ritual*. New York: Pantheon.
- Goffman, E. (1981). *Forms of talk*. Oxford: Blackwell.
- Goodenough, W. H. (1994). Toward a working theory of culture. In R. Borosky (Ed.), *Assessing cultural anthropology* (pp. 262–273). New York: McGraw Hill.
- Gumperz, J. J. (1982). *Discourse strategies*. Cambridge: Cambridge University Press.
- Gumperz, J. J. (1999). On interactional sociolinguistic method. In S. Sarangi & C. Roberts (Eds.), *Talk, work and institutional order* (pp. 453–471). Berlin: Mouton de Gruyter.
- Heller, M. (2011). *Paths to post-nationalism. A critical ethnography of language and identity*. New York: Oxford University Press.
- Hymes, D. (1968). The ethnography of speaking. In J. Fishman (Ed.), *Readings in the sociology of language* (pp. 99–138). The Hague: Moulton.
- Hymes, D. (1972). On communicative competence. In J. B. Pride & J. Holmes (Eds.), *Sociolinguistics* (pp. 269–293). Harmondsworth: Penguin.
- Hymes, D. (1974). *Foundations in sociolinguistics: An ethnographic approach*. Philadelphia: University of Philadelphia Press.
- Hymes, D. (1980). *Language in education: Ethnolinguistic essays. Language and ethnography series*. Washington, DC: Center for Applied Linguistics.
- Jacobs, G., & Slembrouck, S. (2010). Notes on linguistic ethnography as a liminal activity. *Text & Talk*, 30(2), 235–244.
- Jakobson, R. (1960). *Linguistics and poetics. From selected writings II*. The Hague: Mouton.
- LeBarron, C. (2008). Microethnography. In W. Donsbach (Ed.), *The International Encyclopedia of Communication* (pp. 763–72). Oxford: Blackwell.

- Lefstein, A., & Snell, J. (2013). *Better than best practice: Developing learning and teaching through dialogue*. London: Routledge.
- Maybin, J., & Tusting, K. (2011). Linguistic ethnography. In J. Simpson (Ed.), *Routledge handbook of applied linguistics* (pp. 515–528). Abingdon: Routledge.
- McElhinny, B., Hols, M., Holtzner, J., Neunger, S., & Hicks, C. (2003). Gender, publication and citation in sociolinguistics and linguistic anthropology. *Language in Society*, 32, 299–328.
- McDermott, R. P. (1976). 'Kids make sense: An ethnographic account of the interactional management of success and failure in one first grade classroom'. Stanford University, CA: Unpublished PhD dissertation.
- Rampton, B. (2006). *Language in late modernity: Interaction in an urban school*. Cambridge: Cambridge University Press.
- Rampton, B. (2007a). Neo-Hymesian linguistic ethnography in the United Kingdom. *Journal of Sociolinguistics*, 11(5), 584–607.
- Rampton, B., (2007b). Linguistic ethnography, interactional sociolinguistics and the study of identities. *Working Papers in Urban Language and Literacies*, 43.
- Rampton, B. (2009). Interaction ritual and not just artful performance in crossing and stylization. *Language in Society*, 38(02), 149–176.
- Rampton, B. (2014). *Crossing: Language and ethnicity among adolescents* (2nd ed.). London: Routledge.
- Rampton, B., Tusting, K., Maybin, J., Barwell, R., Creese, A., Lytra, V. (2004). *UK linguistic ethnography: A discussion paper*. Unpublished. [www.lingethnog.org.uk](http://www.lingethnog.org.uk)
- Rampton, B., Maybin, J., Roberts, C. (2015). Introduction: Explorations and encounters in linguistic ethnography. In J. Snell, S. Shaw, F. Copland (Eds.), *Linguistic ethnography: Interdisciplinary explorations*. London: Palgrave Macmillan.
- Roberts, C. (2011). Gatekeeping discourse in employment interviews. In C. Candlin & S. Sarangi (Eds.), *Handbook of communication in organisations and professions* (pp. 407–432). Berlin: Mouton de Gruyter.
- Roberts, C. (2012). Translating global experience into global models of competency: Linguistic inequalities in the job interview. *Diversities*, 14(2), 49–72.
- Rock, F. (2015). Bursting the bonds: Policing linguistic ethnography. In J. Snell, S. Shaw, F. Copland (Eds.), *Linguistic ethnography: Interdisciplinary explorations*. London: Palgrave Macmillan.
- Sapir, E. (1921). *Language: An Introduction to the study of speech*. London: Hart-Davies.
- Snell, J., Shaw, S., & Copland, F. (Eds.) (2015). *Linguistic ethnography: interdisciplinary explorations*. Palgrave Macmillan.
- Swinglehurst, D. (2015). How linguistic ethnography may enhance our understanding of electronic patient records in healthcare settings. In J. Snell, S. Shaw, F. Copland (Eds.), *Linguistic ethnography: Interdisciplinary explorations*. London: Palgrave Macmillan.
- Tusting, K., & Maybin, J. (2007). Linguistic ethnography and interdisciplinarity: Opening the discussion. *Journal of Sociolinguistics*, 11(5), 575–583.

---

# Arts-Based Approaches to Inquiry in Language Education

Melisa Cahnmann Taylor

---

## Abstract

What does it mean to engage in arts-based research? Where does this tradition come from and how has it been accepted in the world of language education research and scholarship? This chapter defines arts-based research, identifying early developments, major contributions, and the current state of the field. Numerous contributors' works, or scholARTistry, are discussed and new questions are raised regarding arts-based research quality, utility, ethical validity, and feasibility. Arts-based approaches to inquiry are not presented as an "either-or" proposition to traditional research paradigms. Rather, the literary, visual, and performing arts are discussed as a means to stretch the researcher's capacity for creativity and knowing, creating a healthy synthesis of approaches to collect, analyze, and represent data in ways that paint a full picture of a heterogeneous movement to improve language education.

---

## Keywords

Arts-based research • Poetic inquiry • Ethnodrama • Ethnopoetry • Anthropological poetics • ScholARTistry

## Contents

Introduction .....	354
Early Developments .....	354
Major Contributions: "Blurred Genres" .....	355
Works in Progress: "Arts-Based Inquiry" Is Born .....	356
Hybrid Forms .....	357
Art for Scholarship's Sake .....	358

---

M.C. Taylor (✉)

Language and Literacy Education, University of Georgia, Athens, GA, USA

e-mail: [cahnmann@uga.edu](mailto:cahnmann@uga.edu)

---

Problems and Difficulties .....	360
Future Directions and Possibilities .....	362
Cross-References .....	364
References .....	364

---

## Introduction

With the acceptance of postmodern approaches to language research in the last few decades including feminism, poststructuralism, critical theory, and semiotics, assumptions about what counts as knowledge and the nature of research have dramatically changed. The tools we use to collect data and display findings have diversified to include artistic as well as scientific methods. Arts-based approaches to inquiry refer to the use of the literary, visual, and performing arts through all stages of research. For example, there has been recent interest and support for including poetry, story, theater, and visual image as methods during data collection and analysis to increase researchers' attention to complexity, feeling, and new ways of seeing. Researchers increasingly turn to artistic forms of representation to communicate findings in multidimensional, penetrating, and more accessible ways to larger and more diverse audiences.

---

## Early Developments

Artistry has often been as much a part of what language researchers have drawn upon in their research process as science. This ranges from the visual clarity and originality of graphic organizers to represent findings to hybrid writing styles that include rich, evocative language to describe the research field and share quoted speech from interviews. However, early developments of language education research methodology were rarely explicit about the place of art in scholarship.

Since the beginning of the study of language in anthropology, linguistics, and education, researchers have been particularly close to what Dewey (1934) described as the *aesthetic experience* involved in teaching, learning, researching, and communicating within and across different speech communities. For example, the Sapir-Whorf (1956) theory of linguistic relativity, although largely discredited, had tremendous influence on early studies of language and culture, influencing the emergence of *ethnopoetics* as a field of study. Ethnopoetics, a field coined by poet-ethnographer Jerome Rothenberg in 1968 (Brady 2000), focused largely on differences in aesthetics between indigenous verbal artists and Western literary traditions. Ethnopoetics was of central concern to linguistic anthropologist, Dell Hymes, in his research among Native American communities. Hymes (1964), the first to propose the "ethnography of communication" as a merged field between linguistics and anthropology, was himself a poet, who for years had been judging an annual poetry contest for the Society for Humanistic Anthropology.

Despite the implicit connections between early language education research and the arts, there were few, if any, explicit references to the arts in research before 1980. As to artistic products, there were fewer still. In fact, one of the first female anthropologists, Ruth Benedict (1934), whose book, *Patterns of Culture*, was one of the first to introduce the public at large to cultural diversity, published her poetry under pseudonyms to keep them hidden from her mentor, Franz Boas, and other academic colleagues (Behar 2008, pp. 59–60). By mentioning the arts in academic study, one risked leaving the impression that one’s research was less a piece of scholarship than a fictive invention. For some researchers, these fears gave way to a postmodernist turn in research, one that became disenchanted with absolute knowledge and objectivity in favor of “an epistemology of ambiguity . . . [celebrating] meanings that are partial, tentative, incomplete, and sometimes even contradictory and originating from multiple vantage points” (Barone 2001, pp. 152–153). It was not until the 1980s that language education researchers and others in the social sciences began to embrace this postmodern turn. What later came to be called “arts-based research” (ABR) was born in 1993 when Elliot Eisner secured American Education Research Association (AERA) support for a two and a half day institute held at Stanford (Barone and Eisner 2012). Arts-based inquiry, schol-Artistry, a/r/tography, ethnopoetry, ethnodrama, and other terms have since been used to variously describe mergers between social science research methods and methods used to compose and represent the literary, visual, and performing arts.

---

### Major Contributions: “Blurred Genres”

Whether in the study of linguistic anthropology, language policy, discourse studies, or multicultural education, in the last few decades researchers and theorists have drawn explicitly upon blurred genres of the arts and sciences to analyze data and present their findings. In the 1980s, these front-runners in arts-based inquiry – though not called as such – paved the way for present-day arts-based researchers to take even further risks, crossing entirely into artistic genres of fiction, poetry, painting, and drama. As writing is a vital element of research inquiry, most of the initial contributions concentrated on the use and analysis of literary art forms in the human sciences with nods to music and the visual arts.

Heath’s (1983) classic ethnography of children learning to use language in two different communities was one of the first studies in education to use a literary approach to ethnography, drawing upon narrative structures and metaphor. Lawrence-Lightfoot (1983) was the first to use the visual arts’ term “portraiture” to describe her method of combining systematic, empirical description with aesthetic expression to describe the qualities of “goodness” in high school-learning communities. Clifford and Marcus (1986) book *Writing Culture* collected the first group of essays to address the poetic and political nature of cultural representation, drawing attention to the literary and rhetorical dimensions of ethnography.



Music theory and technique have also influenced some of the most noteworthy discourse studies in education, analyzing speech for its rhythm, meter, pitch, and tone. For example, Erickson and Shultz's (1982) study of counselor and student interactions used musical notation in analysis to discover that distorted rhythms in communication were heavily associated with cultural and perceived racial differences. Erickson, who has experience in music composition and theory, used his creativity and training to enhance his ability to hear and make sense of discordance and harmony in everyday talk. Similarly, Foster's (1989) study analyzed the musical qualities of an African American teacher's classroom discourse to shed light on the qualities of her success in an urban community college classroom. In particular, Foster focused on the teacher's use of church-influenced discourse patterns such as vowel elongation, cadence manipulation, and repetition.

Finally, the visual arts have been extremely influential in the study of language and education. Eisner's (1991) work in educational connoisseurship and criticism was foremost in this regard, using examples from the visual arts to describe, interpret, evaluate, and identify explicit educational themes. Edelsky (1981) addressed the visual as well as aural aspects of transcription, identifying areas of concern as to how to best represent the authenticity and dimensionality of an observed interaction for conversational analysis.

---

## Works in Progress: "Arts-Based Inquiry" Is Born

The expansive directions of inquiry in the 1980s and early 1990s set the stage for the diversity and visibility of arts-based inquiry in the new millennium. However, arts-based research methodologies are still in conflict with established research paradigms and current political climates that emphasize and financially support traditional, scientific definitions of research. For example, in a report from US National Research Council (Shavelson and Towne 2002), Eisner's (1991) "connoisseurship" and Lawrence-Lightfoot's (1983) "portraiture" were explicitly identified in opposition to sanctioned research methods that are reliable, replicable, and generalizable in rigorously scientific ways. Despite increasing publication of arts-based research in a wide range of top-tier scholarly journals, this scholarship is rarely eligible for financial support or the basis for academic promotion. Thus, modern-day Ruth Benedicts may still exist: researchers may produce poems using authentic names, but they cannot expect professional support for doing so.

Despite plentiful deterrents, qualitative researchers in education such as Behar (2007, 2008), Ellis (2009), Isbell (2009), Saldaña (2002, 2008), and Walrath (2013) among others, too numerous to mention – confident that alternative arts-based methods are rigorous, relevant, and insightful – continue to take even greater risks, exploring new dimensions of arts-based methods that experiment at the scientific perimeter to push research questions and methodologies outward and enhance the field. There are two strands to contemporary arts-based research methodology today: those that embrace *hybrid forms* of artistic and scientific scholarship and those that produce *art for scholarship's sake*.

## Hybrid Forms

The hybrid form of “arts-based research” has been described by Barone and Eisner (2012) as “a process that uses the expressive qualities of form to convey meaning” and “raise[s] questions about important social issues, past and/or present” (p. xii–xiii). In the spirit of hybrid genres of arts-based inquiry, one of the best book-length examples is Billie Jean Isbell’s (2009) merger of fiction and scholarship in *Finding Cholita*. The hybrid form allowed Isbell to articulate the complexities of conducting fieldwork in Ayacucho, Peru, from 1975 to 1992 when the town “. . . was terrorized by the Shining Path.” Working through the genre of “fiction” or “*faction*,” Isbell (2009) was able to process the extreme violence to which she was witness:

In order to gain closure and provide a form of therapy for myself, I have turned to fiction. During the twenty years that I focused on violence, I absorbed the horrific stories told to me and found myself developing disabling infirmities. For example, as I was struggling with whether to publish the testimonies of victims, I was rendered speechless by reoccurring lesions on my tongue that required surgery. (p. vii)

Transforming ethnographic data into art allowed Isbell to render human experience in Ayacucho in ways that felt both safe and true. Similarly, Ruth Behar’s (2007) ethnographic memoir, *An Island Called Home*, is an exquisite, blurred-genre work, which turns grief and loss into art. In a partnership with photographer Humberto Mayol, Behar returned to her native Cuba to study Cuban Jews who remained after the revolution in 1959, when her own family fled to the USA. Using Mayol’s photography and Behar’s lyrical prose and poetry, the book is a blend of history, politics, anthropology, and memoir, helping readers learn about the Jewish community in Cuba – what is left of it – through Behar’s evocative narrative. Behar’s work, as well as that of Carolyn Ellis (2009), has liberated the territory of “autoethnography,” a merger between autobiography and ethnography, highlighting the extent to which the researcher foregrounds his or her own reflections and experiences in a given study. Both Behar and Ellis have also worked in collaboration with others, showcasing the ways in which arts-based research may be conducted in partnership with professional writers, photographers, and other artists.

Blurred genres of arts-based inquiry contextualize the creation of art – story, poetry, printmaking, sculpture, autobiography, ethnodrama – within their experimental science, perhaps, as Barone (2001) suggests, “because many postmodernist innovators began their careers as ethnographers and sociologists (rather than as artists, literary critics, or art theorists)” (p. 153). The more a scholar is able to simultaneously attend to empirical processes of documentation as well as to the art form’s craft, the greater the scholar’s ability may be to convey meaning in artful and reliable ways. For example, the credibility and reliability of Karen Hankins’ (2003) book, *Teaching Through the Storm*, is earned both because of Hankins’ careful teacher-research methods as well as her talent for narrating compelling accounts of classroom life. Likewise, Giles’ (2010) autoethnographic account of her process to begin the first dual-immersion charter school in Georgia showcases originality

throughout the dissertation. She presents John Dewey's theory through an imagined public-radio style interview and writes page-turning documentation of the many institutional, educational, and personal challenges presented when leading a deeply bilingual agenda for a public school. Finally, graphic artist and education scholar Sally Campbell Galman (2013) uses the comic book format to guide novice ethnographers through the qualitative data analysis processes. Even her in-text "references" include comic book-style portraits of the scholars to which she alludes.

Schol-ARTists working with blurred genres share many of the same goals in their work. First, they incorporate tools from the sciences and the arts to make new, insightful sense of data during and beyond the research project. New insights and questions take precedence over a desire for absolute answers to educational and linguistic questions. Second, these blurred-genre schol-ARTists share an explicit recognition of the self-other continuum, where the researcher is explicitly recognized as the primary instrument for documenting and interpreting knowledge from participants or from a specific context that ultimately informs the researcher about himself or herself as well. Thirdly, blurred-genre writers tend to have the goal to speak to diverse audiences both within and outside the academy. The accessible, vernacular, and aesthetic language and image are used explicitly to reach beyond the academy to larger, more diverse audiences and to engage in what Barone (2008) called "truly dialogical conversation[s] about educational possibilities" (p. 23).

## Art for Scholarship's Sake

If hybrid art forms exist between two ideal forms of "art" and "science," then *art for scholarship's sake*, as I define it, exists just beyond hybridity and plants itself more squarely in the realm of stand-alone artistry: poems, short stories, paintings, dance, and drama among other forms of artistic expression. Unlike those creating hybrid forms, most creators of art for scholarship's sake have years of advanced training in their art forms in addition to their studies in the social sciences. These scholar artists or schol-ARTists use their experiences during language education fieldwork to create pieces of art that capture the essence of their findings in emotionally penetrating ways. What distinguishes this work from *art for art's sake* is often the context in which this type of work is found and that the schol-ARTistry's content is typically grounded in the experience of data collection and analysis.

Johnny Saldaña has used his 25 years of experience as a theater artist to produce what he calls "ethnodrama," transforming fieldwork data into scripts for live theater. One of Saldaña's best-known ethnodramas is his adaptation of educational anthropologist, Henry Wolcott's research into a play called *Finding My Place: The Brad Trilogy* (Saldaña, in Wolcott 2002). In this ethnodrama, Wolcott, the researcher, and Brad, his research participant, become characters in a script that dramatizes the research findings as well as the complicated and, at times, controversial nature of the research process when the researcher becomes intimately involved with a participant.

Adrie Kusserow and Kent Maynard are two cultural anthropologists who have extensive backgrounds as poets. Both use poetry and ethnographic writing separately to share findings from their studies in different ways with different audiences. Kusserow has published her research in traditional ethnographic books and journals; regularly publishes ethnographically inspired poetry in a blurred-genre journal, *Anthropology and Humanism*; and has also published an acclaimed book of poetry, *Refuge* (Kusserow 2013), which illuminates themes from her fieldwork among “The Lost Boys,” Sudanese refugees, and their resettlement in the USA. Likewise, Maynard has placed his work in a range of venues from conventional ethnographic writing to his published poetry in the Wick Poetry Chapbook Series (Maynard 2001). Through poetry, Maynard’s research on indigenous medicine among the Kedjom peoples of the Republic of Cameroon comes alive through scintillating and unexpected language.

Stephanie Springgay is a visual artist working on projects that explore women’s subjective experiences of bodied space through community-engaged art. Springgay (2008) describes her academic curriculum vitae which includes international art shows of her work alongside published papers and conference presentations. Springgay’s two sculptures, titled *Nurse-in* and *Spillage*, were created from felted human hair, glycerin soap, and parts of a breast pump. They were designed to illuminate contemporary feminist negotiations between motherhood, breastfeeding, and work.

In Nilaja Sun’s one woman show, “No Child. . .,” she performs over 25 characters including herself, the visiting teaching artist, in ways that showcase high-poverty children “left behind” in New York City schools. She voices the enduring and debilitating effects of George W. Bush’s 2002 testing policies in contrast to the transformational power of the arts. Commissioned to perform the piece at the largest educational research convention, AERA, in 2009, her show has enthralled lay audiences nationwide (licensed to over 45 theaters nationally since 2008). Her performance and script training combined with extensive first-hand experience in New York City schools result in a breathtaking play that has garnered numerous awards including an Outer Critics Circle Award for Outstanding Solo Performance and an Obie Award.

In sum, art for scholarship’s sake is grounded in careful documentation and extensive artistic training. Trained schol-ARTists of this kind aim to imbue art with socially engaged meaning from research and imbue socially engaged research with art. Increasingly, language and education research journals such as the *Journal for Latinos and Education* and *Anthropology and Education Quarterly* formally exhibit creative reflections on fieldwork in nontraditional forms such as poetry and autobiographical prose. Other journals such as the *International Journal of Education and the Arts* and the *Journal of Curriculum and Pedagogy* feature an even wider array of representational forms and formats including musical, pictorial, and video graphic, as well as verbal and print and multimedia. There are poetry readings, performances, and arts exhibitions at major research meetings such as the AERA (through the arts-based educational research special interest group) and the

American Anthropology Association (through the society for humanistic anthropology). Examples of art for scholarship's sake in language education research share renderings of inquiry in ways that are unexpectedly memorable and charged with empirical and emotional depth.

---

## Problems and Difficulties

Due to degrees of risk – professional and personal – involved, the artistic aspects of language education research have often been implicit, seldom acknowledged as such, and have often been achieved through luck rather than purposeful development. Consequently, there is very little explicit training for current and future language researchers to practice research methods that embrace tools and techniques from the arts as well as the sciences. Without explicit training, there can be no critical community to establish what constitutes quality in arts-based research.

Another problem that arises by not creating a critical community is that there are few measurements of quality in arts-based inquiry. Without a critical community, arts-based inquiry is at risk of “anything goes” criteria, making it impossible to distinguish what is excellent from what is amateur. Accompanying the demand for arts-based approaches to inquiry must also be a call for tough critics, those who advocate alternatives but will not substitute novelty and cleverness for “instrumental utility” (Eisner 2008, p. 24). To foster a tough critical community, more arts-based educational researchers need to share the techniques and aesthetic sensibilities they use to prepare other researchers to understand, sensibly critique, and further develop arts-based approaches to scholarship.

Jane Piirto (2002) has been especially critical in regard to the question of quality in arts-based inquiry. She distinguishes arts-based exercises for personal creativity enhancement versus a higher level of schol-ARTistry that requires extensive and disciplined training. Piirto prescribes a minimum of an undergraduate minor, preferably a major, and evidence of peer-reviewed success for those who wish to make art for “high-stakes” research purposes such as dissertations, theses, or publications (p. 443). In Cahnmann (2003), I described specific ways in which the poetic arts can be used as an aesthetic tool for data collection, a creative approach to analysis, and a powerful way to represent findings. In Cahnmann (2016), I illustrate art for scholarship's sake through “Imperfect Tense,” a book of poems based on interviews with American adults studying Spanish in Mexico. My hope is that this work showcases the merger between extensive ethnographic fieldwork as well as deep study of poetic craft.

Critical of anthropologist Ruth Benedict's “cloying” attempts at verse, contemporary anthropologist, Ruth Behar (2008) suggests most scholars put their creative efforts into enhanced scholarly prose rather than complete shifts to creative genres. She advocates “poetic anthropology”:

The more important work I'm doing right now is the effort I'm making to craft a poetic anthropology. After all, we have a lot of poetic poets out there, but tell me, how many poetic anthropologists do you know? Anthropology needs poetic anthropologists. And the funny thing is that most anthropologists don't know that. Or don't want to know that. (p. 95)

Aside from quality, another tension in arts-based research concerns the metaphorical novelty of the work versus its literal utility in a climate where our audiences require answers for practice rather than an additional set of ambiguous, beautifully stated questions (Eisner 2008). Eisner contends: "Novelty is a part of creativity and creativity is important to have, but when it trumps instrumental utility . . . namely that it contribute to the enrichment of the student's educational experience, it loses its utility as a form of educational research" (pp. 16–17). Thus, an important concern for arts-based researchers in language education is how to make the process and products of schol-ARTistry valid and useful to other researchers, educators, politicians, and others wishing to benefit from the outcomes of inquiry. An exciting illustration of the power of schol-ARTistry is Walrath's (2013) graphic novel titled *Aliceheimer's: Alzheimer's Through the Looking Glass*. As a medical anthropologist who worked in the field of medical education, Walrath uses the power of graphic storytelling to recount caring for her mother, "Alice," with Alzheimer's, and engages readers to entertain different perspectives on illness and patient care. As the title suggests, there is a connection to Lewis Carroll's *Through the Looking-Glass, and What Alice Found There*, where "Wonderland" becomes a metaphor for Alzheimer's disease. Clippings from "a cheap paperback copy of Lewis Carroll's *Alice in Wonderland*" (p. 5) are collaged to create Alice's bathrobe as she goes about the mundane and magical tasks of daily living while "falling slowly down the rabbit hole" (p. 45)." Walrath's book sheds light on the intersections of the physical body with the social and political body, reframing perspectives on illness and health.

New ethical questions arise in arts-based research, concerning what constitutes "data" when personal relationships are explored, interviews being converted to performance monologues or poems, as well as how authorship is attributed, shared or not, between the originating participant and the researcher artist. Ethical concerns are not new to qualitative inquiry, but using the arts to convey information by, for, and about others requires equal scrutiny regarding the truth claims that are made.

In a political and fiscal climate insistent upon definitive, unambiguous, and generalizable answers, the challenges to ABR are not to be taken lightly. How one teaches and learns ABR practices, how one judges the quality, utility, and ethics of such work – these are just a few of the difficulties presented as creative scholars move into new ways of documenting language education. There are still more researchers writing *about* arts-based research criteria than those providing examples of what it looks like in each area of the literary, visual, and performing arts. Thus, increased numbers of researchers need to experiment with hybrid forms and art for scholarship's sake to continually refine our critical sensibilities. Increased numbers of schol-ARTists working with an established criteria for excellence help others in the field of language research discover aesthetic forms that are useful to language inquiry as well as to diverse audiences of scholars and lay people outside the

academy including teachers, administrators, politicians, and others involved in pedagogical practices and high-stakes decision making in educational contexts.

---

## Future Directions and Possibilities

Arts-based approaches to inquiry are not an either-or proposition to traditional research paradigms. Arts-based researchers in language education do no service to themselves to define their methods in opposition to more traditional approaches to inquiry. Rather, the literary, visual, and performing arts offer ways to stretch a researcher's capacities for creativity and knowing, creating a healthy synthesis of approaches to collect, analyze, and represent data in ways that paint a full picture of a heterogeneous movement to improve language education.

Among the value arts-based inquiry provides to a researcher's own imaginative thinking is also the value of sharing the process and products of arts-based research with a much larger readership than that of a typical language education study with more immediate and lasting impact. For example, sharing a poem may be a much more effective way to bring a discussion of research findings back to a group of students or teachers, than sharing a lengthy research article or book-length manuscript. Sharing a series of photographic images in the hallways of a college of education may disperse research findings to pre- and in-service teachers in more penetrating and immediate ways than any traditional text. Finally, hybrid forms and art for scholarship's sake may be more likely to find venues outside the immediate academy. For example, Jonathan Kozol's (2005) hybrid piece of journalistic ethnography found a large, influential home in *Harper's Magazine*, potentially reaching tens of thousands of readers about the conditions of under-resourced schooling in low-income areas of the urban USA.

In a recent issue of *Anthropology and Education Quarterly*, I published a series of poems based on ethnographic fieldwork among Americans pursuing Spanish as a second language in Oaxaca, Mexico (Cahnmann-Taylor 2014; Cahnmann-Taylor 2016). Based on interviews with the Americans and their teachers as well as observations of numerous Spanish languages classes, I wrote poems that were both about the "other" Americans as well as about my own family's experiences, including the following poem, "First Grade (p. 20)." The poem was written during fieldwork shortly after receiving news that poet, Maxine Kumin, had just died. Maxine had been one of my poetry teachers and had become famous for working contemporary ideas into old forms – metered verse, sonnets, villanelles. Kumin's poetry will have a long life and I wanted to honor her new formalism by writing a sonnet. Sonnets, like other formal verse structures, provide the writer some scaffolding, a perfect parallel for the second language speaker's search for footholds in a nonnative language. In this Shakespearean structure, I had 14 lines to fill in 5 rhyming stanzas: ABAB CDCD EFEF GG. The sonnet form suggests a meaningful turn will occur between lines 8 and 9 and a closing punch in the final couplet. The trained poet must be aware of these formal constraints but also forget them, writing the poem that surprises the writer, whose meaning cannot be easily contained.

The moment which triggered this poem occurred one evening a few months into my fieldwork in Mexico when my family attended a free, public screening of the children's animated film "Despicable Me 2" ["Mi Villano Favorito 2"]. I had been worried about my son's second language success at school, but that night he laughed, no *roared*, at the film's jokes in sync with the other Mexican boys and girls around us. I understood the importance of humor to break through second language literacy and the inner 6-year-old who lives in all of us as we grasp to fit into second language environments.

### **First Grade**

*In dedication to Maxine Kumin*

Two thousand three hundred nine words  
rhyme with "estar" but my son can't think  
of any for his *tarea en español*, prefers  
action figure distractions, spilling his drink,  
breaking pencils, falling from his chair—  
anything that's *not* homework until  
I offer "vomitar," to vomit and "estornudar"  
to sneeze. Pleased, he asks if "to kill"  
in Spanish would rhyme, and "to hit," and "fart,"  
— smart boy, figuring out a second tongue  
multiplies words that disconcert, courts  
deep laughter in dark theatres. So strong  
his will to be liked, to understand peers, offer  
jokes, to translate "butt" and savor what comes after.

The extent to which the poem, "First Grade," is "mine" is debatable, given that interviews with three other ex-pat families with young children informed the shaping of this poem. Thus, the poem is both mine and not mine as it sifts through the combined voices of struggle and accomplishment at any age, especially as indicated when one finally perceives humor in the second language. The extent to which the poem succeeds in the quality of its form or its ability to arouse discussions about the social issue of second language acquisition is debatable. Likewise, I question the poem's utility — what work can a poem actually do? I continue to discuss ethical questions that arise in poetic inquiry — to whom does the poem belong when it integrates the voice of the observed or interviewed Other? Are there actually 2,309 words that rhyme with "estar"? Does the poem advocate we teach taboo language to second language learners? What difference is there between what is literally true and what rings true in research and in poetry?

The origin of the word "stanza" comes from the Latin for "stay" or "abode," a little room where one might rest. Perhaps, the best outcome an (auto)ethnographic poem like "First Grade" can offer language education readers is a little room to rest, to contemplate what is both playful and painful in acquiring another language. An ethnographic poem will not likely be successful in all arts-based research missions, but it does help the researcher employ aesthetic as well as intellectual abilities, to be surprised by fieldwork images and conversations and their potential insight to our fields of inquiry.



Researchers in language education cannot lose by acquiring and applying techniques employed by arts-based researchers. We must assume an audience for our work; one that longs for fresh language and imagery to describe the indescribable emotional and intellectual experiences in and beyond language education contexts. We may not all be poets, dancers, or painters, but we can all draw on the arts to craft poetic discourse analysis or artful case studies – renderings that realize the heights of artistic as well as scholarly potential, challenging the academic marginality of our work.

We might decide to read more poetry, take a dance class, and thus find ourselves taking more risks in the ways we approach our research methodology – whether this means incorporating sketches of a field site in our notebooks, writing “data poems” from interview transcripts, or creating a scripted dialogue between the “characters” of influential theorists such as Bakhtin and Vygotsky wrestling with the resource-strapped conditions of today’s public schools. My hope is for language education researchers to explore arts-based research methodologies mentioned here as well as others included in the second edition of our arts-based research book (Cahnmann-Taylor & Siegesmund, 2008; *In Press*), as a means to add more joy, meaning, and impact to our work.

---

## Cross-References

- ▶ [Ethnography and Language Education](#)
- ▶ [Linguistic Ethnography](#)

---

## References

- Barone, T. (2001). *Touching eternity: The enduring outcomes of teaching*. New York: Teachers College Press.
- Barone, T. (2008). How arts based research can change minds. In M. Cahnmann & R. Siegesmund (Eds.), *Arts-based inquiry in diverse learning communities*. Mahwah: Lawrence Erlbaum Associates/Taylor & Francis Group.
- Barone, T., & Eisner, E. W. (2012). *Arts-based research*. Los Angeles: Sage.
- Behar, R. (2007). *Translated woman: Crossing the border with Esperanza's story*. Boston: Beacon.
- Behar, R. (2008). *An island called home: Returning to Jewish Cuba*. New Brunswick: Rutgers University Press.
- Benedict, R. (1934). *Patterns of culture*. Boston: Houghton Mifflin Company.
- Brady, I. (2000). Anthropological poetics. In N. K. Denzin & Y. S. Lincoln (Eds.), *Handbook of qualitative research* (2nd ed.). London: Sage.
- Cahnmann, M. (2003). The craft, practice, and possibility of poetry in educational research. *Educational Researcher*, 32(3), 29–36.
- Cahnmann-Taylor, M. (2014). Living the (Im)perfect American Sueño [Dream]: Adult Spanish language study in Mexico. *Anthropology & Education Quarterly*, 45(4), 409–413.
- Cahnmann-Taylor, M. (2016). *Imperfect tense*. San Pedro: Whitepoint Press.
- Cahnmann-Taylor, M. & Siegesmund, R. (In Press). *Arts-Based Research in Education: Foundations for Practice* (2nd edition). London: Routledge.
- Cahnmann-Taylor, M. & Siegesmund, R. (2008). *Arts-Based Research in Education: Foundations for Practice*. London: Routledge.

- Clifford, J., & Marcus, G. E. (1986). *Writing culture: The poetics and politics of ethnography*. Berkeley: University of California Press.
- Dewey, J. (1934). *Art as experience*. New York: Minton Balch & Company.
- Edelsky, C. (1981). Who's got the floor? *Language in Society*, 10(3), 383–421.
- Eisner, E. W. (1991). *The enlightened eye: Qualitative inquiry and the enhancement of educational practice*. Toronto: Macmillan Publication & Co.
- Eisner, E. W. (2008). Persistent tensions in arts based research. In M. Cahmann & R. Siegesmund (Eds.), *Arts-based inquiry in diverse learning communities*. Mahwah: Lawrence Erlbaum Associates/Taylor & Francis Group.
- Ellis, C. (2009). Telling tales on neighbors: Ethics in two voices. *International Review of Qualitative Research*, 2(1), 3–28.
- Erickson, F., & Shultz, J. (1982). *The counselor as gatekeeper: Social interaction in interview*. New York: Academic.
- Foster, M. (1989). It's cookin' now: A performance analysis of the speech events of a Black teacher in an urban community college. *Language in Society*, 18, 1–29.
- Galman, S. C. (2013). *The good, the bad, and the data: Shane the lone ethnographer's basic guide to qualitative data analysis*. Walnut Creek: Left Coast Press.
- Giles, D. P. (2010). "Unchartered" territory: An autoethnographic perspective on establishing Georgia's first public two-way immersion school. Unpublished doctoral dissertation, University of Georgia, Athens.
- Hankins, K. H. (2003). Teaching through the storm: A journal of hope. In M. Cochran-Smith & S. L. Lytle (Eds.), *Practitioner inquiry series*. New York: Teachers College Press.
- Heath, S. B. (1983). *Ways with words: Language, life, and work in communities and classrooms*. Cambridge: Cambridge University Press.
- Hymes, D. H. (1964). Introduction: Toward ethnographies of communication. *American Anthropologist*, 66(6), 1–34.
- Isbell, B. J. (2009). *Finding Cholita*. Chicago: University of Illinois Press.
- Kozol, J. (2005). Still separate, still unequal: America's educational apartheid. *Harper's Magazine*, 311(1864), 41–54.
- Kusserow, A. (2013). *Refuge*. Rochester: Boa Editions.
- Lawrence-Lightfoot, S. (1983). *The good high school: Portraits of character and culture*. New York: Basic Books.
- Maynard, K. (2001). *Sunk like God behind the house, wick chapbook series*. London: Kent State University Press.
- Neilsen, L. (2005). *Homepage*. <http://www.iirc.mcgill.ca/collaborators/collabln.html>. Accessed 6 Mar 2005.
- Piirto, J. (2002). The question of quality and qualifications: Writing inferior poems as qualitative research. *Qualitative Inquiry*, 15(4), 431–446.
- Saldaña, J. (2002). Finding my place: The Brad trilogy. In H. F. Wolcott (Ed.), *Sneaky kid and its aftermath: Ethnics and intimacy in fieldwork*. Walnut Creek: Altamira Press.
- Saldaña, J. (2008). The drama and poetry of qualitative method. In M. Cahmann & R. Siegesmund (Eds.), *Arts-based inquiry in diverse learning communities*. Mahwah: Lawrence Erlbaum Associates/Taylor & Francis Group.
- Shavelson, R. J., & Towne, L. (2002). *Scientific research in education*. Washington, DC: National Academy Press.
- Springgay, S. (2008). Nurse-in: Breastfeeding and a/r/tographical research. In M. Cahmann & R. Siegesmund (Eds.), *Arts-based inquiry in diverse learning communities*. Mahwah: Lawrence Erlbaum Associates/Taylor & Francis Group.
- Walrath, D. (2016). *Aliceheimer's: Alzheimer's through the looking glass*. Yerevan: Harvest. University Park, PA: Penn State University Press.
- Wolcott, H. F. (2002). *Sneaky kid and its aftermath: Ethics and intimacy in fieldwork*. Walnut Creek: Altamira Press.

---

# Researching Timescales in Language and Education

Elaine Allard

---

## Abstract

This chapter provides an overview of language and education research that incorporates explicit attention to timescales into its theoretical frameworks and research methodologies. A timescale is “the characteristic spatiotemporal envelope within which a process happens” (Wortham 2012; Lemke 2000, 2001, 2002) proposed that attending to timescales is an important component of understanding complex human processes, such as identity and language development. This chapter outlines Lemke’s theory and follows its applications in linguistic anthropological studies of social and academic identification and recent approaches to the study of language development and use. The studies reviewed in this chapter pay explicit attention to temporal aspects of their questions of interest, considering, for instance, how short-term interactions such as classroom discussions contribute to longer-term linguistic, academic, and identity development and how phenomena developed over long periods or events from distant historical moments influence short-term exchanges in the present.

---

## Keywords

Timescales • Social identification • Ethnography • Language development • Discourse analysis

## Contents

Introduction .....	368
Early Developments: Theorizing Timescales in Educational Research .....	368
Proposed Topics and Methods .....	370
Major Contributions: Timescales and Social Identification .....	370
Work in Progress: Timescales and Language Development .....	373

---

E. Allard (✉)

Educational Studies, Swarthmore College, Swarthmore, PA, USA

e-mail: [eallard1@swarthmore.edu](mailto:eallard1@swarthmore.edu)

---

Problems and Difficulties .....	375
Future Directions .....	376
Cross-References .....	377
Related Articles in the Encyclopedia of Language and Education .....	377
References .....	377

---

## Introduction

The past 15 years have heralded increased attention among some researchers of language and education to the temporal aspects of their questions of interest. A subset of linguistic anthropologists of education, ethnographers of literacy, and investigators of second language development have begun to investigate how time figures in social and academic identification and language learning. How does a single class session or a brief conversational exchange contribute to longer-term linguistic, academic, or identity development? How do phenomena developed over decades or centuries influence short-term exchanges in the present? How can attention to these temporal relationships better illuminate questions of learning? The literature reviewed below speaks to these and related questions.

This chapter provides an overview of language and education research that incorporates explicit attention to *timescales* into its theoretical and methodological approach. A timescale is “the characteristic spatiotemporal envelope within which a process happens” (Wortham 2012, p. 133). Attention to timescales within the study of education can be traced back principally to Jay Lemke’s discussions of ecosocial systems (2000, 2001, 2002). Because of the centrality of his work, I begin by outlining the most widely applied components of Lemke’s theory of timescales for educational research. In the subsequent section, I discuss major insights from linguistic anthropological studies of academic and social identification and provide select details on a few major studies that elucidate these points. A brief discussion of how timescales figure in recent studies of second language development follows. The chapter ends with a discussion of the challenges to researching timescales and some promising approaches to refining empirical approaches.

---

## Early Developments: Theorizing Timescales in Educational Research

Lemke (2000, 2001) draws attention to the fact that there are various temporal scales during and across which all processes occur, from chemical processes that take milliseconds to cosmological processes that occur over billions of years. Educational processes occupy a narrower, though still quite wide, range of timescales: from the seconds occupied by an individual student or teacher’s utterance, the months it takes to complete a semester, the many decades that constitute an individual’s lifetime

educational development, to the hundreds of years it can take for educational institutions to change, and so forth. Lemke proposes that to understand any kind of human activity, including those related to education, researchers must identify relevant processes at multiple timescales and investigate how those processes interact with others at different scales.

Lemke proposes a few important ways in which processes at various scales relate to one another. The first relates to emergence and constraint. He explains that what can happen in a process at any given timescale is made possible by the processes going on at the shorter, faster timescale immediately below it and, at the same time, is constrained by those processes at the longer, slower scale above it. Take, for example, a given class session in one teacher's classroom. What is likely to happen in that one, say 40 min, lesson is influenced by patterns of interaction that have developed over longer timescales – over that week, month, and school year, by ways of organizing classroom instruction at that particular school over its decades-long history, by cultural patterns of schooling that have developed over hundreds of years. Each of these scales constrains the one below it, shaping what is likely to happen at the lower, shorter scale. At the same time, what happens in that one class session is also made possible by practices at shorter timescales than the focal 40-min class period, by minutes-long interactions and seconds-long utterances that may either contribute to longer-standing patterns or introduce unexpected ones. Likewise, new patterns that emerge in that class session make possible changes in the way that classroom will operate during that particular week, and so forth, up the scalar hierarchy.

The second way in which various scales relate is when activities at distant timescales produce effects on one another, when a short-timescale process has a rippling effect into longer timescales or vice versa. Lemke (2000) claims that *heterochrony*, “in which a long timescale phenomenon produces an effect in a much shorter timescale activity” is “the basis for human social organization across timescales” (p. 280). Heterochrony is most obvious in “semiotic objects” which “carr[y] significant information across time and space” in that they recall meanings developed on a different timescale, while they are also used in the present moment (Lemke 2001, p. 21). The notebook a student refers to when her teacher asks a question to the class provides an example, since the notes were written days or weeks before but are being read and interpreted in response to the teacher's question in that moment (Lemke 2000, p. 281). Human beings themselves also function in this way, as Lemke (2002) explains, “[A 12 year-old child] may be 12 by the calibrations of calendars, but as a member of the community he is dynamically heterochronous, some mix of every age he's already been, and every age he's learned to cope with, and many ages he's begun to understand and imagine and model” (p. 81). To consider any phenomenon at only one timescale, therefore, is to miss a good deal of what is relevant to it. Because human activity, including educational processes, are so complex, an adequate account of them must attend to multiple timescales and to the interrelationships between processes at different scales, including emergence, constraint, and heterochrony.

---

## Proposed Topics and Methods

While Lemke claims that attention to timescales would benefit the study of any social process, he notes the particular potential of this framework in understanding identity formation, classroom learning (2000, 2001), and language development (2002). While we know a good deal more about short-term social processes, Lemke argues that we know much less about longer-scale processes that occur over multiple days, months, years, or more (2000, p. 287). Access to these longer-timescale activities is key because human processes such as identity formation, changes in habits of reasoning, and language development all occur over longer timescales (Lemke 2000, 2002).

Lemke proposes that gaining access to these longer timescales would require borrowing methods from historians, archivists, and biographers, who regularly engage with timescales of decades or longer (2000). This suggestion would entail the wider use of oral histories, life history interviews, archival research, and deep engagement with secondary historical source documents. In addition, in order to understand societal processes and changes, teams of researchers would be necessary, as well as a “self-sustaining institution that would last long enough to observe major historical change in the system” (2000, p. 288), such that multiple generations of researchers could observe and analyze longer-timescale processes. Lemke suggests that modern technologies and networks may hold some promise for the kinds of collaboration and long-term corpus building that he envisions here.

---

## Major Contributions: Timescales and Social Identification

Much of the scholarship that employs the concept of timescales, as Lemke outlined it, focuses on social identification, or “the process through which individuals and groups become identified as publically recognizable categories of people” (Wortham 2004, p. 716). For example, studies of social identification may examine how a child becomes identified as a “nerd,” a “jock,” a “good reader,” or any multitude of widely circulating and/or locally relevant identities. This literature focuses on how social identification happens over time in classrooms, through the language that others use to talk about and to particular individuals or groups. In many cases, researchers in this area are also interested in the relationship between social identification and academic learning (Bell et al. 2012; Polman and Miller 2010; Wortham 2006, 2008) and, in particular, literacy (Bartlett 2007; Burgess and Ivancic 2010; Compton-Lilly 2011; Roswell and Pahl 2007). In this section, I highlight key findings that have come out of this work, followed by empirical examples that illustrate these major insights.

By attending to timescales in the study of social and academic identification, researchers have come to three principal conclusions and related methodological implications. First, many of these studies illustrate empirically that social identification occurs at multiple timescales, from speech events to prolonged social and

academic interaction over months or years. Therefore, it must be studied at these various scales, with attention to the ways in which shorter-timescale events can develop into more durable patterns at longer scales (Worham 2006, 2008). Second, and relatedly, this scholarship has shown that social identification, including students' academic and literate identifications, can change (sometimes drastically) over time and that it is therefore crucial to study such identification over the long term, rather than relying exclusively on shorter-term analyses (Bartlett 2007; Compton-Lilly 2011; Worham and Rhodes 2012). Third, this body of work has demonstrated how, in making sense of themselves and others, people draw on identity categories, discourses, and other resources from multiple timescales, both within and far beyond the scale of their own lifetimes (Compton-Lilly 2011; Hall et al. 2010; Pahl 2007; Worham 2006). These multiple timescales are simultaneously invoked in talk and texts (Bell et al. 2012; Brown et al. 2005; Worham 2006). Together, these studies show that attention to multiple timescales can lead to more accurate and nuanced analyses than attention to only one scale (Worham and Rhodes 2012; Zhang and Sun 2011) and, in particular, can provide a more precise alternative to "micro" and "macro" explanations of emergence and constraint common in social theory (Hult 2010; Worham 2006, 2012; Worham and Rhodes 2012). The following examples illustrate these key findings.

Pioneering work by Worham (e.g., 2006, 2008) illustrates how social identification occurs on multiple timescales, in single interactions as well through a trajectory of interactions over time that "sediment" social identification, or result in the formation of longer-lasting identities. Working with video data from a middle-school science classroom (2008), for example, he analyzed 2 months of recorded interaction to show how one student, Philip, becomes understood as both a good student and a low-status peer. Worham illustrates how one particular speech event, in which Philip grabs a female lab partner's wrist, marks a pivotal moment in Philip's identification as an academic leader as well as a social undesirable. Through his words and action, Philip asserts his academic authority by taking control of the experiment. At the same time, however, his lab mate's strongly negative reaction to his touch positions Phillip as an undesirable peer. Through a close analysis of short segments of recorded interaction between Philip and his lab partners, Worham goes on to show how subsequent events over the following months make these particular identifications of Philip enduring, even when other isolated interactions offer divergent possibilities.

In his study of a high school Paideia classroom (2006), Worham combined discourse analysis of 50 recorded class sessions over an academic year with ethnographic observations and interviews. His analyses revealed that students and teachers drew upon identity categories, intellectual positions, and cognitive models from various timescales in their classroom discussions. For example, in minutes-long classroom interactions, teachers and students invoked sociohistorical categories, developed over decades and centuries of "unpromising boys" and "promising girls," identity models from the curriculum (such as Aristotle's "beast," conceived of over 2000 years before the study took place), and local versions of these models that developed over weeks and months in the classroom. Worham illustrates how two

students, Maurice and Tyisha, become identified as outsiders from the group over time, in part through the heterochronous “participant examples” teachers and students used to discuss curricular themes. His account of this interdependent process of social identification and academic learning illustrates the relevance of a wide range of timescales in social identification as well as the ways in which short, “microgenetic” timescale events (such as individual classroom discussions) contribute to longer-timescale social identification.

Following Wortham, Bartlett (2007) describes a case in which a student’s social identification can change dramatically over time and space, thus underscoring the importance of analyzing social identification over longer intervals. Bartlett shows how over the course of 4 years, the social identification of one bilingual high school student, María, shifted drastically. María went from being described as a stigmatized SIFE (student with interrupted formal education) to being understood by her teachers as a hard-working, successful student. As she made choices that influenced the way her teachers viewed her, María drew upon a local version of school success that reflected the more widely circulating, longer-timescale, sociohistorical narrative of immigrant opportunity in the USA. As María’s identification shifted, so too did the possibilities she had for learning English and academic content, as she was able to move through the beginner classes into those that afforded richer opportunities for language and content learning. During the 4-year study, Bartlett’s research team collected field notes from multiple classrooms and “recorded and reported speech” via audio-recorded interviews and participant observation. Bartlett notes that her decision not to audio record classroom interaction meant that she was unable to conduct discourse analyses like Wortham (2006); however, her team’s longitudinal, multiple-classroom approach allowed her to see how this particular student’s identity changed across both time and classroom contexts.

Compton-Lilly (2011), in an even longer-scale project than Bartlett’s, tracked the discourses around literacy and schooling that several children and their family members drew upon, adopted, and adapted over an 8-year period. Her data include parent and student interviews, field notes, classroom assessments, and students’ writing samples. She employed a method of “periodic restudy” in which she collected data at regular intervals (in 1st, 4th/5th, and 7th/8th grades). Compton-Lilly examines the discourses employed by one student, Alicia, and her mother and siblings during and after recorded interviews, with a particular focus on how multiple timescales are invoked in their talk about literacy and schooling. She shows that family members accessed discourses from what she calls “historical,” “family,” and “ongoing” timescales to make sense of their experiences, as when Alicia’s mother invoked historical events, childhood memories, and ongoing teacher comments in describing why she advocated for her children’s education. In this way, Compton-Lilly emphasizes the interrelations between events and processes at various timescales (see also Hall et al. 2010; Wortham 2006). Pahl (2007) and Roswell and Pahl (2007) demonstrate similar findings about layered timescales, though through a focus on written texts as semiotic objects, which they argue can be analyzed to reveal the identities of the text-makers at one moment in time (Roswell and Pahl 2007).



Through their attention to time as part of their theoretical and methodological approaches, these studies bring us closer to understanding the mechanisms through which students become identified and come to inhabit social and academic identities. Unsurprisingly, the methods used to arrive at these central findings were ethnographic, discourse analytic, and, in most cases, longitudinal. As Pahl (2007) notes, ethnographers are uniquely positioned to attend to various timescales because of their methodologies and the length of their studies. Ethnographic methods typically afford access to some recorded speech (e.g., classroom discourse recordings, interviews), produced at short timescales (minutes to hours), as well as to developments over longer timescales (months to years). Furthermore, ethnographers develop deep knowledge of their contexts that can attune them to relevant timescale processes beyond the span of their actual studies. Researchers attuned to timescales in understanding educational phenomena also look for dynamic interactions across data produced at disparate scales. Such analyses go beyond reliance on the broad categories of “macro” and “micro” to explain their phenomena of study and instead identify more specific ranges during which ideas or discourses circulate, including intermediate-level processes (such as the classroom category of “beast” that developed over weeks and months in Wortham’s Paideia classroom or the “family”-level timescale in Compton-Lilly’s work) that are often left out of micro/macro accounts (Hult 2010; Wortham 2006, 2012; Wortham and Rhodes 2012). These studies also highlight the ways in which emergence and constraint happen at many different scales, rather than only at the individual or the societal levels (see Wortham 2012; Wortham and Rhodes 2012 for extensive discussion of this issue).

Attending to timescales in the investigation of educational processes, therefore, calls for the integrated use of such methods as ethnography and discourse analysis as well as for more protracted studies, since all of these methods provide access to different timescale processes. In addition to systematic data collection at multiple scales, it requires analysis of data for relationships across disparate scales and for influences of longer-timescale processes to which the analyst does not have direct access. Doing so entails a step away from the all-too-common siloing of the historical from the ethnographic and the discourse analytic in educational research. Instead, researching timescales in education requires researchers to attend carefully to change over time and to dynamic interactions across scales that help to explain their questions of interest.

---

## **Work in Progress: Timescales and Language Development**

In addition to the attention timescales have received in studies of social identification, another noteworthy strand of research uses timescales as part of a theoretical framework of second language development and use (Kramsch 2008; Larsen-Freeman and Cameron 2008; Steffensen and Fill 2014). A call to research multiple timescales appears in several newer approaches to studying language and language development, including dynamic systems (e.g., vanGeert 2008), complexity theory (e.g., Larsen-Freeman and Cameron 2008), and ecolinguistics (e.g., Kramsch 2008;

Steffensen and Fill 2014). All of these approaches view language and language development as complex, dynamic, and emergent systems.

According to complexity theory and dynamic systems theory, such systems are composed of many different component parts, change over time, are nonlinear in their development, and are emergent, in that components on lower levels of the system interact to “produce patterned behavior at various levels over time” (Churchill 2007, p. 342). Theorists approaching language and language development from this perspective eschew reductionism in their data collection and analysis. Rather than isolating variables and researching their effects, they instead seek to understand “how the interaction of the parts gives rise to new patterns of behavior” (Larsen-Freeman and Cameron 2008, p. 201). Timescales are relevant to these approaches because the nested subsystems within any complex system operate at varying timescales. Steffensen and Fill (2014) explain:

For instance, when we engage in verbal activity, we integrate the fast timescales of synaptic activity and interbodily dynamics (bodily and vocal gestures) with the longer, slower timescales of sociocultural dynamics (e.g. the logics of the arena in which we engage in social interactions) and the historical resources of social and symbolic patterns and norms (Thibault 2011; Steffensen 2011). Thus, saying that language is caused by brains, or microsocial norms, or human interactions, or phenomenological experiences, is an unwarranted reduction of a multifaceted reality. (pp. 14–15)

From this perspective, it is necessary to consider as many aspects of the system as possible, at the multiple timescales at which these component processes occur, in order to understand a complex process like language development. However, researchers using these approaches also recognize the “unknowableness” of complex systems, explaining that it is impossible to fully describe the changing, emergent, and nonlinear behavior and interactions between component processes within the system (Larsen-Freeman and Cameron 2008).

Drawing on complexity theory, emergentist theories of language acquisition, and postmodern theories of language use, Kramsch (2008) outlines the components of an ecological theory of language development and use. She explains that timescales are relevant to that approach because “the meanings expressed through language occur on multiple timescales” (p. 391) and “utterances. . .recreate environments from other scales of space and time, produce fractals of patterns from one timescale to another” (p. 401). That is, language is both uttered in the present moment and contains multiple layers of meaning, developed at different temporal (and spatial) scales, only some of which are invoked by the participants, though others are also present (Bakhtin 1981; Blackledge and Creese 2014; Blommaert 2005, as cited in Kramsch 2008, p. 393). Language can also reproduce patterns that recur at multiple scales (see also vanGeert 2008). Kramsch (2008) provides a fascinating empirical example in her analysis of spoken interaction between a Yucatecan immigrant, his literacy teacher, and two Asian merchants. Using a discourse-analytic approach, she points to moments in the conversation where participations invoke multiple timescales and shows how examining connected timescales in language use allows the analyst to capture aspects of linguistic interaction that would be otherwise invisible.

In addition to discourse-analytic and ethnographic approaches, other methodologies have been proposed to understand processes occurring at multiple timescales in language development. Larsen-Freeman and Cameron (2008) describe several newer methodologies that are especially useful for researching complex systems, two of which specifically target temporal aspects in the study of complexity. The first is the longitudinal, case-study, time series approach, which they state, “enables connections to be made across levels and timescales” (p. 208). In this methodology, it is necessary to identify both the timescale and the rate at which some particular change of interest occurs in order to determine how long a study to conduct as well as how often to sample. At the other end of the spectrum, *microdevelopment* can illuminate complex processes at shorter timescales. Studies using a microdevelopment approach produce dense corpora of data collected over short periods of time, while study participants are engaged in some activity (Granott and Parziale 2002). For example, Gelman and colleagues (2002) analyzed the real-time development of scientific knowledge and English as a second language (ESL) in a high school “science into ESL” program. By coding and conducting quantitative analyses of students’ science journals, the authors were able to see evidence of learning in process. A microdevelopment approach promises the possibility to directly observe moments of change that can illuminate longer-timescale development and can provide insights into “the how of [language] development” (Thelen and Corbetta 2002, as cited in Larsen-Freeman and Cameron 2008, p. 208).

Broadly, incorporating attention to timescales in research on second language development calls for an expansion of focus, away from studying individual sounds or structures, to investigating the ways in which any particular aspect of language develops within the broader system, not only of the language itself, but also of the environment in which that development happens. The timescales at which these component processes occur are but one aspect to attend to within these complex systems. More specifically, adopting a timescales lens in the study of language development might also entail identifying the timescales under which particular linguistic structures of interest develop, designing longitudinal studies that document change over time, collecting data on the same phenomena at multiple scales, or attending to relevant scales that are not available for direct data collection, but which nevertheless shed light on language use and are accessible to the analyst via discourse-analytic and ethnographic analyses (Kramersch 2008).

---

## Problems and Difficulties

As reviewed above, researching timescales in language and education offers unique insights into complex processes such as social identification and language development. However, attending to multiple timescales also poses real methodological challenges. Lemke (2000) noted that the kinds of fine-grained analyses that are possible at the interactional or activity level become impossible as the scale lengthens, because of the logistical difficulties of collecting and analyzing that quantity of data over extended periods of time. Furthermore, as the temporal scale

expands, so usually does the spatial scale, producing an untenable range of research sites. Longer-timescale work is also difficult because of the limits imposed by the length of the typical research project and the career of a single analyst.

In addition, if there are an infinite number of timescales (Lemke 2000), and complex processes and systems are ultimately “unknowable” (Larsen-Freeman and Cameron 2008), then clearly no analyst can hope to attend to all possible timescales acting on a focal phenomenon. Furthermore, the theory that only certain scales are “within the grasp of” interactional participants even when other “layers of historicity” are also present (Bakhtin, 1981; Blommaert 2005, as cited in Kramsch 2008, p. 392) presents another question. Should researchers focus primarily on those scales that have been directly invoked by participants or attempt to also elucidate those that are invisible to participants? In either case, a methodology for determining which scales are relevant is necessary (Wortham 2012; Wortham and Rhodes 2012). Researchers have always had to make choices about how to focus their research and about what balance to strike between emic and etic perspectives. However, as the range of possible foci expands, as it must do when attending to multiple timescales, a proposal for guiding these analytic choices becomes increasingly important.

---

## Future Directions

Partial solutions to these difficulties have been proposed. With regard to the challenges of collecting data at long timescales, the method of periodic restudy employed by Compton-Lilly (2011) and the longitudinal, case-study, time series approach, for example, both offer systematic approaches to collecting manageable amounts of data over longer timescales. Incorporating such methodologies over timescales longer than a decade, however, would very likely require a multi-researcher, multi-sited, corpus-building approach.

In cases where the issue is not data collection but a question of what timescales are relevant to analysis, recent attention to spatial and temporal scales in sociolinguistics and anthropology offer promising directions. Blommaert (2010) proposes attending to moments of “scale jumping” in discourse, when norms, expectations, ideas, and other phenomena from higher-level temporal and spatial scales are referred to by participants. He draws attention to the fact that these moves are often performed as power tactics, since some actors have more access to higher-level scales than others and provides the example of the doctor who scale jumps when he switches from vernacular to medical jargon in discussion with a patient, a jump which many patients would be unable to make (p. 36). Collins (2012) similarly argues that scales do not have a priori relevance but instead are produced in real-time interaction by participants. Like Blommaert, he notes that “scaling” can be rife with power dynamics, as when certain scales carry greater authority than others. In one example from a school context, he shows how a tutor’s use of Spanish with an immigrant child “licenses a bilingual local scale” by legitimating Spanish as appropriate in this learning context. However, when her teacher later declares that she doesn’t want the tutor speaking to this child in Spanish, she references a wider-scale

English-only prohibition that has greater authority at school (p. 204). Lempert (2012) goes further, in stressing a need to account for how scale jumping happens. He exhorts analysts to investigate, rather than presume, the scale of any given interaction, not only those scales that are invoked but even the scale of the focal phenomenon. He states, “despite the inexhaustible scalar complexity that can (nb. a potential) be discovered and exploited, there is no guarantee that scale matters – in the sense of being *registered* by interactants in some respect or capacity and pragmatically *consequential* in discursive interaction” (p. 153, emphasis in original). Future work in this area should continue to articulate an empirical approach to determining such registering and consequence, specifically articulating *how* analysts can identify timescales that are “within the grasp” of the participants, as well as those that are not, but which may still be important in understanding the focal phenomenon.

While the authors reviewed in this chapter have taken up Lemke’s (2000, 2001, 2002) call to attend to multiple timescales in researching complex educational and social processes, his methodological recommendations have not been widely applied. In particular, his exhortation to adopt methodologies from historians and biographers, such as archival research, oral histories, and others, to conduct research in teams comprised of analysts with a wide range of perspectives and positionalities and to develop longitudinal corpora of interactional data that can be analyzed over the long term by multiple researchers (2000) all still hold much promise for researchers interested in understanding the temporal aspects of complex systems, including the many of interest to researchers of language and education.

---

## Cross-References

- ▶ [Discourse Analysis in Educational Research](#)
- ▶ [Ethnography and Language Education](#)
- ▶ [Linguistic Ethnography](#)
- ▶ [Researching Identity in Language and Education](#)

---

## Related Articles in the Encyclopedia of Language and Education

Sune Vork Steffensen and Claire Kramsch: [The Ecology of Second Language Acquisition and Socialization](#). In Volume: Language Socialization

---

## References

- Bahktin, M. M. (1981). Discourse in the novel. In M. Holist (Ed.), *The dialogic imagination: Four essays* (pp. 259–422) (C. Emerson & M. Holist, Trans.). Austin: University of Texas Press.
- Bartlett, L. (2007). Bilingual literacies, social identification, and educational trajectories. *Linguistics and Education, 18*, 215–231.

- Bell, P., Tzou, C., Bricker, L., & Baines, A. D. (2012). Learning in diversities of structures of social practice: Accounting for how, why and where people learn science. *Human Development*, *55*, 269–284.
- Blackledge, A., & Creese, A. (2014). *Heteroglossia as practice and pedagogy*. Dordrecht: Springer.
- Blommaert, J. (2005). *Discourse*. Cambridge: Cambridge University Press.
- Blommaert, J. (2010). *The sociolinguistics of globalization*. New York: Cambridge University Press.
- Brown, B. A., Reveles, J. M., & Kelly, G. J. (2005). Scientific literacy and discursive identity: A theoretical framework for understanding science learning. *Science Education*, *89*(5), 779–802.
- Burgess, A., & Ivanic, R. (2010). Writing and being written: Issues of identity across timescales. *Written Communication*, *27*(2), 228–255.
- Churchill, E. (2007). A dynamic systems account of learning a word: From ecology to form relations. *Applied Linguistics*, *29*(3), 339–358.
- Collins, J. (2012). Migration, sociolinguistic scale, and educational reproduction. *Anthropology & Education Quarterly*, *43*(2), 192–213.
- Compton-Lilly, C. (2011). Literacy and schooling in one family across time. *Research in the Teaching of English*, *45*(3), 224–251.
- Gelman, R., Romo, L., & Francis, W. S. (2002). Notebooks as windows on learning: The case of a science-into-ESL program. In N. Granott & J. Parziale (Eds.), *Microdevelopment: Transition processes in development and learning* (Vol. 7, pp. 269–293). Cambridge: Cambridge University Press.
- Granott, N., & Parziale, J. (2002). *Micro development: Transition processes in development and learning*. New York: Cambridge University Press.
- Hall, L., Johnson, A., Juzwik, M., Wortham, S., & Mosley, M. (2010). Teacher identity in the context of literacy teaching: Three explorations of classroom positioning and interaction in secondary schools. *Teaching and Teacher Education*, *26*, 234–243.
- Hult, F. M. (2010). Analysis of language policy discourses across the scales of space and time. *International Journal of the Sociology of Language*, *202*, 7–24.
- Kramsch, C. (2008). Ecological perspectives on foreign language education. *Language Teaching*, *41*(3), 389–408.
- Larsen-Freeman, D., & Cameron, L. (2008). Research methodology on language development from a complex systems perspective. *Modern Language Journal*, *92*(2), 200–213.
- Lemke, J. (2000). Across the scales of time: Artifacts, activities, and meanings in ecosocial systems. *Mind, Culture, & Activity*, *7*(4), 273–290.
- Lemke, J. (2001). The long and short of it: Comments on multiple timescale studies of human activity. *The Journal of the Learning Sciences*, *10*(1/2), 17–26.
- Lemke, J. (2002). Multiple timescales in the social ecology of learning. In C. Kramsch (Ed.), *Language acquisition and language socialization: Ecological perspectives* (pp. 68–87). London: Continuum.
- Lempert, M. (2012). Interaction rescaled: How monastic debate became a diasporic pedagogy. *Anthropology & Education Quarterly*, *43*(2), 138–156.
- Pahl, K. (2007). Timescales and ethnography: Understanding a child's meaning-making across three sites, a home, a classroom and a family literacy class. *Ethnography and Education*, *2*(2), 175–190.
- Polman, J. L., & Miller, D. (2010). Changing stories: Trajectories of identification among African American youth in a science outreach apprenticeship. *American Educational Research Journal*, *47*(4), 879–918.
- Roswell, J., & Pahl, K. (2007). Sedimented identities in texts: Instances of practice. *Reading Research Quarterly*, *42*(3), 388–404.
- Steffensen, S. V. (2011). Beyond mind: An extended ecology of languaging. In S. J. Cowley (Ed.), *Distributed language* (pp. 185–210). Amsterdam: John Benjamins.
- Steffensen, S. V., & Fill, A. (2014). Ecolinguistics: The state of the art and future horizons. *Language Sciences*, *41*, 6–25.

- Thelen, E., & Corbetta, D. (2002). Micro development and dynamic Systems: Applications to infant motor development. In N. Granott & J. Parziale (Eds.), *Microdevelopment: Transition processes in development and learning* (Vol. 7, pp. 59–79). Cambridge: Cambridge University Press.
- Thibault, P. J. (2011). First order languaging dynamics and second-order language: The distributed language view. *Ecological Psychology, 23*, 210–245.
- van Geert, P. (2008). The dynamic systems approach in the study of L1 and L2 acquisition: An introduction. *Modern Language Journal, 92*(2), 179–199.
- Wortham, S. (2004). The interdependence of social identification and learning. *American Educational Research Journal, 41*(3), 715–750.
- Wortham, S. (2006). *Learning identity: The joint emergence of social identification and academic learning*. New York: Cambridge University Press.
- Wortham, S. (2008). The objectification of identity across events. *Linguistics and Education, 19*, 294–311.
- Wortham, S. (2012). Introduction to the special issue: Beyond macro and micro in the linguistic anthropology of education. *Anthropology & Education Quarterly, 44*(2), 128–137.
- Wortham, S., & Rhodes, C. (2012). The production of relevant scales: Social identification of migrants during rapid demographic change in one American town. *Applied Linguistics Review, 3*(1), 75–99.
- Zhang, J., & Sun, Y. (2011). Reading for idea advancement in a grade 4 knowledge building community. *Instructional Science, 39*, 429–452.

---

# Critical Ethnography

Deborah Palmer and Blanca Caldas

---

## Abstract

Critical ethnography is a qualitative approach to research that explicitly sets out to critique hegemony, oppression, and asymmetrical power relations in order to foster social change. While all forms of critical ethnography work to interrogate the structures of power and lay bare inequities suffered by marginalized communities, some critical ethnographers work directly with community members, engaging in participatory research and ongoing dialogue with those being researched. Recently, critical ethnography has taken a turn toward exploring indigenous ways of knowing and producing knowledge, which has led the field in new and exciting directions.

This chapter will review scholarship that has worked to develop a coherent foundation for critical ethnographic research in terms of elaborating a range of approaches, dealing with issues of accountability and reliability, managing researcher ethics, and ensuring credibility of both the research process and findings. We explore in particular the challenges related to attempting to conduct critical ethnography within traditional research structures, such as Institutional Review Boards for research conducted with human subjects, and institutional expectations for publication.

Finally, in recent years, new contexts and needs have moved critical ethnographers to explore different compatible and contrasting epistemologies. Particu-

---

D. Palmer (✉)

School of Education, University of Colorado, Boulder, CO, USA

e-mail: [debpalmer@colorado.edu](mailto:debpalmer@colorado.edu)

B. Caldas (✉)

Second Language Education and Elementary Education, University of Minnesota, Twin Cities, Minneapolis, MN, USA

e-mail: [bcaldasc@umn.edu](mailto:bcaldasc@umn.edu)



larly, indigenous ways of knowing and creating knowledge have influenced an increasing number of researchers. This opening up of the field allows innovative and creative explorations to critique, denounce, and move to action.

### Keywords

Action research • Critical ethnography • Indigenous ways of knowing • Relational accountability

## Contents

Early Developments .....	382
Major Contributions .....	383
Work in Progress .....	385
Problems and Difficulties .....	387
Future Directions .....	389
Cross-References .....	390
Related Articles in the Encyclopedia of Language and Education .....	390
References .....	390

## Early Developments

Critical ethnography is an approach that draws on research and theory to critique hegemony, oppression, asymmetrical power relations, and the normalization of these structures in society, in order to potentially foster social change in direct or indirect ways. Critical ethnography shares methods with conventional ethnography, that is, long-term immersion in the field, participant observation, interviews, artifact collection, etc., to provide a “thick description” of the culture, daily lives, values, systems of beliefs, norms, and language practices of a specific culture or community (Geertz 1973). What sets critical ethnography apart is its focus on the way individuals within a marginalized community engage in *praxis* (Freire 1970) – a cycle of action and reflection – and on how members of the community exercise agency for cultural production and transformation. Madison (2011) and Kincheloe and McLaren (2000) describe critical ethnography as the doing or performance of critical theory whose aim is to deconstruct hegemony, and unveil oppression as an act of intellectual rebellion (Madison 2011) while imagining “what could be” (Thomas 1993). Kincheloe and McLaren (1994) argue that critical researchers should use their scholarship for social critique against covert or overt forms of privilege that reproduce and normalize social oppression, while at the same time understanding the intersectionality of race, class, and gender oppression in order to avoid oppression hierarchies. As Carspecken (1996) puts it, “criticalists find contemporary society to be unfair, unequal, and both subtly and overtly oppressive for many people. We do not like it, and want to change it” (p. 7). Therefore, critical ethnography is openly ideological (Lather 1986), which unavoidably colors each stage of the research process. From a critical ethnographic perspective, all research is ideologically tinged; critical ethnography is merely open about it, which allows an audience to better judge the credibility of the research.

In the field of educational research, critical ethnography started to gain prominence during the late 1970s and early 1980s (Anderson 1989). It has drawn influence from neo-Marxist critical theorists, critical feminist and Freirean research (Lather 1986), and the contributions of interpretative paradigms in anthropology and sociology (Anderson 1989). Critical ethnography was born of the need to move critical theory toward practice and move ethnography out of its alleged neutrality (Anderson 1989). Some critical ethnographers focus on the task of exposing hegemony and inequity so that others (such as policy makers, educators, or activists) might take action in order to change those conditions, while others engage in participatory action research for more direct outcomes within communities. A classic example of the former is Paul Willis' (1977) Marxist analysis of resistance, agency, and the reproduction of social class among male high school students from working class origins in Britain. Other examples of this kind of critical ethnography are present in the work of Anyon (1981) in the USA, Connell et al. (1982) in Australia, and McLaren (1986) in Canada.

An early example of critical ethnography with direct participation and benefits to the community is Sol Tax's (1963) "action" ethnography on the Mesquakie settlement in Iowa. Tax's study was a collaboration between the researcher (as a trusted insider) and the researched (members of the community) in order to solve community issues, such as community division, vandalism, lack of educational funds for college-ready Mesquakie people, and danger of losing autonomy over their schools. Foley and Valenzuela (2005) argue that this often forgotten work was groundbreaking since it dismantled the dichotomy between theoretical and applied knowledge. In the 1990s, Carspecken (1991) and May (1994) became blueprints of educational critical ethnographies in which researchers were involved with the community beyond observation. Moreover, May – and later Heller (1999) – bridged critical ethnography with sociolinguistic research examining minoritized language practices in both liberatory and oppressive spaces at schools in New Zealand and Canada, respectively. Whether involving direct action or offering thorough analysis, the impetus behind critical ethnography is to provoke others to move to change.

---

## Major Contributions

Scholars have tried to provide a coherent foundation for critical ethnographic research in terms of approach, accountability, researcher ethics, and credibility. Carspecken (1996) proposes a "five stage" approach for conducting critical ethnography to add some systematicity. Carspecken's first stage is "compiling a primary record" (p. 45) in which the researcher engages in writing a thick description of the research site and participants, preferably from the outsider perspective. The second stage is "preliminary reconstructive analysis" (p. 93), which consists of the creation of low- and high-level coding. Low-level codes are primarily descriptive and as objective as possible with a certain degree of abstraction; high-level coding builds on low-level codes for deeper analysis. During stage three, "dialogical data generation" (p. 154), member checking occurs. In the fourth stage, "describing system relations"

(p. 197), the themes that emerged throughout the previous stages are analyzed and described across sessions in order to corroborate, merge, and split themes and/or create subthemes. Finally, during the fifth stage, “system relations as explanations of findings” (p. 202), the ethnographer attempts to match the findings within the community studies with an existing social theory to explain environmental conditions, social reproduction, and cultural production and agency.

Madison (2011) conceptualizes critical ethnography as a three-part process highlighting the fact that often theory and method are intertwined in such a way that “my theory *was* my method, and my method was my theory” (p. 21). The starting point for Madison is introspection in order to identify the researcher’s connection with the issue to be explored while identifying other scholars engaged in similar quests, and identifying the participants to be “witnessed” (Madison 2010). The second stage of this process is to prepare a lay summary with the purpose of gaining access to the target population. Apart from including a research question, data collection and ethical methods, description of the population, and time frame, Madison (2011) maintains that a description of who the researcher is, the purposes behind the study, planned forms of representing data, selection processes, benefits and risks for participants, questions regarding confidentiality and anonymity, and considerations for data collection in tune with the participants’ culture are crucial in order to be accountable to the researched community. The third stage of the research process for Madison involves building rapport between researcher and participants.

Madison’s model relies heavily on the interview for the primary source of data collection. However, in critical ethnography, researcher and interviewee become more “conversational partners” (Madison 2011, p. 40). This kind of collaborative interview attenuates hierarchies and becomes dialogical due to the partnership fostered during the aforementioned second stage. Critical ethnography according to Madison is carried out when a researcher helps legitimize and make visible interviewees’ silenced realities, in juxtaposition with an official narrative, in the name of transformation and social justice. Central to this is the idea that knowledge is constructed and interpreted from the vantage point of the people whose voices are marginalized. Knowledge produced by silenced groups become theory in what Moraga and Anzaldúa (1981) call “theory in the flesh” (p. 23). Foley and Valenzuela’s (2005) description of the ethics underlying the production of critical ethnographies shares similar principles with regard to the interview: “a dialogic style of interviewing; intimate, highly personal informant relations; a community review of the manuscript; and writing in ordinary language” (p. 224). Ojha et al. (2009) use Madison’s approach in their work on the academic, political, and activist engagement of the authors in community-based strategies for forest conservation in Nepal among power differentials and inequalities. In the field of education, Silverman (2013) uses Madison’s tenets to examine music as a democratic form of expression and transformation in a music class in an urban high school in New York.

The most prominent feature that distinguishes Madison’s approach from Carspecken’s is the greater emphasis on the need for accountability and transparency. Madison and an increasing number of researchers (e.g., Chilisa 2012; Wilson 2008) insist that critical ethnographers need to embrace vulnerability through self-

reflexivity of their own positionality created in dialogue with participants. Madison points out that the unchecked/unmarked privileges, prejudices, and questions of power and positionality that accompany a researcher are issues that the critical ethnographer needs to (re)examine every step of the way while doing research and calls for self-exploration to uncover motivations, fears, and knowledge. According to Anderson (1989), this dialogical process involves the “(a) researcher’s constructs, (b) informants’ commonsense constructs, (c) research data, (d) researcher’s ideological biases, and (e) structural and historical forces that informed the social construction under study” (p. 254–255).

In the same vein, Conquergood (1985) describes the ethical and moral responsibility of the researcher toward the researched community. Using his own experience as an activist and advocate ethnographer among Hmong and Lao refugees in Chicago and the ethical tension he experienced as a white, middle-class man, Conquergood defines five research stances toward the researched: “the custodian’s rip-off,” “the skeptic’s cop-out,” “the enthusiast’s infatuation,” “the curator’s exhibitionism,” and “dialogical performance.” The “custodian’s rip-off” is the unethical stance that commodifies the knowledge obtained for self-gain, while the “skeptic’s cop-out” engages in detachment and othering. The “enthusiast’s infatuation” becomes unethical when trivializing the community’s practices, while the “curator’s exhibitionism” exoticizes and romanticizes the other. Finally, Conquergood’s “dialogical performance” embraces the cacophony or harmony of different voices – “heteroglossia” (Bakhtin 1998) – in order to get closer to the body, improvisation and entropy. This dialogical performance does not stop at understanding the personal and the interrelationships with others in the doing of culture, but goes on to engage in cultural politics, questioning power, and resistance.

Acknowledging that one of the perils of engaging in critique is the risk to a researcher’s credibility, Thomas (1993) describes eight traps that threaten critical ethnographers while conducting research. Thomas discourages concealing any data that may not fit a researcher’s political agenda, as well as using conceptual clichés/buzzwords, which could prevent the data from speaking for itself. He also warns researchers against overgeneralization and stridency with little or no evidence and encourages strengthening arguments having in mind audiences less familiar and potentially more critical of the research approach. Finally, Thomas urges critical researchers to embrace the changes that they will necessarily undergo when studying and becoming immersed in a community, and to open themselves up to the experience, both positive and negative, without romanticizing it. Taken together, these contributions frame the field of critical ethnography and provide guidelines to researchers carrying out this important and challenging work.

---

## Work in Progress

In recent decades, critical ethnographers have engaged in some creative interweaving of research approaches traditionally perceived as strictly separated and even conflicting (Lincoln and Guba 2005), a fertile ground for new modes of inquiry.

Performance ethnography and (performance) autoethnography are two variants of critical ethnography according to Madison (2011) in that they have political focus and are dialogical in nature. Performance ethnography engages subjects in the actual “doing of culture and democracy” (Jones 2006, p. 344). Such performances shape experience, meaning, culture, and its production. This methodology provides a different lens that is centered in the body as the source of knowledge addressing other bodies: concrete bodies that cannot be invisibilized and demand to be addressed. Madison (2010) extends the centrality of the body in performance ethnography even to the researcher, calling her/him a “co-performative witness” in that researchers live dialogically with participants within their spaces and struggles at certain points within their sociocultural context. Madison (2011) defines autoethnography as “the ethnography of one’s own social, ethnic, or cultural group” (p. 197), and she places it as another form of critical ethnography when it engages in critical self-reflexivity. Denzin (2009) goes further to place autoethnography at the intersection of the personal, political, historical, and cultural while critiquing cultural reproduction of everyday practices.

It is clear there is a strong need for performance in critical ethnography since in contrast with the traditional written presentation of research, performance begins to encompass the nuances and complexities of everyday cultural practices. Spry (2011) describes the process of creating a performance autoethnography as a parallel journey of self-creation and self-reflection while negotiating relationships with oneself and others. Spry reflects on the complexity of positionalities by embracing the coexistence of herself as participant observant, and herself as the “performative-I.” While Spry engages in performance autoethnography to problematize injustice connecting personal and national grief and healing post 9/11, Denzin (2003) uses performative autoethnography to critique and juxtapose historical and present representations of Native Americans drawing on dissonant multivocal (Bakhtin 1998) sources, such as memories, history textbooks, previous research, and popular culture. Madison (2010) turns her fieldwork notes, journal entries, and findings regarding a group of activists in contemporary Ghana into a multifaceted combination of theatrical plays, poetic narrative monologues, and creative nonfiction in which her multiple (and often contradictory) voices are intermeshed with the ones she “co-performative witnessed” (p. 25).

There are also important similarities between critical ethnography and action research/participatory action research (PAR) in that both include an emphasis on transformation, critical stance, and collaboration with the participants as coresearchers (Barab et al. 2004). Action research was inspired by Freire (1970) and Freire’s work in Tanzania in the early 1970s (Hall 2005). In this participatory strand of critical ethnography, the researcher becomes “researcher activist,” and as such, the researcher needs to focus on three crucial aspects: *trust* when developing relationships with the community, *intervention* as the researcher and the researched cocreate opportunities for social change, and the *sustainability* of such change (Barab et al. 2004).

The intersections among performance (auto)ethnography, (participatory) action research, and critical ethnography described above are present in the work of what

Murillo (2004) calls “mojado ethnographers,” as the *Other* becomes the researcher, further challenging issues of objectivity and neutrality and embracing vulnerability and ethical and political responsibility. Paris (2011), for example, shared the language practices and cultural performances of the Latino, Black, and Pacific Islander high school students he worked with, thus embracing his insider/outsider status. Similarly, Alim (2004) not only shared linguistic repertoire with his participants, but he also performed such cultural practice in his own writing. Mendoza-Denton (2008) relived the stereotypes she faced as a Latina in California as her work on female gang members and their linguistic and cultural practices were assumed to be autoethnographic. Malsbary (2014) highlighted her positionality as a transnational biracial woman to disclose her “hyphenated epistemologies” (p. 377) as a way to bring herself close to the immigrant ESL *lifers* she researched and their resistance to racio-linguistic policies in high school. As researchers continue to seek new ways to unveil hegemony, engage with marginalized communities, and work toward lasting change, new innovations that resemble, echo, and/or come out of critical ethnography are continually emerging.

---

## Problems and Difficulties

One issue faced by critical ethnographers is the question of validity. There is a certain skepticism regarding the rigor of the methods in critical ethnography to create generalizable and/or reliable knowledge that could potentially be translated into policy or practice. Lather (1986) argues that questions of validity for critical ethnography must be connected to its principles. Herr and Anderson (2005) outline five validity or quality criteria for action research, which can also apply to critical ethnography. These are dialogic, catalytic, process, democratic, and outcome validity. Dialogic validity comes in the form of peer review; that is, inquiry that is carried out collaboratively with other researchers has greater dialogic validity. Catalytic validity refers to the dynamic nature of research, which is in constant flux due to the transformation of understanding for both researcher and participants; research that reflects this transformation process is considered to have catalytic validity. Process validity is related to having a strong methodology that allows for triangulation of data and trustworthiness. Democratic validity ensures that the outcomes of the research will benefit the community researched. Finally, outcome validity refers to assessment of the achievement of community-based goals.

Another challenge critical ethnographers face is that of managing the inevitable conflicts between collaborative, engaged research projects and traditional conceptions of research produced as a researcher-only endeavor. For instance, in the USA, the process of approval and monitoring by the Institutional Review Board (IRB) has the potential to push researchers to deviate from the main goals of critical ethnography (i.e., collaboration for social change). When describing the IRB process for a critical ethnographer, Denzin (2003) argues that this one-size-fits-all process has potential to disregard non-Western ways of knowing and understanding. Confidentiality and consent seem far less applicable – or at least quite different – in

collaborative research; anonymity is often optional and sometimes undesirable (Denzin 2003). Moreover, due to the transformational orientation of critical ethnography, changes in the study are likely to occur with frequency, making it impractical to await IRB approval for amendments in research proposals and protocols, especially when changes have also been negotiated within the researched community. Likewise, central IRB concepts such as respect, beneficence, and justice take on new meanings in critical ethnographic work.

In general, it seems necessary to consider reframing the IRB process for critical ethnography and its new reformulations (Denzin 2003; Madison 2011). Critical ethnography as a mode of research is “more process oriented, collaborative, culturally located and contentious” (Madison 2011, p. 136). The American Association of University Professors reported the inadequacies of the IRB procedures, stating that “the unchecked power granted” (Thomson et al. 2006, p. 96) to the review board could become a threat to academic freedom. The lack of a comprehensive appeal process has potential to become a surveillance device with bias against participatory research projects that pose little risk and potentially much benefit to participants. Some projects may be rejected due to reviewers’ views on the importance of the knowledge gained, or reviewers’ definition of reasonable risk, or their own research preferences. The current IRB process discourages researchers from conducting critical, engaged research; it remains grounded in a bioscientific model that seems incompatible with the goals and processes of critical ethnography (Denzin 2003; Madison 2011).

Beyond the IRB process, actually the traditional perception of the process of knowledge production and dissemination in the academy – i.e., that knowledge is produced mainly by researchers and disseminated primarily through publication in academic journals – makes it difficult for advocate-activist researchers to engage in studies that fulfill the demands of academia, while trying to maintain a hands-on and political research agenda that goes beyond writing cultural critiques. Foley and Valenzuela (2005) point out that the pressures of scholarly production, tenure, and/or degree-granting processes have a tendency to prevent researchers from pursuing a more politically active role in the community, depriving them of the opportunity to be directly involved in grassroots organization and limiting them to work within academia.

Along these lines, because the question of accountability toward the researched community is crucial, critical ethnographers are constantly challenged to make their research accessible to the community, reducing the load of scientific/academic jargon commonly used to disseminate knowledge and seeking out ways to present and disseminate research to lay communities. Research appears to be traditionally intended almost exclusively for academic audiences, dissertation, and/or tenure committees and other researchers in the field and has been disseminated in the form of books, peer-reviewed articles, policy briefs, book chapters, or academic presentations. Yet it is possible to imagine a new ethnography where the researched community members are active participants in such dissemination as the authors and authorities of their own experiences, especially through non-textual means such as oral presentations or performances (Conquergood 1991).

## Future Directions

Critical ethnography has become a fertile ground for innovation within educational research. Researchers have taken up the tools of critical ethnography within a wide range of fields, including educational language policy and practice (McCarty et al. 2011), science and mathematics education (Tan et al. 2012), teaching and teacher education (Fitzpatrick 2013), and bilingual education and cultural studies (Cervantes-Soon 2014; Vaught 2011). At the same time, critical ethnography has been enhanced by research that has taken on different perspectives within critical theory, including post colonialism, critical race theory, Chicana feminism, queer theory, postcolonial feminism, and critical indigenous studies. One might argue that the merging of critical ethnography with all of these far-ranging frameworks has the potential to make the endeavor of critical ethnography disappear in its openness. On the contrary, this cross pollination enriches the field of critical ethnography since all approaches share the objective of democratizing our ways of conducting research.

The hybridization of research paradigms and methods that promote further cross-fertilization in critical ethnography has made possible its evolution using elements from a diversity of ways of knowing and alternative research approaches. Madison (2011) notes an affinity to critical ethnography within *indigenous* methodologies in particular. She elaborates on an indigenous ontological approach that links the four seasons of the year and the different research stages for self-awareness, coupled with the interdependence of research and nature to create balance. Adhering to this epistemology ensures that a researcher is prepared to conduct research within the context. The striking resemblance of indigenous approaches to critical ethnography is also evident in Smith's (2012) description of the purposes of indigenous research as an endeavor that "documents social injustice, that recovers subjugated knowledges, that helps create spaces for the voices of the silenced to be expressed and 'listened to,' and that challenge racism, colonialism and oppression. . ." (p.198). Indigenous approaches to research, as with other branches of critical ethnography, place the critical component not only on the lenses of the researcher who denounces social inequalities and/or intervenes for social change but also requires the researcher to be critical of Western research canons and to challenge colonizing ways of knowing. Some of the indigenous projects described by Smith (2012) are similar to forms that critical ethnography can take, such as storytelling through poetry (Denzin 2003, 2009), performance and scripts (Conquergood 1991; Spry 2011), testimonies or oral histories (Denzin 2003, 2009), and interventions (Ojha, et al. 2009; Silverman 2013).

Affinity to critical ethnography is not the sole condition for cross-fertilization with other methodological approaches. Unlike traditional ethnography, critical ethnography is not necessarily averse to embedding quantitative methodologies into the work in order to improve credibility. The inclusion of quantitative methodologies can potentially improve understanding of the complexities of the life experience of a given community. For instance, May (1994) included a pre- and post personally referenced evaluation for English language literacy performances to demonstrate external validity. Mertens (2007) provided examples of indigenous ethnography and



participatory action research – both of which are compatible with critical ethnography – to illustrate this collaboration. In those examples, quantitative data was collected – the former through standardized literacy assessments, and the latter through participant sampling that reflected the diversity within the community – in order to build trust among participants, and as a form of accountability for the outcomes of the research project. The mixed-methods approach exemplified by Mertens (2007) points to the possibility of this blending with the adoption of a cyclical model that includes the community as an active participant in research decisions and purposes.

Since its inception, critical ethnography has been evolving and expanding. As it takes in new perspectives and incorporates different approaches, it grows stronger. Both its fluidity and receptiveness to new voices and innovations are in tune with critical ethnography's original purposes of transformation, justice, and shared power. Critical ethnography continually works to bring marginalized communities to the center as agents of change, supporting them to be principal actors of their own experiences.

---

## Cross-References

- ▶ [Ethnography and Language Education](#)
- ▶ [Ethnography of Language Policy](#)
- ▶ [Linguistic Ethnography](#)

---

## Related Articles in the Encyclopedia of Language and Education

- Teresa McCarty and Serafin Coronel-Molina: [Language Education Planning and Policies by and for Indigenous Peoples](#). In: Volume: Language Policy and Political Issues in Education
- Tove Skutnabb-Kangas: [Linguistic Human Rights in Education](#). In Volume: Language Policy and Political Issues in Education

---

## References

- Alim, H. S., & American Dialect Society. (2004). *You know my steez: An ethnographic and sociolinguistic study of styleshifting in a Black American speech community*. Durham: Duke University Press for the American Dialect Society.
- Anderson, G. L. (1989). Critical ethnography in education: Origins, current status, and new directions. *Review of Educational Research*, 59(3), 249–270.
- Anyon, J. (1981). Social class and school knowledge. *Curriculum Inquiry*, 11(1), 3–42.
- Bakhtin, M. K. (1998). *The dialogic imagination*. Austin: University of Texas Press.
- Barab, S. A., Thomas, M. K., Dodge, T., Squire, K., & Newell, M. (2004). Critical design ethnography: Designing for change. *Anthropology & Education Quarterly*, 35(2), 254–268.

- Carspecken, P. F. (1991). *Community schooling and the nature of power: An analysis of the battle for Croxteth Comprehensive*. London: Routledge.
- Carspecken, P. F. (1996). *Critical ethnography in educational research: A theoretical and practical guide*. New York: Routledge.
- Cervantes-Soon, C. G. (2014). The US-Mexico border-crossing Chicana researcher: Theory in the flesh and the politics of identity in critical ethnography. *The Journal of Latino-Latin American Studies*, 6(2), 97–112.
- Chilisa, B. (2012). *Indigenous research methodologies*. Thousand Oaks: Sage.
- Connell, R., Ashenden, D., Kessler, S., & Dowsett, G. (1982). *Making the difference: Schools, families and social division*. London: Allen & Unwin.
- Conquergood, D. (1985). Performing as a moral act: Ethical dimensions of the ethnography of performance. *Literature and Performance*, 5(2), 1–13.
- Conquergood, D. (1991). Rethinking ethnography: Towards a critical cultural politics. *Communication Monographs*, 59, 179–194.
- Denzin, N. K. (2003). *Performance ethnography: Critical pedagogy and the politics of culture*. Thousand Oaks: Sage.
- Denzin, N. K. (2009). A critical performance pedagogy that matters. *Ethnography and Education*, 4(3), 255–270.
- Fitzpatrick, K. (2013). *Critical pedagogy, physical education and urban schooling*. New York: Peter Lang.
- Foley, D., & Valenzuela, A. (2005). Critical ethnography: The politics of collaboration. In N. K. Denzin & Y. S. Lincoln (Eds.), *Handbook of qualitative research* (pp. 217–234). Thousand Oaks: Sage.
- Freire, P. (1970). *Pedagogy of the oppressed*. New York: Herder & Herder.
- Geertz, C. (1973). *The interpretation of cultures*. New York: Basic Books.
- Hall, B. L. (2005). In from the cold? Reflections on participatory research from 1970–2005. *Convergence*, 38(1), 5–24.
- Heller, M. (1999). *Linguistic minorities and modernity: A sociolinguistic ethnography*. London: Longman.
- Herr, K., & Anderson, G. L. (2005). *The action research dissertation: A guide for students and faculty*. Thousand Oaks: Sage.
- Jones, J. L. (2006). Performance and ethnography, performing ethnography, performance ethnography. In D. S. Madison & J. Hamera (Eds.), *The Sage handbook of performance studies* (pp. 339–346). Thousand Oaks: Sage.
- Kincheloe, N., & McLaren, P. (1994). *You can't get to the yellow brick road from here*. New York: Routledge.
- Kincheloe, N., & McLaren, P. (2000). Rethinking critical theory and qualitative research. In N. Denzin & Y. S. Lincoln (Eds.), *Handbook of qualitative research* (2nd ed., pp. 303–342). Thousand Oaks: Sage.
- Lather, P. (1986). Issues of validity in openly ideological research: Between a rock and a soft place. *Interchange*, 17, 63–84.
- Lincoln, Y. S., & Guba, E. (2005). Paradigmatic controversies, contradictions, and emerging confluence. In N. K. Denzin & Y. S. Lincoln (Eds.), *The Sage handbook of qualitative research* (2nd ed., pp. 163–188). Thousand Oaks: Sage.
- Madison, D. S. (2010). *Acts of activism: Human rights as radical performance*. Cambridge: Cambridge University Press.
- Madison, D. S. (2011). *Critical ethnography: Method, ethics, and performance*. Thousand Oaks: Sage.
- Malsbary, C. (2014). “Will this hell never end?”: Substantiating and resisting race-language policies in a multilingual high school. *Anthropology & Education Quarterly*, 45(4), 373–390.
- May, S. (1994). *Making multicultural education work*. Clevedon: Multilingual Matters.

- McCarty, T., Romero-Little, M. E., Warhol, L., & Zepeda, O. (2011). Critical ethnography and indigenous language survival: Some new directions in language policy research and praxis. In T. McCarty (Ed.), *Ethnography and language policy* (pp. 31–51). New York: Routledge.
- McLaren, P. (1986). *Schooling as a ritual performance: Towards a political economy of educational symbols and gestures*. London: Routledge & Kegan Paul.
- Mendoza-Denton, N. (2008). *Homegirls: Language and cultural practice among Latina youth gangs*. Malden: Blackwell.
- Mertens, (2007). Transformative paradigm: Mixed methods and social justice. *Journal of Mixed Methods Research*, 1(3), 212–225.
- Moraga, C., & Anzaldúa, G. (1981). *This bridge called my back: Writings by radical women of color*. Watertown: Persephone Press.
- Murillo, E. (2004). Mojado Ethnography: Making meaning of the alliances-reversals-paradoxes-positionalities along the neoliberal borderlands (Reprint). In G. W. Noblit, E. G. Murillo Jr., & S. Y. Flores (Eds.), *Postcritical ethnography in education* (pp. 157–166). Cresskill: Hampton Press.
- Ojha, H. R., Cameron, J., & Kumar, C. (2009). Deliberation or symbolic violence? The governance of community forestry in Nepal. *Forest Policy and Economics*, 11, 365–374.
- Paris, D. (2011). *Language across difference: Ethnicity, communication, and youth identities in changing urban schools*. Cambridge, UK: Cambridge University Press.
- Silverman, M. (2013). A critical ethnography of democratic music listening. *British Journal of Music Education*, 30(1), 7–25.
- Smith, L. T. (2012). *Decolonizing methodologies: Research and indigenous peoples*. London: Zed.
- Spry, T. (2011). *Body, paper, stage: Writing and performing autoethnography*. Walnut Creek: Left Coast Press.
- Tan, E., Calabrese, B. A., Varley, G. M., & Turner, E. (2012). *Empowering science and mathematics education in urban schools*. Chicago: University of Chicago Press.
- Tax, S. (1963). *Penny capitalism: A Guatemalan Indian history*. Chicago: University of Chicago Press.
- Thomas, J. (1993). *Doing critical ethnography*. Newbury Park: Sage.
- Thomson, J., Elgin, C., Hyman, D., Rubin, P., & Knight, J. (2006). Research on human subjects: Academic freedom and the Institutional Review Board. *Academe*, 92(5), 95–100.
- Vaught, S. E. (2011). *Racism, public schooling, and the entrenchment of white supremacy: A critical race ethnography*. Albany: State University of New York Press.
- Willis, P. (1977). *Learning to labor*. New York: Columbia University Press.
- Wilson, S. (2008). *Research is ceremony: Indigenous research methods*. Black Point: Fernwood Pub.

---

# Visual Methods in Researching Language Practices and Language Learning: Looking at, Seeing, and Designing Language

Anne Pitkänen-Huhta and Sari Pietikäinen

---

## Abstract

The changing ways of using language and various understandings of what *language* is have consequences for the way we research language practices and language learning. When engaging in social contact, people use diverse and complex forms, modes, and varieties of language to communicate, and moreover, these resources often include icons, images, and other semiotic ways of meaning making. Visuality thus has a natural position in people's language practices. In this chapter, we discuss how visual methods have been adopted and used as a methodological tool in researching language practices and language learning. With this focus, attention is geared to the materiality of language, on the one hand, and to the alternative and complementary strategies to study experiences and meaning making of language users and learners, on the other. In presenting the major contributions and work in progress from this perspective, we focus on discourse ethnographic approaches in the contexts of language learning, multilingualism, and identity negotiations, and we have structured our text around the visual research strategies of *looking, seeing, and designing*.

---

## Keywords

Visual methods • Language • Language learning • Language practices • Multilingualism

---

A. Pitkänen-Huhta (✉)

Department of Languages, University of Jyväskylä, Jyväskylä, Finland  
e-mail: [anne.pitkanen-huhta@jyu.fi](mailto:anne.pitkanen-huhta@jyu.fi)

S. Pietikäinen

Department of Languages and Discourse Studies, University of Jyväskylä, Jyväskylä, Finland  
e-mail: [sari.pietikainen@jyu.fi](mailto:sari.pietikainen@jyu.fi)

## Contents

Introduction .....	394
Developments of Visual Methods .....	395
Significant Current Trends .....	397
Looking at Language .....	397
Seeing Language .....	399
Designing Language .....	401
Future Directions .....	403
Cross-References .....	403
Related Articles in the Encyclopedia of Language and Education .....	404
References .....	404

## Introduction

The changing ways of using language and various understandings of what *language* is have consequences for the way we research language practices and language learning. When engaging in social contact, people use diverse and complex forms, modes, and varieties of language to communicate, and moreover, these resources often include icons, images, and other semiotic ways of meaning making. Visuality thus has a natural position in people's language practices. Visual methods have a long tradition in social sciences (for reviews see, e.g., Holm 2008; Prosser and Loxley 2008; Prosser 2011), but in the field of language research, they are a fairly recent phenomenon. Language researchers have developed visual methods especially toward ethnographic and participatory research strategies and consequently engaged informants as active agents who narrate their personal experiences through visual means. There is now a growing body of research using visual and multimodal research methods to examine practices, discourses, and experiences of and around language.

In this chapter, we discuss how visual methods have been adopted and used as a methodological tool in researching language practices and language learning.<sup>1</sup> With this focus, attention is geared to the materiality of language, on the one hand, and to the alternative and complementary strategies to study experiences and meaning making of language users and learners, on the other. In presenting the major contributions and work in progress from this perspective, we focus on discourse ethnographic approaches in the contexts of language learning, multilingualism, and identity negotiations, and we have structured our text around the visual research strategies of *looking*, *seeing*,<sup>2</sup> and *designing*. First, we will, however, outline early developments in the field.

<sup>1</sup>We limit the scope of this chapter strictly to language research methodology and thus exclude here the wide array of research in the area of computer-assisted language learning (CALL) and computer-mediated communication (CMC) as well as various kinds of pedagogical developments where visual methods and the media have been widely used.

<sup>2</sup>Berger (1972) used a similar metaphor in his book *Ways of Seeing*, and Prosser (2011) also used the word *seeing* in his article, "Visual methodology: Toward a more seeing research."

## Developments of Visual Methods

Early anthropological research, starting from Boas and Malinowski, paved way for the use of images in studying communities and practices. Early research mainly made use of photographs taken by the researchers themselves to document the habits and customs of communities by photographing people, artifacts, events, and so on. The images were used to represent reality, but as Prosser and Loxley (2008, p. 6) say, those who criticized the use of photographs argued that photographs were merely used either as illustrations or as support for ideological statements. Even though images are widely used today, they can still be regarded as too subjective to be considered rigorous research (Holm 2008).

In language research too, visual methods have been used in several areas. One of the very early areas where images have had a prominent position is semiotics. Pioneers in developing the analysis of images and in creating a grammar of visual images are Kress and van Leeuwen (1996). Scollon and Scollon (2004) have developed the study of our semiotic environment in terms of discourse, agency, and practice (i.e., nexus analysis) emphasizing the materiality of the environment and calling this approach *geosemiotics*. This paved way for research on another area of language studies, namely, the study of linguistic landscapes (e.g., Backhaus 2006; Shohamy and Gorter 2009). In examining linguistic landscape, visual methods, mainly photographing, are used to document the signs and their placement.

Another area in language studies where visual methods have been applied is ethnographic research on language practices and language learning. Visual methods have been used, for example, in studying literacy practices, language identities, and multilingualism. The earliest studies where photographs were particularly used can be found in the research area of New Literacy Studies by the Lancaster group (Barton and Hamilton 1998; Hamilton 2000; Hodge and Jones 2000). These studies were interested in exploring and interpreting people's everyday literacy practices. Their primary methodological framework was ethnography, within which they reintroduced the use of photographs to document the textual environments people live in and the literacy practices they engage in. More recent ethnographic research where visual methods have had a prominent role includes research on multilingual practices of young children in an indigenous language context (Pietikäinen 2012; Pietikäinen and Pitkänen-Huhta 2013), young people's language practices (Nikula and Pitkänen-Huhta 2008), multilingual language repertoires (Busch 2010), and language portraits (Farmer and Prasad 2014).

In studying language identities, visual methods, including photos, but also material objects such as cultural or family artifacts have been used to evoke people's memories and relations to language in their life histories (e.g., Galasinski and Galasinska 2005; Karjalainen 2012). Photographs have been prominent in these studies, but also drawings have been used in researching the complexities of multilingualism and language learning. With children in particular, drawing has proven to be a plausible way of accessing complex and abstract issues to complement the more traditional methods of data collection, such as interviewing. In a

pioneering work by Krumm (2001), a method called language portraits was developed to explore individual's language biographies in changing environments including migration, mobility, and multilingualism. This method, utilizing embodied visualization of language repertoires, has been further developed by scholars such as Busch in her studies on language repertoires at school (Busch 2010) as well as in research on language and mobility (Farmer and Prasad 2014) and endangered languages as a part of developing multilingual repertoires (Pietikäinen and Pitkänen-Huhta 2014). Drawings have also been applied in the context of language learning. For example, Pietikäinen et al. (2008) used drawings to study children's multilingualism, Nikula and Pitkänen-Huhta (2008) investigated young Finn's relationship to English in their everyday practices through visualizations, and Iddings et al. (2005) as well as Kalaja et al. (2013) asked EFL learners to draw self-portraits to trace the development of learner identities.

Another way of looking at visual methods in studying language practices and language learning is to examine how the visual material is employed as research data. The uses can be divided into four different approaches. All of these could be called participatory, as in all of them the participants of the research are in a central role and are engaged in the research process in a special way with the aim of empowerment, for example. The first of these is to use photographs (or other visual material or cultural artifacts) to elicitate other kinds of data (e.g., verbal protocols, narratives) from research participants (e.g., Galasiński and Galasińska 2005; Karjalainen 2012). The second way is to ask the participants to take photographs of the object of research and thus to produce data (Farmer 2012; Hodge and Jones 2000; Nikula and Pitkänen-Huhta 2008; Pietikäinen 2012). The third one is similar to the second one in that the participants create data, but instead of taking photographs they create drawings or other visual images (Farmer 2012; Iddings et al. 2005; Kalaja et al. 2013; Pietikäinen 2008; Pietikäinen et al. 2008). Finally, the visual material may be used to document the research site and facilitate access to the field (Barton and Hamilton 1998; Hodge and Jones 2000). Visual material may become data as the research project develops. For example, Pietikäinen and Pitkänen-Huhta (2013, 2014) and Pitkänen-Huhta and Pietikäinen (2014) studied evolving multilingual practices in an indigenous language medium classroom. As a set of various other activities utilizing visual methods (e.g., Pietikäinen 2012), the children also created multimodal picture books, which is an approach employed in various multilingual contexts (e.g., Busch 2010; Farmer 2012). In this study, the creation of the books had multiple functions. It was a school task for the children, it was part of ethnographic study of the researchers, and it was a community effort in the process of language revitalization.

In the following, we will present current major discourse ethnographic work in the area of language research through three different ways of conceptualizing the research strategies adopted in the studies.

## Significant Current Trends

Our focus here is on discourse ethnographic approaches in the contexts of language learning, multilingualism, and identity negotiations. This reflects both our own position and experiences as well a more general tendency in applying visual methods in research on language practices and language learning. In the following, we have structured our text around visual and mental processes of *looking*, *seeing*, and *designing*. We chose these metaphors to capture some aspects of the various visual research strategies used in language research and to discuss typical ways of working with research participants, data, analysis, and findings as well as their pros and cons. While these three processes are overlapping and intertwined, for the purposes of this article, they are apt in bringing forth different, even though interrelated and complementary, aspects of visualizing language: the relationship between language and language user/learner, between the data under scrutiny and the analysis of that data, and between the researcher and the researched. In addition, by using expressions reflecting an on-going process rather than a state depicted by nominals, we aim to highlight two important starting points in using visual research strategies in language research: language – be it understood as textual, visual, verbal, material, or embodied – is seen as social action, and language user as a social agent (Fairclough 1992; Scollon and Scollon 2004). In addition, using visual methods in language research raises questions of knowledge production and positions of “knowing,” as they foreground questions of co-construction of knowledge and collaborative researching and break the traditional categories and understandings of data, data collection, and data analysis. The three processes also capture the expansion of the role of participation in researching language visually: they form a continuum from researching somebody (*looking at language*) to researching with somebody (*seeing language*) to researching by doing something with somebody (*designing language*). In connection with each of these three processes, we will also address some challenges that researchers face in using visual methods.

## Looking at Language

See Fig. 1.

*The young people participating in this discourse ethnographic project were asked to take photographs of places, objects or activities where English played some kind of role. Taking photographs seemed to be a very natural activity for the young and they also produced very similar sets of photographs. Music played an important role for all of them: they listened to English music constantly and both the music and the lyrics were important to them. They felt pride that they could understand the lyrics and through music they felt to be part of the international imagined community of young people.*



**Fig. 1** Photograph of music CDs



This photo illustrates the visual research strategy of *looking at language* employed to study young Finns' uses of English in their everyday activities. The aim of the participant-taken photographs was to gain a window into the everyday lives of the young. Looking as a process of examining language practices turns our attention to the material object, in this case the picture, that captures our gaze. Looking at this visualization of English music provides a reflection point, both for the photographer him/herself as well as us viewers, to examine experiences related to English: what role does the language play in my everyday activities, where does it connect to, and how do I relate to it? The process of looking is further mediated by the use of camera: the lens of the camera chooses and frames one particular moment in time and transforms it as an object, to be placed alongside textual information for others to view in a new context (such as this chapter). As such the photo can be understood as a complex, culturally situated nexus of circulating discourses of languages in our lives, learning to cope with foreign languages, youth cultures, internationalization and globalization of popular culture, as well as personal experiences and emotions of the photographers (cf. Scollon and Scollon 2004). These components of the photograph can be traced with the help of other methods, such as by interviewing the photographer and by mapping out circulating discourses across other photos or other data (cf. Cappello 2005; Pietikäinen 2012). The interpretation of the significance and meaning of the photo is co-constructed in dialogue with the producer and the viewer and in dialogues with other research participants and other sources of data, as well as with the conceptual frameworks in use. Thus the photograph evokes complex relationships between the people involved as well as between personal experiences and social practices and discourses.

The value of photography in language research lies in its potential to make visible the experiences and practices related to language and to bypass some constraints related to, for example, language skills and boundaries between languages. It has the potential to provide new understandings and make visible the processes of learning

and teaching, co-constructions of knowledge and language ideologies, as well as engage in critical reflections and discussions. The challenges may be related to more practical sides of photographing: equipment, costs, copyright, and ethics. Another type of a challenge is linked to the multiple ways of looking at and interpreting the image and thereby language. The photograph itself tells one story and it can be interpreted differently by the producer and the viewer (researcher). This may be problematic from the point of view of data analysis, but it also points to the complexity of issues related to language practices and to the concepts around language practices and language learning. The problem may be overcome through dialogue with other type of data, such as interviews.

In addition to exploring how language practices and learning look alike, as illustrated above, another way of utilizing visual methods in language research attempts to tap in how people make sense of their changing language environments. In this context, visual methods can be one way of examining how language can be seen – both literally and metaphorically – and we turn to look at this next.

## Seeing Language

See Fig. 2.

*This drawing was created in the context of university studies. First year students majoring or minoring in English (as a foreign language) were asked to draw themselves as learners of EFL. This was done as coursework and a permission was asked to use the drawings as research data. The students were provided with an*

**Fig. 2** Learner portrait



*A4 sized framed sheet of paper with the title SELF-PORTRAIT and with an added caption saying. This is what look like as an EFL learner (Kalaja et al. 2013).<sup>3</sup>*

The drawing exemplifies the visual research strategy of *seeing language*. In this context, seeing has a double meaning: first, it refers to the perception of something with your eyes. This underlines the physical aspects of this process: it is something that we do with one of our senses, namely, the sight. Secondly, it also refers to becoming aware of something as a result of observing something by using your eye. In this sense seeing refers to the processes of reflection, understanding, and interpretation (cf. I see what you mean). This brings in the cognitive aspect of seeing. Together seeing is then both a physical (perception) and cognitive (awareness, understanding) process. The research strategy of *seeing language* can thus be used to connect the physical world or material artifact and the process of understanding.

The research strategy of *seeing language* has been applied in various ways, but within the field of language research typically with working around drawings. One type of application can be called user- or learner-centered drawings, where the drawings are used to get insight into the beliefs, motivations, and experiences related to language, language learning, and multilingualism as experienced and visualized by the language user. For example, Kalaja et al. (2013) used language portraits as a way to tap in the beliefs around foreign language learning. Similar work has been done by Busch (2010), Farmer (2012), Pietikäinen et al. (2008), and Pietikäinen and Pitkänen-Huhta (2014) to examine multilingual practices in indigenous language revitalization contexts.

Another type of application of the drawings can be named spatiotemporal visualizations. The drawings are used to map the trajectories of usage of particular languages in terms of time and context, including activities and interlocutors. One example of this is a visual language diary, in the form of a clock. In the instructions, the informants are asked to mark down in the clock when and with whom they have used different languages (Satchwell 2005). Another example is the map of language environment: the informant is asked to map various activities she/he is engaged with, for example, during one day or in a particular role (as a parent, as a teacher, etc.) and to mark down the languages she/he uses in these contexts (cf. Pietikäinen 2008). These kinds of visualizations help to understand the affordances and constraints relating to particular languages.

Drawings as a method for seeing language are flexible and practical in the sense that they do not require access to specific technology or related skills, only the traditional means of pen and paper are sufficient. A challenge may, however, be that the participants may feel intimidated by the task if they feel they do not have the necessary artistic skills of drawing. School experiences of being “a good or bad drawer” may be evoked when facing a task like this later in life. Therefore it is very important that the researchers emphasize that artistic skills pay no role and that any kinds of visual means can be used.

---

<sup>3</sup>We wish to thank Paula Kalaja, Riikka Alanen, and Hannele Dufva for giving us permission to use their data as an example of *seeing language*.

As with photographs, the challenges with drawings are related to the interpretation and analysis of them as data. Research has approached analysis in various ways depending on the theoretical framework and the conceptualizations of language. Drawings have been considered visual discourses (Pietikäinen 2012) and analyzed as a nexus of complex web of discourses surrounding the image. Another way of approaching analysis is to see images as visual narratives (Besser and Chik 2014; Kalaja et al 2013; Nikula and Pitkänen-Huhta 2008) have also been as multimedia narratives (Menezes 2008; Nelson 2006). Drawings have also been analyzed semiotically as an image analysis or viewed as part of multimodal literacy practices (Pietikäinen and Pitkänen-Huhta 2013).

We have so far moved from looking at language practices and language learning to understanding and interpreting practices and learning. Next we will turn to the research strategy of designing language and collaborative research.

## Designing Language

See Fig. 3.

**Fig. 3** Multilingual picture books



*As a part of a larger, critical discourse ethnographic research on multilingualism in indigenous Sámi communities, a set of participatory activities were designed and carried out together with the teachers and the pupils taking part in Sámi medium education. One of these was a literacy event in which multilingual Sámi primary-school children worked on a school task of designing their own multimodal, multilingual picture books.<sup>4</sup> The books were printed and circulated across other Sámi medium classrooms as supplementary reading material. The authors enjoyed the project, finding new connections and functions of multilingual and multimodal resources (Pitkänen-Huhta and Pietikäinen 2014).*

As a research strategy, *designing language* refers not only to the planning but also making decisions and acting accordingly to accomplish a goal, which usually takes a material form. Importantly for language research, this strategy foregrounds the agency of the participants and the collaborative activities among all participants, the researcher included. The participants become active agents who work on the resources available to them, be they material, linguistic, or visual, to produce a material artifact. This strategy extends and moves beyond the visual practices in that it connects the visual material to the wider practices of production and circulation of material artifacts.

This multisided process of designing and producing the material artifact, such as the book above, can be used as a powerful methodological tool in language research. Designing a material artifact is embedded in the particular conditions of production, and one aspect of it is related to language ideologies. For example, the production of the little book above in the multilingual indigenous language environment involved complex and multilayered negotiations of which languages to include, how to handle the issues of standard writing, and the hierarchies and values attached to particular languages. Another aspect of using the research strategy of designing language is that it foregrounds the methods of collaborative research. The traditional roles and positions of the researcher and researched are blurred as the informants become a more integral part of the research process and the research team. The process turns into researching by doing and doing in collaboration – not only between the researchers and informants but also by extending the collaboration to the community and other stakeholders.

In this sense, this kind of collaborative project captures two shifts in language research at the same time: the material turn and researching by doing. Within language research, one major terrain where language designing has been used is in the production of teaching/learning or multilingual materials, especially in a context where they are scarce (cf. Busch 2010; Pietikäinen and Pitkänen-Huhta 2014). The collaborative project may also involve the production of other material products besides books. For example, Farmer (2012) used the making of a quilt as a tool for making connections between social mobility and physical mobility in the context of the changing

---

<sup>4</sup>We wish to thank Brigitta Busch for her generous help in this subproject and Leena Huss for collaboration in designing the data collection in Sámiland. Our warmest thanks go to the pupils, teachers, and parents.

multilingual classroom. We can also see glimpses of these kinds of collaborative projects involving language issues and designing a product in various campaigns involving such as designing t-shirts or mittens (<http://www.discoursehub.fi/>).

The research strategy of designing language serves multiple functions. First of all, it helps in valorizing language resources that might otherwise remain hidden. In the tasks described above, the participants were given fairly free hands to create the material artifact. As opposed to a purely teacher- or researcher-imposed task, this freedom encouraged the participants to explore and see the various language resources in their environment. Secondly, designing facilitates the use of various linguistic and other semiotic resources to create artifacts that are personally meaningful and which thus empower the participants in their use and appropriation of all available resources. Thirdly, these kinds of tasks increase the users' multilingual awareness, and finally, they help in the production of teaching materials that are bottom-up and thus typically user friendly.

---

## Future Directions

We have here outlined research that has made use of photographs, drawings, and material artifacts and discussed the ways in which they can be used to learn more about language practices and learning. What we have ignored here, but anticipate that will become more salient in language research, too, is the wealth of visual means making use of moving images and shared social media. YouTube clips of language-related comedies, rap performances, and makeovers of popular hits or Facebook accounts created for collaborative learning (teach-your-self X languages), gaming, and social networking are examples of the ways in which a new kind of multimodal communication is used in creative ways to promote language learning, multilingual awareness, and a sense of language community and identity (cf. Blake 2013; Pietikäinen and Dufva 2014). The emerging ways of using language and photo in a context of social media continue to blur the boundaries between visual/textual, producer/user, and private/public and create new genres and practices for language use, learning, and identity work (Marwick and Boyd 2011; Senft 2013). The rapidly changing world of visual culture – with innovative ways of using languages, visualities, and technologies – offers novel and crucial sites for examining language and emerging language practices. Researchers should follow the developments closely and actively engage in creating new ways of employing visual methods.

---

## Cross-References

- ▶ [Arts-Based Approaches to Inquiry in Language Education](#)
- ▶ [Researching Computer-Mediated Communication](#)
- ▶ [Researching Language Loss and Revitalization](#)
- ▶ [Researching Multimodality in Language and Education](#)

## Related Articles in the Encyclopedia of Language and Education

Carey Jewitt: [Multimodal Discourses Across the Curriculum](#). In Volume: Language, and Technology

---

## References

- Backhaus, P. (2006). Multilingualism in Tokyo: A look into the linguistic landscape. *International Journal of Multilingualism*, 3(1), 52–66.
- Barton, D., & Hamilton, M. (1998). *Local literacies. Reading and writing in one community*. London: Routledge.
- Berger, J. (1972). *Ways of seeing*. London: BBC & Penguin.
- Besser, S., & Chik, A. (2014). Narratives of second language identity amongst young English learners. *ELT Journal*, 68(3), 299–309.
- Blake, R. (2013). *Brave new digital classroom: Technology and foreign language learning* (2nd ed.). Washington, DC: Georgetown University Press.
- Busch, B. (2010). School language profiles: Valorizing linguistic resources in heteroglossic situations in south Africa. *Language and Education*, 24(4), 283–294.
- Cappello, M. (2005). Photo interviews: Eliciting data through conversations with children. *Field Methods*, 17(2), 170–182.
- Fairclough, N. (1992). *Discourse and social change*. Cambridge: Polity Press.
- Farmer, D. (2012). Portraits of jeunes migrants dans une école internationale au Canada. *La revue internationale de l'éducation familiale*, 31, 73–94.
- Farmer, D., & Prasad, G. (2014). Mise en récit de la mobilité chez les élèves plurilingues: Portraits de langues et photos qui Engagent les jeunes dans une démarche réflexive. *Glottopol: Revue de sociolinguistique en ligne*, 24. <http://glottopol.univ-rouen.fr>. Accessed 10 Nov 2014.
- Galasiński, D., & Galasińska, A. (2005). Untold stories and the construction of identity in narratives of ethnic conflict on the Polish-German border. *Multilingua*, 24(1–2), 101–120.
- Hamilton, M. (2000). Expanding the new literacy studies: Using photographs to explore literacy as social practice. In D. Barton, M. Hamilton, & R. Ivanič (Eds.), *Situated literacies: Reading and writing in context* (pp. 16–34). London: Routledge.
- Hodge, R., & Jones, K. (2000). Photography in collaborative research on multilingual literacy practices: Images and understandings of researcher and researched. In M. Martin-Jones & K. Jones (Eds.), *Multilingual literacies* (pp. 299–318). Amsterdam: John Benjamins.
- Holm, G. (2008). Visual research methods: Where are we and where are we going? In S. N. Hesse-Biber & P. Leavy (Eds.), *Handbook of emergent methods* (pp. 325–341). New York: Guilford Press.
- Iddings, A. C. D., Haight, J., & Devlin, R. (2005). Multi-modal representations of self and meaning in English-dominant classrooms. In J. Kelly-Hall, G. Vitanova, & L. Marchenkova (Eds.), *Dialogue with Bakhtin on second language learning: New perspectives* (pp. 33–53). Mahwah: Lawrence Erlbaum.
- Kalaja, P., Dufva, H., & Alanen, R. (2013). Experimenting with visual narratives. In G. Barkhuizen (Ed.), *Narratives in applied linguistics* (pp. 105–131). Cambridge: Cambridge University Press.
- Karjalainen, A. (2012). *Liikkuva ja muuttuva suomi: diskursiivis-etnografinen tutkimus amerikkansuomalaisten kielielämäkertoista* [The Finnish language in motion. An ethnographic and discourse analytic study of Finnish-American language biographies] (unpublished doctoral dissertation). Jyväskylä: University of Jyväskylä.
- Kress, G., & Van Leeuwen, T. (1996). *Reading images: The grammar of visual design*. New York: Routledge.
- Krumm, H. J. (Ed.). (2001). *Kinder und ihre Sprachen – lebendige Mehrsprachigkeit*. Vienna: Eviva.

- Marwick, A., & Boyd, D. (2011). I tweet honestly, I tweet passionately: Twitter users, context collapse, and the imagined audience. *New Media and Society*, 13(1), 114–133.
- Menezes, V. (2008). Multimedia language learning histories. In P. Kalaja, V. Menezes, & A. M. Ferreira Barcelos (Eds.), *Narratives of learning and teaching EFL* (pp. 199–213). Basingstoke: Palgrave.
- Nelson, M. (2006). Mode, meaning, and synaesthesia in multimedia L2 writing. *Language Learning & Technology*, 10(2), 56–76.
- Nikula, T., & Pitkänen-Huhta, A. (2008). Stories of learning English as revealed by photographs and discussions. In P. Kalaja, V. Menezes, & A. M. Ferreira Barcelos (Eds.), *Narratives of learning and teaching EFL* (pp. 171–185). Basingstoke: Palgrave.
- Pietikäinen, S. (2008). Sami in the media: Questions of language vitality and cultural hybridisation. *Journal of Multicultural Discourses*, 3(1), 22–35.
- Pietikäinen, S. (2012). Experiences and expressions of multilingualism: Visual ethnography and discourse analysis in research with Sámi children. In S. Gardner & M. Martin-Jones (Eds.), *Multilingualism, discourse and ethnography* (pp. 163–178). New York: Routledge.
- Pietikäinen, S., & Dufva, H. (2014). Heteroglossia in action: Sámi children, textbooks and rap. In A. Blackledge & A. Creese (Eds.), *Heteroglossia as practice and pedagogy* (pp. 59–74). Dordrecht: Springer.
- Pietikäinen, S., & Pitkänen-Huhta, A. (2013). Multimodal literacy practices in the indigenous Sámi classroom: Children navigating in a complex multilingual setting. *International Journal of Language, Identity and Education*, 12(4), 230–247.
- Pietikäinen, S., & Pitkänen-Huhta, A. (2014). Dynamic multimodal language practices in multilingual indigenous Sámi classrooms in Finland. In D. Gorter, V. Zenotz, & J. Cenoz (Eds.), *Minority languages and multilingual education. Bridging the local and the global* (pp. 137–157). Heidelberg: Springer.
- Pietikäinen, S., Dufva, H., Alanen, R., Kalaja, P., Leppänen, S., & Pitkänen-Huhta, A. (2008). Languageing in Ultima Thule: Multilingualism in the life of a Sami boy. *International Journal of Multilingualism*, 5(2), 79–99.
- Pitkänen-Huhta, A., & Pietikäinen, S. (2014). From a school task to community effort: Children as authors of multilingual picture books in an endangered language context. In C. Hélot, R. Sneddon, & N. Daly (Eds.), *Children's literature in the multilingual classroom* (pp. 138–153). London: Institute of Education Press & Trentham Books.
- Prosser, J. (2011). Visual methodology: Towards a more seeing research. In N. Denzin & Y. Lincoln (Eds.), *The SAGE handbook of qualitative research* (4th ed., pp. 479–495). Los Angeles: Sage.
- Prosser, J., & Loxley, A. (2008). Introducing visual methods. ESRC National Centre for Research Methods review paper. *October*, NCRM/010.
- Satchwell, C. (2005). Literacy around the clock: An examination of the clock activity. In J. Caldwell (Ed.), *What a difference a pedagogy makes: Researching lifelong learning and teaching. Proceedings of 3rd International CRL Conference (2005)*. Glasgow: Centre for Research in Lifelong Learning.
- Scollon, R., & Wong Scollon, S. (2004). *Nexus analysis: Discourse and the emerging internet*. London: Routledge.
- Senft, T. (2013). Microcelebrity and the branded self. In J. Hartley, J. Burgess, & A. Bruns (Eds.), *A Companion to new media dynamics* (pp. 346–354). Malden: Wiley.
- Shohamy, E., & Gorter, D. (2009). *Linguistic landscape: Expanding the scenery*. New York: Routledge.



---

# Narrative Inquiry and Multicultural Education

Jubin Rahatzad, Hannah Dockrill, and JoAnn Phillion

---

## Abstract

Narrative as a methodological approach to inquiry has a long history of making meaning for the human social world. Multicultural education began in North America as an extension of the mid-twentieth-century civil rights movement and has been taken up globally as a vehicle to include the voices of historically marginalized populations. The intersections of narrative inquiry and multicultural education, narrative multiculturalism and cross-cultural inquiry, are used by educational scholars as an approach to understanding educational issues of social (in)justice and social (in)equity. The interdisciplinary natures of narrative inquiry and multicultural education have allowed multiple disciplinary perspectives to intermix interpretations of lived experiences. How cross-cultural experiences are storied has opened spaces for new methodological possibilities. Narrative multiculturalism thrives on learning from examination of social relations. Within this understanding, multiculturalism within narrative inquiry is not something to be defined, allowing for fluidity in the conceptualization of what constitutes narrative multiculturalism.

This chapter reviews the origins of narrative inquiry and multicultural education with a focus on narrative multiculturalism as a research methodology in educational research. Then a brief overview of influential works is provided. Next, examples of current work in the field are examined. The review of previous

---

J. Rahatzad (✉) • H. Dockrill (✉) • J. Phillion (✉)  
College of Education, Purdue University, West Lafayette, IN, USA  
e-mail: [jrahatz@purdue.edu](mailto:jrahatz@purdue.edu); [hdockri@purdue.edu](mailto:hdockri@purdue.edu); [phillion@purdue.edu](mailto:phillion@purdue.edu)

work and current work presents insights into the productive difficulties of narrative multiculturalism. Finally, possible future pathways for narrative inquiry and multicultural education are discussed. Throughout, examples are provided of the research methods that might be used with narrative multiculturalism.

---

### Keywords

Narrative Inquiry • Methodology • Multicultural Education • Critical • Reflection • Teacher Education

## Contents

Introduction .....	408
Early Developments .....	409
Major Contributions .....	410
Work in Progress .....	413
Problems and Difficulties .....	415
Future Directions .....	416
Cross-References .....	417
Related Articles in the Encyclopedia of Language and Education .....	418
References .....	418

---

## Introduction

Narrative inquiry is a research methodology used in many disciplines, based on the foundational assumption that people create meaning of their lived experiences through the construction of narratives or stories. Narrative inquiry is a context-specific methodology and, as such, does not follow a step-by-step approach in terms of research methods. Offering a prescribed approach to the methods of narrative inquiry is counter to the aims of the research methodology, which is built on developing relationships with participants rather than following definite instructions. For researchers attempting to understand the experiences of their participants, narrative inquiry involves being in relation to participants, joining the flow of participants' lives, rather than approaching research with a predetermined schema.

There are multiple general methods of research within narrative inquiry that involve the collection of oral, observational, and written narratives or stories. Data comprises interviews, stories, conversations, journals, letters, field notes and observations, biographies and autobiographies, and personal and social artifacts. The focus of narrative inquiry is less about the stories that people tell and more about the meaning and importance with which those stories are imbued by those who tell them (Hendry 2007). How language, in all its forms, construes meaning and is given meaning is of importance in narrative inquiry. Key features of narrative inquiry are the focus on lived experiences, the length and depth of time spent in the field, transparency of researcher positionality, and collaboration with participants. Experiences are understood on their own terms rather than being forced into predetermined categories and/or theoretical frames (Clandinin and Connelly 2000).

## Early Developments

Hendry (2010) suggests that narrative inquiry is not a new research method but is one that humans have always employed through asking questions and making meaning. Because human beings make meaning through narrative and because all inquiry or research is understood as an attempt of meaning making, “all inquiry is narrative” (p. 72). Hendry (2010) asserts, “narrative is the first and oldest form of inquiry. . . all research traditions originate from narrative” (p. 72). Narrative inquiry has found fertile ground within the social sciences and has been used to explore the phenomena of lived experiences in anthropology, psychology, psychotherapy, psychiatry, social work, sociology, theology, ethnography, history, and organizational theory, among other fields.

Within educational research, Clandinin and Connelly (2000) were among the first scholars to delineate a narrative approach and to maintain a program of narrative research (Phillion et al. 2005). Illustrative of the interdisciplinary nature of narrative inquiry, Clandinin and Connelly (2000) cite as major influences Dewey (1938/1997) in the field of education, Johnson (1987) and MacIntyre (1981) in philosophy, Geertz (1995) and Bateson (1994) in anthropology, Czarniawska (1997) in organizational theory, Coles (1989) in psychiatry, and Polkinghorne (1988) in psychology. Clandinin and Connelly were at the forefront of bringing narrative inquiry into teacher education and advocated its use because “if we understand the world narratively, as we do, then it makes sense to study the world narratively” (p. 17).

As well as teacher education, in which Clandinin and Connelly have done the majority of their research, narrative inquiry has also been taken up in many different educational fields, such as the study of teaching and learning, writing, science education, curriculum studies, school reform, language teacher knowledge, educational psychology, black feminist studies, educational philosophy, and minority student education. Narrative researchers place themselves in the midst of their research in an attempt to recognize the ambiguity and flux of their understandings as researchers in relation to their *selves*, their participants, and their research contexts. In developing understanding of the storied lived experiences of research participants, narrative researchers often take critical stances while avoiding assertions of what counts as “valid” or “invalid” knowledge. Stories come into contention with one another, sometimes offering irreconcilable differences, which can be examined for understandings based on tension as a productive space. Narrativists denounce generalizable knowledge in favor of the meanings made by people living their lives, in all of its social messiness. Narrativists do not impose theory or their own hypotheses a priori; instead, narrativists attempt to observe through an acknowledgment of the self as part of the study.

Building on the work of Clandinin and Connelly (2000), scholars have brought narrative inquiry into multicultural education. Multicultural education in North America grew out of the civil rights movement of the mid-twentieth century and aims to include historically marginalized and oppressed groups. Multicultural issues within educational research and teacher education were foregrounded in the 1990s, after two decades of institutional recognition of the importance of

multicultural education. The previous denial of the political nature of inquiry was dismantled by a new awareness and process of meaning making that sought to include historically marginalized and oppressed perspectives. Early research in multicultural education raised awareness of the importance of culture in curriculum, the role culture plays in learning styles, and the importance of recognizing cultural, racial, ethnic, linguistic, and other components of social diversity in all aspects of education. The emergence of multicultural issues within narrative research is due, in part, to recognition of coloniality, where human experience is understood through migratory stories. Varied lived experiences inherently produce varied stories and diverse ways of knowing. Language concerns based on lived experiences include the domination of English and the value of multilingual understandings. Narrative inquiry in multicultural education does not simply extol individuals' stories without consideration of the larger societal context in which those stories are formed and shaped.

A multicultural perspective through narrative aims to include historically excluded voices and interpretations in a move toward equitable social relations, broadly defined as social justice. Such a multicultural move opens up ignored, forgotten, erased, and hidden spaces as a means to transform dominant and hegemonic cultures and ideologies. Two key strands have grown from the intersection of multicultural education and narrative inquiry that both address issues of social justice and marginalized people: narrative multiculturalism (Phillion 2002) and cross-cultural narrative inquiry (He 2002). The formal conceptualization of narrative multiculturalism has paved a path for many scholars to justify their research foci. Narrative multiculturalism asserts a social justice purpose, moving toward equitable social relations.

---

## Major Contributions

Phillion (2002) employed narrative inquiry in the context of multicultural education, having developed the concept of narrative multiculturalism through an in-depth study of an immigrant teacher working in a culturally diverse classroom in Canada. Both phenomena and method, narrative multiculturalism is a fusion of narrative thinking and multicultural thinking, envisioned as a human-centered, experiential, reflective, and relational way of thinking about, researching, and understanding everyday phenomena.

Narrative multiculturalism requires more than simply interviewing or observing a research participant. Researchers using narrative multiculturalism critically examine the sociopolitical context in which their research is situated. In addition to the frequent types of data collected in qualitative research (e.g., interviews, field notes and observations, and conversations), narrative multiculturalism requires an examination of local media accounts, public policies, and documents such as journals, letters, and personal and social artifacts. The types of data collected are specific to the context of the research being done. For example, for her research in a Canadian school, Phillion (2002) searched the school archives and examined old school

records, diaries kept by the school's principals, and meetings of school board meetings in order to understand the discourse and attitudes about immigration and nonwhite teachers in that particular research context.

He (2002) developed a narrative approach to multicultural issues, similar to narrative multiculturalism, that she called cross-cultural narrative inquiry. Building on the work of Clandinin and Connelly (2000) by focusing on cross-cultural experiences, he focused on her positionality as a non-Westerner in a Western society and examined the cross-cultural experiences of Chinese educators in North American schools, pushing narrative multiculturalism into the sphere of social analysis within educational research. She argued that "cross-cultural narrative inquiry has a close-to-life, reflective and fluid, contextualized and historicized quality that enables us to explore and portray the shifting, often paradoxical, nature of our cross-cultural lives and cross-cultural identities" (p. 517). Similar to Phillion (2002) and Hendry (2010), the complexities of multicultural stories can never be holistically storied; instead, there is an acknowledgment of positionality. The notion of cross-cultural experiences opens up inquiry to an individual's plurality in terms of identity and the experiences that even monocultural individuals can have when interacting with cultural others.

Valenzuela (1999) and Carger (1996) provide early examples of multicultural approaches to narrative inquiry, although neither used the term *narrative multiculturalism* to describe their work. Valenzuela's work is an ethnographic study, and Carger classifies her work as narrative (but not explicitly multicultural). However, as Hendry (2010) and Barone (2010) have asserted, narrative is part of most, if not all, qualitative inquiry. Thus, Valenzuela's and Carger's studies are considered as significant multicultural narratives that introduce the concept of "othered" experiences within US educational systems. Valenzuela and Carger have both contributed to foundational work in narrative multiculturalism through the methodological features of their scholarship. This includes the appreciation of language differences and the impact of difference on participants' lived experiences. Both are deeply involved in their participants' lives and passionately committed to revealing the stories and lived experiences of minority students. This involves collecting data through long-term immersion in the research context.

Valenzuela (1999) analyzes the discursive and material oppression of US-Mexican students, offering an example of an advocative approach to research in a multicultural setting. Valenzuela demonstrates, through storied experiences of Mexican-American students, the imbalance of power between Mexico and the USA within the international arena and reveals an understanding of the human experience within oppressive circumstances as the postcolonial reality of supposedly modernist egalitarian conditions. The attitudes toward the Spanish language in dominant US discourse are detailed as an oppressive form of social control as manifested through schooling. In doing so, she advances an understanding of research and society that prioritizes the import of relational dynamics. US-Mexican youth represent an oppressed population in the USA, and Valenzuela examines her participants' social positionality and her own standing in relation to her participants and the influence the research process has on her perspective.

This methodological approach involves the method of immersion in the life of the participants, not only listening to stories but also synthesizing and contextualizing them. Valenzuela collected data for 3 years, in which time she was fully immersed in school and community events. Her data included but was not limited to observations and conversations; group and individual interviews with multiple stakeholders such as students, teachers, parents, administrators, and community leaders; attendance at numerous school, community, political, and church meetings, functions, sporting events, and activities; archival records; school records and memoranda; and student assignments.

Carger (1996) offers a long-term narrative account of the storied experiences of Alejandro, a Mexican-American student operating within a dominant, whitestream US system. After initially working with Alejandro as his ESL tutor, Carger takes on the role of researcher as advocate. She describes Alejandro's family, neighborhood, and community; his relationship with peers, teachers, and school officials; and the role of religion in his family's life. Her detailed narrative takes into account the multiple, complex influences that shape the lives and experiences of minority students. Carger contributes to the work on bilingual and English language learner (ELL) students and to multicultural education. Carger's relationship with Alejandro provides readers with insight into the multilayered struggle of the minority experience in the USA through a focus on the human experience. Whereas earlier research in multicultural education was abstract and distant with less focus on the lived experiences of minorities, narrative multiculturalism infused multicultural education with examples of personal stories and in-depth understanding of lived experiences.

As with Valenzuela, Carger's research methods involved long-term (over 2 years) immersion in her research site and her participant's life. In that time, Carger became more than a researcher; she was also an advocate, family friend, and confidant. She attended parent-teacher conferences and meetings with the school principal and other school personnel, translating on behalf of Alejandro's parents, shared family meals and outings together, and attended Alejandro's eighth-grade graduation ceremony. There are more recent examples of narrative multiculturalist research that offer nuanced understandings of how humans make meaning across a variety of social contexts.

One such example is how Chan (2009) has continued the exploration of the intersection between narrative inquiry and multicultural education within the context of North American schools. Chan examines the lives of immigrant, minority, and ELL students in North America and uses students' narratives to understand many influences that shape students' educative experiences. Chan suggests that providing opportunities for immigrant, minority, and ELL students to share their narratives within the regular school curriculum allows teachers and researchers to know and understand more about students' lived experiences, which can result in the use of more culturally relevant pedagogy and personalized curricular activities. As students from multiple backgrounds share their stories and cultural knowledge, educators can develop the capacity for understanding across cultural difference. The use of narrative is a form of multicultural education. In a long-term, school-based study, Chan (2009) describes the experiences of Ai Mei, a Chinese immigrant student in Canada,

whom Chan spent 2 years observing, conversing with, and storying her experiences. The contribution that in-depth, personal work makes to narrative multiculturalism is summarized by Chan:

This examination of the intersection of home, school, and ethnic community influences in Ai Mei's life provided a glimpse of the challenges immigrant or minority students might encounter as they negotiate a sense of ethnic identity. . . . The stories highlight the potential for conflict when immigrant students have values shaped by interaction with family and members of their ethnic community as well as values shaped by interaction with peers, teachers, and other members of their North American school communities. (p. 120)

A narrative approach to research in multicultural education can bring to light the difficulties of supporting immigrant students in North American schools and contribute to understandings of multicultural education.

Trahar (2011, 2013) has made a significant contribution to narrative multiculturalism by providing an international perspective beyond North America. Trahar's (2011) edited book includes chapters on teaching narrative inquiry in a Chinese community in Hong Kong, the influence of academic work on professional lives for university lecturers in Sweden, and the cross-cultural work between professor and doctoral student in North America. Trahar's (2013) edited collection includes topics such as leadership styles of Asian women, the deaf community in the UK, voluntary celibacy in Malta, multiculturalism in elementary education in Cyprus, administrators in Ghanaian higher education, teacher identities in Hong Kong, and the interplay of narratives between a Catalan primary teacher and Chilean educational researcher. The range – both geographically and epistemologically – of these collections illustrates the ways in which narrative inquiry is being used globally by researchers from a variety of backgrounds. Albeit new in form, narrative inquiry from non-North American backgrounds has been ongoing for decades in Latin America.

Narrative inquiry from Latin American backgrounds has been and is accessible to North American readers in the form of *testimonios* by members of oppressed populations (e.g., Alvarado and Benjamin 1989; Menchú and Burgos-Debray 1984). *Testimonios* represent intranational culture differences in the historical context of coloniality. This is a form of narrative multiculturalism that is not labeled as such but has been a form of representing diverse lived experiences. *Testimonios* provide the research participant an opportunity to have a more direct voice in the research process, working as a coresearcher in collaboration with a researcher.

---

## Work in Progress

There are a number of new ways in which narrative multiculturalism is being employed. Rosiek and Atkinson (2007) have stated that “the styles and formats used in . . . narrative reports have remained nearly as unique as the scholars and teachers conducting the research” (p. 500). For example, currently, a major multicultural trend in narrative inquiry is the examination of multicultural contexts in

China. This emergent area of interest is representative of an increasing number of non-North American scholars engaging in narrative multiculturalism. Much narrative multiculturalism work being done in non-English-speaking contexts is often not readily accessible to English-speaking scholars; therefore, it is difficult to ascertain the work that is being done in all contexts. Scholars situated outside of North America are increasingly conducting transcultural and cross-cultural narrative inquiries. One example of an international cross-cultural narrative study comes from Howe and Xu (2013) who illustrate how scholars from various national origins engage their identities as researchers while working and living in countries to which they emigrated. This includes North American whites living outside of North America in nonwhite contexts. This study also demonstrates the developing autoethnographic perspective, which considers the role of the inquirer within the constructed narrative, including language concerns.

Much autoethnographic work is related to the philosophy developed by Phillion et al. (2005) and is like Grumet's (1987) approach to exploring autobiographical narrative forms in education. The proliferation of autobiographical work, or the inclusion of autobiographical pieces within narrative studies, has been embraced by narrative multiculturalists as necessary to understanding relationality in various social contexts. Grumet argues, "The politic of narrative is not then, merely a social struggle, but an ontological one as well. We are, at least partially, constituted by the stories we tell to others and to ourselves about experience" (p. 322). Narrative, as a maturing field, continues to move toward a constellation of understandings from various lived experiences. Simultaneously, the wide employment of personal level narrative analysis has opened space for critical scholars to question the ethics around storying any experience (Hendry 2010).

A more recent turn to narrative in educational research has occurred among postcolonial educational inquirers. Fox (2008) has observed that power dynamics, globally and locally, necessitate ethical considerations through narrative inquiry. Such considerations suggest a disruption of the dominant researcher's/reader's gaze, per postcolonial understandings, and a move toward "an awareness of the cognitive, semiotic, experiential, ethical and hermeneutic filters through which we interpret and define our world" (p. 346). This assertion is in response to the plethora of woven narratives that privilege voices without questioning social positionality, including systemic privileges and restraints. Included in Fox's perspective is the concern of English's dominance globally and the consequences of marginalizing other major world languages and lesser known languages. Convery (1999), for example, is critical of elevated teacher voices in narrative work as a concern around issues of equity and equality. It is the narrative researcher's responsibility to be attuned to issues of discrimination, prejudice, marginalization, exclusion, and oppression. Fox argues this point through a postcolonial examination of the state of narrative inquiry, which fits within the multiculturalist frame. Researchers have "to be aware of all the ways in which we filter the information received through narrative" (p. 341). Fox proposes that a conceptual map of how information is filtered through narrative inquiry may aid the awareness that narrative multiculturalism seeks.



## Problems and Difficulties

Narrative inquiry as a research methodology has contributed to understanding multicultural education issues, but many problematics remain. Yet, issues and concerns continue to be raised within and outside the field. As a research method, there are a number of challenges. One critique of narrative inquiry, which has been applied to qualitative research in general, is that it is too “soft.” Eisner (1993) highlights this critique in the debate over the scientific “rigor” of educational research. Carger (1996) responds to critiques of narrative inquiry as being “soft” by arguing for a validation of her participant’s story, a Mexican-American example of immigrant experiences in the USA and US schools, on its own grounds.

An integral element of employing narrative inquiry in multicultural education research is the need for researchers to become embedded in the lives of their participants. Yet, while this is necessary component for data collection, immersion can create problems and challenges. Researchers can “fall in love” (Clandinin and Connelly 2000, p. 81) with their participants and become heavily involved in the flow of participants’ lives to the degree that the understanding of power dynamics between researcher and participant is blurred or ignored. This has ethical implications for how research is conducted. Clandinin and Connelly caution that while researchers “must become fully involved, must ‘fall in love’ with their participants, yet they must also step back and see their own stories in the inquiry” (p. 81). They respond to this risk by suggesting that researchers continue to faithfully construct field texts and collect data. Through this, researchers are able to move “back and forth between falling in love and cool observation” (p. 82). The implications of the researcher’s positionality must not be ignored because of ethical considerations.

In terms of relational concerns within narrative inquiry, Convery (1999) suggests that a preferred identity is often “created rather than revealed” (p. 138) through narrative in an attempt to make the teacher (in this case) a heroic, moral character. The default celebration of teachers’ voices does not account for the imposed perspective of the inquirer. In the case of teacher participants, what is considered meaningful is taken within a frame that often does not recognize the influence of dominant norms. Convery also cautions against the inquirer’s desire, conscious or unconscious, for using narrative as a form of “short-term therapy” (p. 142). The relational aspect of narrative inquiry requires an awareness that considers the inquirer as situated and in relation to participants and contexts. However, it also requires a questioning of what stories are deemed important by the inquirer and why certain ways of meaning making are foregrounded.

Due to the relational nature of narrative research, the researcher’s own experience becomes part of the inquiry. In this regard, narrative inquiry has been accused of being an exercise in self-absorbed navel-gazing as researchers become overly concerned with their own place in the research. Clandinin and Connelly (2000) suggest that “to dismiss the criticism that narrative inquiry is overly personal and interpersonal is to risk the dangers of narcissism and solipsism” (p. 181). They suggest that researchers develop what they call “wakefulness,” an awareness cultivated in openness to diversity and dialogue in order to guard against these risks.

However, they go on to say, “We need to be awake to criticism but not necessarily accepting of it” (p. 183). A relational balance can be developed through constant self-reflection by the researcher.

Another possible problem is blindness to coloniality as it impacts lived experiences. Many educational scholars who employ narrative multiculturalism fail to address the historical and contemporary colonizing mission of academic research. Narrative multiculturalism has opened up pathways to be taken for richer and deeper understandings of global social relations; however, narrative multiculturalism is infused with traces of hegemonic academic norms, similar to other methodological traditions. The foundations of narrative multiculturalism lack recognition of coloniality, complacently undertake superficial multiculturalist aims, and assimilate alternative funds of knowledge to normalized epistemological hierarchies within qualitative research and science generally. While professing to include “othered” voices, this work can privilege researchers’ perspectives and epistemological trajectories. The inclusion of knowledge production from diverse sources based on multiple epistemological foundations can guard against such concerns. The consideration of historical oppressions must be evident in narrative multicultural work.

Within narrative multiculturalism, historically oppressed groups face the task of legitimizing their funds of knowledge. The colonizing impact of narrative inquiry needs to be addressed in order to move beyond a superficial celebration of difference. Hendry (2007) recognizes the rewards and risks of narrative multiculturalism: “As researchers we construct lives by reducing them to a series of events, categories, or themes and then put them back together again to make up a whole called *narrative*. Thus by constructing narratives we not only ultimately erase part of our lived experience but also impose a particular way of thinking about experience” (p. 492).

---

## Future Directions

Narrative multiculturalism, as a methodological approach to research, has various pathways that can shape the future of how meaning is made of social phenomena: past, present, and future. From Hendry’s (2010) claim that all inquiry is narrative to Fox’s (2008) promotion of a postcolonial stance within narrative inquiry, what is considered within the purview of multiculturalism remains open to various approaches that can continue work toward social justice.

New directions within narrative multiculturalism and cross-cultural narrative are increasingly seeking out the roots of human meaning making across a plethora of contexts. Hendry (2010) asserts that “*Narrative* means ‘to account’ and is derived from the term *gno*, meaning to know. The oral storytelling traditions of earliest man were narrative inquiries that sought to address questions of meaning and knowing. From the beginning, narrative embodied multiple ways of knowing” (p. 72). The future of narrative multiculturalism and cross-cultural narrative is moving toward other ways of knowing, drawing from historically excluded funds of knowledge and approaches to knowledge construction. As narrative inquiry proliferates through multicultural and cross-cultural lenses, lived experiences and personal

understandings increasingly contribute to understandings of social realities. Narrative inquiry is evolving based on contextual imperatives as a decentering of enlightenment rationality and alternatives to scientific reasoning. This is a critical shift in narrative inquiry that can contribute to the broadening of human knowledge.

Historically excluded voices and epistemologies represent new pathways for narrative multiculturalism and cross-cultural narrative. Fox (2008) offers a rethinking of who has the “right” to speak through narrative multiculturalism, the relationship between the inquirer and the research participant(s), and the issue of the legitimized narrator. This questions not only who can be heard but also believed. Fox proposes mindfulness as a new direction for inquirers to genuinely listen and work through gnoseological understandings, in addition to epistemological and ontological considerations. “Resituating all inquiry as narrative, as opposed to characterizing narrative as one particular form of inquiry, provides a critical space for rethinking research beyond current dualisms and bifurcations” (Hendry 2010, p. 72). In this sense, narrative multiculturalism is an extension of narrative inquiry within education with a desire to push the boundaries of research methodologies and ultimately knowledge construction.

Inquiry at the border between dominant ways of knowing and historically excluded ways of knowing represents a major shift in the focus of narrative multiculturalism and cross-cultural narrative. Knowledge constructed at epistemological borders can address global power dynamics and engage the ways of knowing that are rooted in the intersectionalities and complexities of “borderlands” of knowing (Trahar 2011). Ultimately, narrative multiculturalism is an exploration of how the social world is experienced by a multitude of humans. Connections can be made to group and organization (e.g., ethnic, regional, nation-state, NGO, governmental) level experiences based on how individual humans come to know in relation to one another.

Phillion et al. (2005) have extended the focus of narrative to multicultural contexts, fostering a proliferation of work that embodies narrative multiculturalism. Hendry (2010) asserts that knowledge construction through varied lived experiences, exploring the borders of experience and epistemology, is not separate or distinct from knowledge constructed through positivistic scientific inquiry. Narrative multiculturalism and cross-cultural narrative deepen and broaden understandings of the social world to the benefit of all people. Meaning is produced through a multicultural lens as the inquirer constructs narratives that explore meanings derived from lived experiences. The intersection of narrative inquiry and multicultural education has produced two strands, narrative multiculturalism and cross-cultural narrative, as a point of departure for future research.

---

## Cross-References

- ▶ [Language Teacher Research Methods](#)
- ▶ [Methods in Multilingualism Research](#)
- ▶ [Research Approaches to Narrative, Literacy, and Education](#)

## Related Articles in the Encyclopedia of Language and Education

Nelson Flores and Jeff Bale: [Sociopolitical Issues in Bilingual Education](#). In Volume: Bilingual and Multilingual Education

---

## References

- Alvarado, E., & Benjamin, M. (1989). *Don't be afraid, gringo: A Honduran woman speaks from the heart: The story of Elvia Alvarado*. New York: Harper & Row.
- Barone, T. (2010). Commonalities and variegations: Notes on the maturation of the field of narrative research. *The Journal of Educational Research*, 103(2), 149–153.
- Bateson, M. C. (1994). *Peripheral visions: Learning along the way*. New York: Harper Collins.
- Carger, C. L. (1996). *Of borders and dreams: A Mexican-American experience of urban education*. New York: Teachers College.
- Chan, E. (2009). Living in the space between participant and researcher as a narrative inquirer: Examining ethnic identity of Chinese Canadian students as conflicting stories to live by. *The Journal of Educational Research*, 103(2), 113–122.
- Clandinin, D. J., & Connelly, F. M. (2000). *Narrative inquiry: Experience and story in qualitative research*. San Francisco: Jossey-Bass.
- Coles, R. (1989). *The call of stories: Teaching and the moral imagination*. Boston: Houghton Mifflin.
- Convery, A. (1999). Listening to teachers' stories: Are we sitting too comfortably? *International Journal of Qualitative Studies in Education*, 12(2), 131–146.
- Czarniawska, B. (1997). *Narrating the organization: Dramas of institutional identity*. Chicago: University of Chicago Press.
- Dewey, J. (1938/1997). *Experience and education*. New York: Touchstone.
- Eisner, E. W. (1993). Forms of understanding and the future of educational research. *Educational Researcher*, 22(7), 5–11.
- Fox, C. (2008). Postcolonial dilemmas in narrative research. *Compare*, 38(3), 335–347.
- Geertz, C. (1995). *After the fact: Two countries, four decades, one anthropologist*. Cambridge: Harvard University Press.
- Grumet, M. R. (1987). The politics of personal knowledge. *Curriculum Inquiry*, 17(3), 319–329.
- He, M. F. (2002). A narrative inquiry of cross-cultural lives: Lives in the North American academy. *Journal of Curriculum Studies*, 34(5), 513–533.
- Hendry, P. M. (2007). The future of narrative. *Qualitative Inquiry*, 13(4), 487–498.
- Hendry, P. M. (2010). Narrative as inquiry. *The Journal of Educational Research*, 103, 72–80.
- Howe, E., & Xu, S. (2013). Transcultural teacher development within the dialectic of the global and local: Bridging gaps between east and west. *Teaching and Teacher Education*, 36, 33–43.
- Johnson, M. (1987). *The body in the mind: The bodily basis of meaning, imagination, and reason*. Chicago: University of Chicago Press.
- MacIntyre, A. (1981). *After virtue: A study in moral theory*. Notre Dame: University of Notre Dame Press.
- Menchú, R., & Burgos-Debray, E. (1984). *I, Rigoberta Menchú: An Indian woman in Guatemala*. London: Verso.
- Phillion, J. (2002). *Narrative inquiry in a multicultural landscape: Multicultural teaching and learning*. Westport: Ablex.
- Phillion, J., He, M. F., & Connelly, F. M. (Eds.). (2005). *Narrative and experience in multicultural education*. Thousand Oaks: Sage.
- Polkinghorne, D. E. (1988). *Narrative knowing and the human sciences*. Albany: State University of New York Press.

- 
- Rosiek, J., & Atkinson, B. (2007). The inevitability and importance of genres in narrative research on teaching practice. *Qualitative Inquiry*, 13(4), 499–521.
- Trahar, S. (Ed.). (2011). *Learning and teaching narrative inquiry: Travelling in the borderlands*. Philadelphia: John Benjamins.
- Trahar, S. (Ed.). (2013). *Contextualising narrative inquiry: Developing methodological approaches for local contexts*. New York: Routledge.
- Valenzuela, A. (1999). *Subtractive schooling: U.S.-Mexican youth and the politics of caring*. Albany: State University of New York.

---

# Language Teacher Research Methods

Manka M. Varghese and I-Chen Huang

---

## Abstract

Research methods and approaches to study language teachers have been aligned with theories underpinning language teacher education. Earlier views on teaching were of a seamless relationship with one's professional training, and thus, studies of second language classrooms primarily used quasiexperimental methods and observation schemes in order to identify the effectiveness of one's pedagogical practice. This behaviorist model of teaching was critiqued due to its insufficient attention on teachers' mental lives and actions; therefore, a qualitative approach that highlights the role of teachers in interaction with students and their environment has prevailed more recently. Qualitative data collection strategies (e.g., fieldnotes, interviews, reflective writings, or stimulated recall) aim to make tacit teachers' cognitive processes visible and provide a descriptive account of their practices. Ensuing methods were primarily narrative and based in teacher research. These inquiries not only allowed teachers to examine their own classrooms, but helped them transform themselves at a personal and sociopolitical level. Nevertheless, both (1) how to understand and view language teacher knowledge and (2) how to conceptualize language teacher learning, present methodological challenges in studying these phenomena. A pressing issue is how to connect language teaching with learning outcomes. Future research will use mixed-methods to examine multiple teaching variables and their effects on students' achievement, and will also adopt a critical approach to understand language teachers and teaching, such as studying and understanding language teacher identity.

---

M.M. Varghese (✉)

College of Education, University of Washington, Seattle, WA, USA

e-mail: [mankav@u.washington.edu](mailto:mankav@u.washington.edu)

I.-C. Huang

Department of English, Wenzao Ursuline University of Languages, Kaohsiung, Taiwan

e-mail: [98032@mail.wzu.edu.tw](mailto:98032@mail.wzu.edu.tw)

---

**Keywords**

Research methods • Language teacher education • Professional development • Teacher knowledge

**Contents**

Introduction .....	422
Early Developments .....	422
Major Contributions .....	423
Work in Progress .....	426
Problems and Difficulties .....	427
Future Directions .....	429
Cross-References .....	430
Related Articles in the Encyclopedia of Language and Education .....	430
References .....	430

---

**Introduction**

The study of language teachers is a relatively recent area of research that focuses on how teachers learn to teach, how they teach, and who they are as individuals and professionals. Over two decades ago, Richards (1990) observed that there had been “little systematic study of second language teaching processes that could provide a theoretical basis for deriving practices in second language teacher education” (p. 3). The field has developed since then and has become an important area of study in language and education. It has included mainly qualitative methods in classroom settings used to study language teachers by outsiders and those, such as action research used by language teachers themselves to study their own classrooms and other qualitative studies of teachers across different settings, such as those describing teachers’ professional trajectories.

---

**Early Developments**

Early forays into analyzing second-language classrooms focused on attempts to evaluate student language learning through the identification of the best method or a set of teacher behaviors. Chaudron (1988) outlined four methods of research into second-language classrooms, which are useful to consider here: (1) psychometric analysis, a quasiexperimental method that uses pre- and postanalysis of classrooms with experimental and control groups; (2) interaction analysis, an observation scheme of the social interactions in the classroom; (3) discourse analysis, an observation scheme of the linguistic interactions in the classroom; (4) ethnographic analysis, an analysis of the classroom based on interpretation, including interviews with and observations of participants. The language teacher in the first three types of analysis was viewed as transmitter of a particular method, and the focus was on teacher behaviors and student outcomes. In the fourth approach, the emphasis was

more of a holistic understanding of teacher and student interactions and motivations, which was an approach that was sustained in the field.

Two often-cited, early studies of second-language classrooms used mainly psychometric methods to examine the relationship between language teaching and student outcomes: (1) the Pennsylvania project that attempted to compare the audiolingual method with traditional methods by looking at the test scores of students in different programs at a secondary school (Smith 1970) and (2) Politzer's (1970) study of secondary French classrooms where the frequency of certain techniques (different types of drills) used by teachers. With the onset of communicative language teaching, many of these studies were conducted for purposes of teacher training and evaluation, using standardized and analytic observation frameworks, with the goal of removing the bias of the observer. A number of these derived from first-language classroom analysis, but a widely used example of this in second-language teaching is Communicative Orientation of Language Teaching (COLT) (Fröhlich et al. 1985). Two observers visited the classroom to identify teaching techniques related to communicative-oriented or form-focused principles. This observation scheme allows for analysis of communicative variables in the classroom, such as classroom activities (tasks, participation structures) and classroom language. The COLT demonstrates the use of observation instruments rather than experimental studies to explore linguistic and social interactions. Much of the research on language teaching then remained confined to the classroom setting as opposed to including factors outside the classroom.

---

## Major Contributions

What was viewed as a simplistic cause-effect model in the earlier process-product framework was challenged by, among others, Nunan (1988) and van Lier's (1988) books on ethnography in second-language classrooms. These scholars provided a conceptual rationale for addressing the complexity of language teaching. In turn, this shift moved language teacher research into a qualitative domain and provided a central role for the teacher's perspective. Research in language teaching, thus, moved from a behaviorist model based on teacher triggers and student behaviors and outcomes as illustrated in some of the examples mentioned earlier, to an integrated and multifaceted understanding of teaching and learning. Predominantly qualitative and classroom-based, there have been two major strands of this research aim. The first aims to study language teachers' professional development, beliefs, decisions, and actions independently and also in interaction with their learners; the second attempts to provide ways for language teachers to study and document their own practices.

It is useful to frame the first set of studies within Freeman and Johnson's (1998) call for a reconceptualization of the knowledge base of language teacher education. Freeman and Johnson outlined the knowledge base of what language teachers should know as including the following: teacher as learner, the social context of schooling, the professional environment of the teacher, and the actual practices and activities of



teaching and learning the teacher is involved in. As a result, this shift in the understanding of language teaching naturally called for research into language teaching and teachers to be conducted across diverse settings (beyond the classroom), and to understand the process from the view of different participants. Within this framework, teacher learning is conceptualized “as normative and lifelong” (Johnson and Golombek 2003, p. 730).

Two volumes of language teaching and teacher practice also reflect this reconceptualization. Bailey and Nunan (1996) describe their volume as containing studies that have been conducted naturalistically, that is, where “naturally occurring events are studied” (p.1), as well as ones having multiple data sources (e.g., fieldnotes and interviews) so that triangulation can be achieved. This volume provides 19 qualitative studies, from teacher thinking and interpretation to classroom studies, from ones that are based on curriculum changes to those that are largely situated within their sociopolitical context. An example of a study examining teacher thinking is an investigation into why English as a second language (ESL) teachers depart from their original lesson plans where Bailey (1996) found that reasons why teachers chose to do so were to further the lesson, accommodate student learning styles, or maximize students’ participation. Additionally, the studies in this volume originate from different countries and also display a range of different types of language teaching, from ESL to English as a foreign language (EFL), and from bilingual to world language/foreign language teaching (such as van Lier’s (1986) description of classroom teaching influenced by a bilingual education project in the Peruvian Andes). The methodological orientation of Bailey and Nunan (1996) is shared by the other volume of Freeman and Richards (1996). Freeman and Richards aim to discuss language teacher learning, broadly defined as “how people learn to teach languages” (p. 2). By unfolding experiences of student teachers and teachers, Freeman and Richards collected inquiry-based accounts of professional development. The focus on teachers themselves is conducive to view teaching, which should be beyond one’s acquisition of disciplinary knowledge.

Similar to other areas of education in the late 1980s, teacher learning and teacher cognition became the focus of inquiry for language teacher research in the 1990s. This new focus places teachers at the center of the process of understanding language teaching. Most of this work can be described as second-order research (data are viewed as evidence that has to be interpreted through the participants’ perspectives). Such studies have been mainly qualitative and interpretive, ranging from understanding teacher decision-making through different data elicitation techniques and analysis (interviews, narrative studies, journal studies, discourse-based studies, questionnaires, and ethnographic analysis). Examples of these include Johnson’s (1996) rendering of how one preservice teacher experiences tensions between her vision of the teaching and the realities of classroom teaching during her practicum, and Pennington’s (1996) description of how a group of secondary English composition teachers in Hong Kong adopt a process approach to writing. The book edited by Barnard and Burns (2012) offers a rich discussion of research methods in teacher cognition. Each chapter is coauthored in an international context (e.g., Malaysia). A novice researcher not only reports the study designs, but narrates one’s data

collection experience, followed by a leading scholar who comments on how each method should be conducted and what problems can be anticipated. An example of the collaboration is Li's think aloud (TA) study on tutors' beliefs and practices about assessing college students' compositions in New Zealand. The difficulties of conducting a TA session were discomfort that interfered one who talked aloud in the presence of a researcher and cognitive demands for participants who simultaneously verbalized feedback and marked writings. Farrell commented that videotaping TA could minimize the effects of a researcher on one who accounts thinking processes. Training should be provided for participants to know about TA procedures.

Two larger studies of language teacher cognition are also of import. Woods (1998) examined cognitive processes of decision-making through ethnographic methods. Woods himself clarifies that he does not consider his study fully ethnographic; he observes that a study that would have been ethnographic in its goal (rather than solely with regard to methods) would have focused on describing the shared subculture and processes of the teachers. Woods analyzed how decisions were made by eight ESL teachers at four universities in Canada in their courses and lessons through ethnographic interviews, observations, and video-based elicitation (asking teachers to view videos of their own practice and comment). Woods charts teachers' decision-making processes, based on an interaction between their beliefs, planning, and implementation of their teaching, and shows how these all loop back into their future teaching. In a similar type of study and the earliest of its kind, Johnson (1992) analyzed the beliefs and decisions made by preservice ESL teachers based on their student input and shows how these are cognitively organized. In his seminal book, Borg (2006) discusses strengths and limitations of research methods (self-report instruments, verbal commentaries, observation, and reflecting writing) used for research on teacher cognition. While teachers' mental lives are not observable, Borg argues for the importance of combining data collection strategies to triangulate findings. Multiple data can make tacit teacher thinking explicit and contextualize one's professional actions.

The second strand of research that has been influential has been that of language teachers studying their own classroom. Allwright and Bailey's (1991) book on classroom research for language teachers attempts to provide guidelines for teachers to conduct research in their own classrooms. Its aim is to provide tools for teachers to address immediate and practical issues that come up in their classrooms rather than actually testing different types of large-scale methods. One of the most popular forms of teacher research has certainly been action research, although the methods described in this volume span a range: from the naturalistic (observations, case studies, diaries) to ones that require more intervention (action research, elicitation), as well as those that are more quantitative (experimental, analytic observation frameworks). Allwright and Bailey (1991) provided guidelines for the examination of classroom interaction (e.g., error correction, student participation, teacher talk). They concluded that each of the areas of language learning and teaching need to be investigated as they emerge by teachers in their own settings, and by involving their learners (e.g., having students keep a language learner diary). The authors

synthesized their own approach to classroom research on/with language teachers as exploratory teaching, which has subsequently expanded into a research approach and methodology for teachers referred to as exploratory practice (Allwright and Lenzuen 1997). Exploratory practice is a process where language teachers attempt to understand what is happening in their classrooms through puzzling over their area of focus in a systematic fashion. Differently from action research, the focus of exploratory practice is on a teacher actually changing a practice as a result of the research conducted by the teacher in her classroom. Originating in Brazil (Allwright and Lenzuen 1997) it became a more popular form of teacher research across the world when it was integrated with the establishment of the Exploratory Practice Centre at Lancaster University in 2000.

The topic of Edge and Richards' (1993) edited volume is also classroom research but for the explicit purpose of teacher development. The authors in this volume also used a range of methods (e.g., experimental, naturalistic) but shared characteristics with the problem-solving orientation of action research. In Edge's (2001) book on action research for the (Teachers of English to Speakers of Other Languages) TESOL professional development series, he describes action research as an inquiry-based approach to one's teaching and practice that can be transformative at a personal, social, and political level. A number of books exist that are notable in the area of action research and language teaching, among those is one by Wallace (1998). Once again, all these monographs illustrate a range of methodologies that can be used by language teachers to study their own classrooms, from questionnaires to case studies, and from observation schemes to quasiexperimental studies (McDonough and McDonough 1997). The range of the scope of language teaching is also evident in these different books; that is, from the individual to the social, from the politically neutral to the overtly political.

---

## Work in Progress

As qualitative research has become more popular in understanding language teaching and teachers, ethnographic methods, in particular, have been increasingly employed for this purpose. This has also taken place due to the greater acknowledgment of the social and the political contexts of language teaching, which places more emphasis on the roles that language teachers take on beyond the classroom. Studies of language teachers in recent years often have taken an ethnographic approach toward language teaching with the understanding that it is shaped by and shaping the sociopolitical context surrounding teachers. For example, Skilton-Sylvester (2003) primarily used this methodology to understand how ESL teachers in the USA can be language policy makers in a context where students' native languages and cultures are undervalued. More recently, in her book-length ethnography, Creese (2005) described the roles of Turkish language specialists in mainstream classrooms and showed how they are marginalized in the classroom and in the schools although they serve as critical resources for their students.

Ethnographic methods, like other methodologies (e.g., case-study approach and narrative analysis), also highlight the importance of the local perspective as well as that of narrative and stories in understanding language teaching and teachers. In her study of four ESL teachers in Hong Kong, Tsui (2003) uses an ethnographic approach of the four teachers to provide a description of a range of expertise in second-language teaching. To develop the case studies, Tsui conducted classroom observations of the teachers where she took field notes and interviewed the teachers. In her interviews, she initially focused on their life histories and backgrounds and then progressively on issues that came up in their classroom teaching; particular attention was paid to how the teachers' professional development connected to what they did and how they thought of what they did in the classroom. Duff and Uchida (1997) also used an ethnographic case-study approach of four EFL teachers in Japan and looked at how the teachers saw themselves as cultural agents in the classroom and how these self-images interacted with their curriculum, classroom practices, student interactions, and larger institutional issues.

In what can be described as the narrative turn of language teacher research methods, much has been made of the importance of teachers' biographical experiences, from their own early childhood and schooling experiences to their professional learning experiences, and especially their influence on teachers' practice. Primarily through interviews of language teachers, studies using narrative analysis (Alleksaht-Snider 1996; Bailey and Nunan 1996; Freeman and Richards 1996; Galindo 1996) have shed light on this critical aspect of teacher development. Interestingly, some of these studies (Alleksaht-Snider 1996; Galindo 1996; Liu 1999) have used this approach to examine how bilingual and nonnative English-speaking language teachers relate their own, specific minoritized experiences to their own teaching. Like action research and exploratory practice, the narrative inquiry approach is one where teachers have studied their own narratives and those of their classrooms to reflect on and improve their teaching (Johnson and Golombek 2002). Currently, there has been increasing attention paid to teacher research. While action research and teacher research are similar regard to teachers as researchers, Borg (2013) notes that the latter is broader and more vigorous. Teacher research must be conducted by teachers in their own professional setting and offers evidence-based practice. The use of research can inform teachers of better pedagogical practice that leads to change of student learning and institutional policies. Another rationale is that the results of teacher research must be made public to disseminate knowledge beyond the context where it is generated.

---

## Problems and Difficulties

Two prominent difficulties in understanding and documenting language teaching and teachers are theoretical in nature: (1) how to understand and view language teacher knowledge and (2) how to conceptualize language teacher learning. Naturally, questions around the theoretical orientation of language teaching greatly influence the research methods that are promoted or challenged in language

teaching. A salient issue in that regard is how to describe or categorize language teachers' knowledge. As described earlier, Freeman and Johnson (1998) have called for a reconceptualization of language teacher education and for changing what constitutes the knowledge language teachers develop. In fact, the location and the categorization of teacher knowledge has recently been a subject of lively debate – from those who advocate that this knowledge develops in relation to individual teachers in interaction with their particular contexts (Edge 2001), and is actually “a process of reshaping existing knowledge, beliefs, and practices” (Johnson and Golombek 2003, p. 730) to those who have argued that it is of primary importance to consider the body of knowledge more statically (Yates and Muchisky 2003). What has also been equally problematic is that understanding the nature of language teaching can vary widely for the researched setting and context. For example, when Yates and Muchisky (2003) argued that second-language acquisition needs to be considered the main body of knowledge for language teachers, they failed to consider that a number of language teachers teach both language and content, especially in K-12 schools.

Another conceptual issue that also needs to be addressed is how to define teacher learning, as touched upon in earlier parts of the chapter (Freeman and Richards 1996). What is important to keep in mind is that recent work in cognition and learning have opened up possibilities of defining learning that is more external than internal (Putnam and Boroko 2000). Under this perspective, teacher learning is viewed primarily in the social context that it is being learnt and in the relationships that are being formed. This view locates teacher learning more on a social plane rather than an internal, cognitive plane although these are seen as related to each other. A sociocultural perspective is proposed by Johnson (2009) to recognize and explicate interconnections between the cognitive and social aspects involved in teacher learning. Particularly, research on teacher cognition shows the influence of teachers' prior learning on teaching and their practical knowledge, born out of their interactions with students and social worlds. This sociocultural view on professional development of teachers is both apprenticeship and appropriation. Disciplinary knowledge and practices would be adopted and reconstructed based upon the teachers' personal stances and local situations. Besides, teacher learning as situated indicates that professional development occurs in any context, including but not limited to teachers' classroom, networking, and cyberspace. England's edited book (2012) describes teaching and learning in online TESOL programs in response to the increasing trend of distance teacher preparation.

A major issue remains of whether there is currently a formalized research agenda around language teacher research. As far as the 1980s, scholars in language education pointed to the need to establish a research agenda for language teaching, especially as it relates to teacher education (Allwright 1983; Freeman 1989; Richards and Nunan 1990). A similar concern has been voiced by researchers in mainstream teacher education as well (Cochran-Smith and Zeichner 2005). Within this research agenda, a critical question is how to connect language teaching to student outcomes. The push for focusing on language teachers, their cycle of learning, and their work and lives as well as the movement of language teacher

research have been extremely useful endeavors; nevertheless, for many there is still a need to understand what can be viewed as generalizable in the research and how language teacher education can make use of these research findings. From this, connections need to be established to how and what students learn. This has become even more critical in the K-12 arena since schools are becoming increasingly accountable for students' achievement in the USA, the UK, and elsewhere, thus, looking for ways to increase the success of their linguistically and culturally diverse student body. Canagarajah (2005) and several authors in his edited volume showed that due to the growing global and local pressures, many face to learn English, this has become a concern for governments and citizens all over the world and it is international in scope. Importantly, Johnson (2009) argues that teaching practices and learning outcomes should not be regarded as causality, but the *relationship of influence*. Research questions can be framed as how the growth of teacher knowledge influences teaching, and how that teaching influences students' learning.

---

## Future Directions

From the accountability perspective, there has been more of a push to connect how language teachers learn to how they eventually teach, and in turn, how to connect this to student outcomes; consequently, teacher education programs have increasingly been a focus of research in language teaching and will continue to be so. Much of the research methodology around studies of these programs has been naturalistic or qualitative to better understand the relationship of influence between teaching and learning. However, due also to the increasing demand/need for accountability of TESOL training programs and to the consideration of how they are related to student outcomes, it will be important to use mixed methods in understanding the process and outcomes of these programs. Riazi and Candlin (2014) noted that the mixed-methods enables researchers to collect and analyze data in a more comprehensive manner and address research questions that cannot be fully investigated with a single approach. Three out of the five articles in the 2012 *TESOL Quarterly* special issue on novice professionals were mixed-methods to examine the gap between teacher preparation and the first years teaching. The responses collected from the survey were used to corroborate the interview findings, which identified how professional development activities, support systems, and teaching contexts could enhance or inhibit teacher efficacy. Mixed-methods have been also commonly used to study bilingual education programs (e.g., Minaya-Rowe 2002) and immersion teacher education programs (e.g., Erben 2004). This trend is also evident in countries other than the ones that have traditionally been the focus of much of the research (such as the USA and the UK), as mentioned earlier.

Another prominent direction of language teacher research has been in understanding who language teachers are, their identities, and their roles. Within this, the political, moral, and racial dimensions of language teaching have been studied (Cheung et al. 2015; Varghese et al. 2005). Along with the ethnographic methods that have been used to study language teaching and teachers in this way, a

poststructural lens using a discursive approach (e.g., Creese 2005; Johnston 1997), in particular, has examined how teachers take up particular ideologies or discourses. In his interview study of Polish EFL teachers, Johnston used Bakhtin's concept of heteroglossia to show that the teachers use specific discourses to talk about themselves as not having a purposeful and linear career.

Since language teachers, language teaching, and language teacher education have only recently been recognized as central areas of research in applied linguistics, debates around some of the theoretical questions pertaining to this area of research will continue, as will the use of the different methodologies that have been used to study this area. At the same time, as with other areas of educational research, the forces of globalization and of accountability will inevitably continue to influence the research methodologies used to understand the following critical questions: how language teachers learn what they do, why language teachers do what they do, who language teachers are, and how what they do and who they are shape students' experiences and outcomes. On one hand, an increase in experimental studies may be an outcome of the accountability movement; on the other hand, the importance of understanding and taking into account the local perspective in language studies and globalization may lead to the promotion of more studies that are bottom-up and critical in understanding language teaching and teachers, foregrounding methodologies such as critical ethnographies and those using a poststructural lens.

---

## Cross-References

- ▶ [Discourse Analysis in Educational Research](#)
- ▶ [Ethnography and Language Education](#)
- ▶ [Second Language Acquisition Research Methods](#)

---

## Related Articles in the Encyclopedia of Language and Education

- Ofelia García: [Multilingual Language Awareness and Teacher Education](#). In Volume: Language Awareness and Multilingualism
- Oleg Tarnopolsky: [Nonnative Speaking Teachers of English as a Foreign Language](#). In Volume: Second and Foreign Language Education

---

## References

- Allexsaht-Snider, M. (1996). Windows into diverse worlds: The telling and sharing of teachers' life histories. *Education and Urban Society*, 29, 103–119.
- Allwright, D. (1983). Classroom-centered research on language teaching and learning: A brief historical overview. *TESOL Quarterly*, 17, 191–204.
- Allwright, D. B., & Bailey, K. M. (1991). *Focus on the language classroom: An introduction to classroom research for language teachers*. Cambridge: Cambridge University Press.

- Allwright, D. B., & Lenzuen, R. (1997). Exploratory practice: Work at the cultural ingles, Rio de Janeiro, Brazil. *Language Teaching Research*, 1, 73–79.
- Bailey, K. M. (1996). The best laid plans: Teachers' in-class decisions to depart from their lesson plans. In K. M. Bailey & D. Nunan (Eds.), *Voices from the language classroom: Qualitative research in second language education* (pp. 15–40). Cambridge: Cambridge University Press.
- Bailey, K. M., & Nunan, D. (Eds.). (1996). *Voices from the language classroom: Qualitative research in second language education*. Cambridge: Cambridge University Press.
- Barnard, R., & Burns, A. (Eds.). (2012). *Researching language teacher cognition and practice*. Bristol: Multilingual Matters.
- Borg, S. (2006). *Teacher cognition and language education: Research and practice*. London: Continuum.
- Borg, S. (2013). *Teacher research in language teaching: A critical analysis*. Cambridge: Cambridge University Press.
- Canagarajah, A. S. (Ed.). (2005). *Reclaiming the local in language policy and practice*. Mahwah: Lawrence Erlbaum.
- Chaudron, C. (1988). *Second language classrooms: Research on teaching and learning*. Cambridge: Cambridge University Press.
- Cheung, Y. L., Said, S. B., & Park, L. (Eds.). (2015). *Advances and current trends in language teacher identity research*. Abingdon, Oxon: Routledge.
- Cochran-Smith, M., & Zeichner, K. M. (Eds.). (2005). *Studying teacher education: The report of the AERA panel on research and teacher education*. Mahwah: Lawrence Erlbaum.
- Creese, A. (2005). Teacher collaboration and talk in multilingual classrooms. Clevedon: Multilingual Matters.
- Duff, P. A., & Uchida, Y. (1997). The negotiation of teachers' sociocultural identities and practices in postsecondary EFL classrooms. *TESOL Quarterly*, 31, 451–486.
- Edge, J. (Ed.). (2001). *Action research*. Alexandria: Teachers of English to Speakers of Other Languages Inc.
- Edge, J., & Richards, K. (Eds.). (1993). *Teachers develop teachers research: Papers on classroom research and teacher development*. Oxford: Heinemann International.
- England, L. (Ed.). (2012). *Online language teacher education: TESOL perspectives*. Abingdon: Routledge.
- Erben, T. (2004). Emerging research and practices in immersion teacher education. *Annual Review of Applied Linguistics*, 24, 320–338.
- Freeman, D. (1989). Teacher training, development, and decision making model: A model of teaching and related strategies for language teacher education. *TESOL Quarterly*, 23, 27–45.
- Freeman, D. (1998). *Doing teacher research: From inquiry to understanding*. Boston: Heinle & Heinle Publishers.
- Freeman, D., & Richards, J. C. (Eds.). (1996). *Teacher learning in language teaching*. Cambridge: Cambridge University Press.
- Freeman, D., & Johnson, K. E. (1998). Reconceptualizing the knowledge base of language teacher education. *TESOL Quarterly*, 32, 397–417.
- Fröhlich, M., Spada, N., & Allen, P. (1985). Differences in the communicative orientation of L2 classrooms. *TESOL Quarterly*, 19, 27–56.
- Galindo, R. (1996). Reframing the past in the present: Chicana teacher role identity as a bridging identity. *Education and Urban Society*, 29, 85–102.
- Johnson, K. E. (1992). Learning to teach: Instructional actions and decisions of preservice ESL teachers. *TESOL Quarterly*, 26, 507–535.
- Johnson, K. E. (1996). The vision versus the reality: The tensions of the TESOL practicum. In D. R. Freeman & J. C. Richards (Eds.), *Teacher learning in language teaching* (pp. 30–49). Cambridge: Cambridge University Press.
- Johnson, K. E. (2009). *Second language teacher education*. New York: Routledge.
- Johnson, K. E., & Golombek, P. R. (Eds.). (2002). *Teachers' narrative inquiry as professional development*. Cambridge: Cambridge University Press.



- Johnson, K. E., & Golombek, P. R. (2003). "Seeing" teacher learning. *TESOL Quarterly*, 37, 729–738.
- Johnston, B. (1997). Do EFL teachers have careers? *TESOL Quarterly*, 31, 681–712.
- Liu, J. (1999). Nonnative English-speaking professionals in TESOL. *TESOL Quarterly*, 33, 85–102.
- McDonough, J., & McDonough, S. (1997). *Research methods for English language teachers*. London: Arnold.
- Minaya-Rowe, L. (Ed.). (2002). *Teacher training and effective pedagogy in the context of student diversity*. Greenwich: Information Age.
- Nunan, D. (1988). *The learner-centered curriculum: A study in second language teaching*. Cambridge: Cambridge University Press.
- Pennington, M. C. (1996). When input becomes intake: Tracing the sources of teachers "attitude change". In D. R. Freeman & J. C. Richards (Eds.), *Teacher learning in language teaching* (pp. 320–348). Cambridge: Cambridge University Press.
- Politzer, R. L. (1970). Some reflections on "good" and "bad" language teaching behaviors. *Language Learning*, 20, 31–43.
- Putnam, R. T., & Borko, H. (2000). What do new views of knowledge and thinking have to say about research on teacher learning? *Educational Researcher*, 29, 4–16.
- Riazi, A. M., & Candlin, C. N. (2014). Mixed-methods research in language teaching and learning: Opportunities, issues and challenges. *Language Teaching*, 47, 135–173.
- Richards, J. C. (1990). The dilemma of teacher education in second language teaching. In J. C. Richards & D. Nunan (Eds.), *Second language teacher education* (pp. 3–16). Cambridge: Cambridge University Press.
- Richards, J. C., & Nunan, D. (Eds.). (1990). *Second language teacher education*. Cambridge: Cambridge University Press.
- Skilton-Sylvester, E. (2003). Legal discourses and decisions, teacher policymaking and the multilingual classroom: Constraining and supporting Khmer/English biliteracy in the United States. *International Journal of Bilingual Education and Bilingualism*, 6(3), 168–184.
- Smith, P. D. (1970). *A comparison of the cognitive and audiolingual approaches to foreign language instruction: The Pennsylvania foreign language project*. Philadelphia: Center for Curriculum Development.
- Tsui, A. B. M. (2003). *Understanding expertise in teaching: Case studies of second language teachers*. Cambridge: Cambridge University Press.
- van Lier, L. (1986). Conflicting voices: Language, classrooms, and bilingual education. In K. Bailey & D. Nunan (Eds.), *Voices from the language classroom: Qualitative research in second language education* (pp. 363–387). Cambridge: Cambridge University Press.
- van Lier, L. (1988). *The classroom and the language learner: Ethnography and second language classrooms*. London: Longman.
- Varghese, M., Morgan, B., Johnston, B., & Johnson, K. (2005). Theorizing language teacher identity: Three perspectives and beyond. *Journal of Language, Identity and Education*, 4, 21–44.
- Wallace, M. (1998). *Action research for language teachers*. Cambridge: Cambridge University Press.
- Woods, D. (1998). *Teacher cognition in language teaching*. Cambridge: Cambridge University Press.
- Yates, R., & Muchisky, D. (2003). On reconceptualizing teacher education. *TESOL Quarterly*, 37, 135–146.

---

## **Part IV**

# **Language, Interaction, and Education**

---

# Microethnography in the Classroom

Pedro M. Garcez

---

## Abstract

Ethnographic microanalysis of interaction, or microethnography, describes how interaction is socially and culturally organized in particular situational settings, such as classrooms, where key episodes of consequence for people's lives may be taking place in the course of everyday routines. Microethnographers work with audiovisual records of naturally occurring social encounters to investigate in detail what interactants do in real time. Microethnography offers a methodology for the investigation of face-to-face interaction and a particular point of view on language use in multiparty arrangements in complex modern societies to understand what constitutes social and communicative competence and to connect situated interactional episodes to societal issues such as social opportunity and cultural politics. With digital audio and video technology now widely available, the collection and handling of video records of interaction have been facilitated, yet microethnographic research remains laborious as it requires careful and continued revisitation of records, identification of major constituent parts and the aspects of organization within them, analysis of the actions of individuals, and finally comparison of instances of the phenomenon of interest across a research corpus. Microethnographers have provided understandings of inequality as embodied in social interaction in educational encounters, and their methodological contributions have also been disseminated widely, among others, as a way to comprehend how literacy practices are enacted in classrooms. In addition, their research has produced pedagogical implications in bridging cultural discontinuities in classrooms while exposing the benefits of variety and flexibility in the social organization of classroom talk-in-interaction as a resource in classroom instruction.

---

P.M. Garcez (✉)

Instituto de Letras/Linguistics, Federal University of Rio Grande do Sul (UFRGS) and Brazilian National Council for Scientific and Technological Development (CNPq), Porto Alegre, RS, Brazil  
e-mail: [pmgarcez@pq.cnpq.br](mailto:pmgarcez@pq.cnpq.br)

---

**Keywords**

Classroom interaction • Communicative competence • Context • Ethnography • Inequality • Interaction • Listenership • Literacy • Microethnography • Talk-in-interaction

**Contents**

Introduction .....	436
Early Developments .....	436
Major Contributions .....	437
Work in Progress .....	441
Problems and Difficulties .....	443
Future Directions .....	445
Cross-References .....	445
Related Articles in the Encyclopedia of Language and Education .....	446
References .....	446

---

**Introduction**

Microethnography is concerned with the local and situated ecology among participants in face-to-face interactional engagements constituting societal and historical experience. Microethnographers examine observable communicative behaviors to understand and discuss major social issues. *Ethnographic microanalysis of interaction*, as microethnography is also known, describes how interaction is socially and culturally organized in particular situational settings, such as classrooms, where key episodes of consequence for people's life chances may be taking place against the murky backdrop of everyday routine. Microethnographers typically work with audiovisual machine recordings of naturally occurring social encounters to investigate in minute detail what interactants do in real time as they co-construct talk-in-interaction in everyday life. As such, microethnography offers a methodology for the investigation of face-to-face interaction and a particular point of view on language use in multiparty arrangements in complex modern societies (Erickson 1992, 2004; McDermott et al. 1978; McDermott and Raley 2011). This view stresses that the social and cultural organization of human communicative action (Erickson and Shultz 1982) involves conversationalists contained in physical bodies, occupying space in simultaneously constraining and enabling social situations, who must reflexively make sense of each other's actions as they act through sets of signaling and interpretive resources that may not be shared completely.

---

**Early Developments**

Microethnography has intellectual origins in research traditions that converge in their interest in the organization of human social interaction. Among early influences is *context analysis*, which pioneered the use of audiovisual records as primary

sources of research data to study communicative interaction (see Kendon 1990). Their work shaped microethnography's commitment to the examination of nonvocal and nonverbal behavior as well as the unspoken activities of listenership in the study of face-to-face interaction (e.g., Erickson and Shultz 1977/1981; McDermott and Gospodinoff 1979/1981; Streeck 1983; see also Erickson in Johnson and Amador 2011). A second root is *the ethnography of communication*, from which microethnography inherited a linguistic anthropological concern with culturally appropriate forms of talk and with variation in the function-form relationship in language use within and across speech communities (e.g., Michaels 1981; Shultz et al. 1982). Goffman's studies on the "situational" (Goffman 1981, p. 84) character of *the interactional order* are a third source. Based on the view that social interaction occurs within constraints of what participants agree is the situation they are in, microethnographies demonstrate empirically the subtle ways in which participants (re-)arrange their alignments toward one another and (re-)frame their communicative actions accordingly.

Ethnographic microanalysis of interaction has also profited from early and contemporary studies in *ethnomethodology* and *conversation analysis* about the real-time sequential organization of conversation. Given the shared methodological stance of privileging the participants' recognizable sense-making perspectives in the analysis of talk and social interaction, the conversation analytic and microethnographic perspectives often display close affinity (cf. Goodwin 1981; Hellermann 2006; Mehan 1979).

Similar influences have also marked research in *interactional sociolinguistics* (Gumperz 1982; Jaspers 2012), with which microethnography shares most concerns and assumptions. Considerable overlap and cross-fertilization has existed between the approaches since the procedures developed by microethnographers paved the way for contemporary multimodal analysis of interaction (see Gumperz 1982, p. 134). In addition, common linguistic anthropological roots connect interactional sociolinguists and microethnographers in their efforts to produce natural histories of key interactional encounters.

Indeed McDermott and Raley (2011) "call on (and impose) the term" *natural history* to describe the approach within what they refer to as "a small, but alternative visual tradition that has developed on the edges of mainstream social sciences . . . for the last half-century" (p. 373). Drawing "heavily from ethnography, interaction and conversation analysis, sociolinguistics, and kinesics, . . . a *natural history analysis examines organisms and environments interwoven in real time in situations consequential to their participants and beyond*" (p. 373, original emphasis).

---

## Major Contributions

Initial microethnographic work began in the 1970s through an interest in examining processes of mutual social influence among face-to-face interactants, particularly in terms of how participants create context and *make sense* during their activities together in educational environments. This early work, led by Frederick Erickson

and Ray McDermott, carried the hallmarks of the microethnographic contribution to the study of language and social interaction in educational settings. Among its features are, first, methodical attention to nonvocal and listener behaviors *simultaneously* with the (traditionally studied) verbal behaviors of speakers, including the noting of interactional rhythm and cadence, and, second, a thematic focus on mutual, simultaneous, and successive influences among participants in interaction, the construction of labile situated social identities, and the management of culture difference.

Mehan (1998) identified four major themes as the highlights of ethnographic microanalysis of interaction in education. First, microethnographies have shown that “significant cognitive structures, such as intelligence, ability and disability, such social structures as identities and steps in educational career ladders are socially constructed in locally organized social situations” (p. 248), with classrooms as one key setting for such work. Second, microethnographers have both produced a methodology and helped underscore the “context-specific nature of human behavior” (p. 247), of which the educational community and public political discourse need constant reminding lest judgments are made on the basis of ungrounded overextension of theoretical or personal presuppositions that often expose the behavior of participants in classroom interaction as incompetent, disorganized, senseless, or inferior. A third line of work contrasted the social organization of classroom lessons with that of the children’s home, especially of low-income and ethnic minority backgrounds, which has produced the “cultural discontinuity account of school difficulty” (p. 249) for children who may need to make major adjustments to the interactional etiquette they bring from home if they are to be seen as socially competent in the classroom, and thus deserving of access to the social opportunities made available by the educational system. A fourth contribution has been the empirical evidence provided for the characterization of the social nature of human learning, which has in turn supported the view that learning is constructed through guided assistance.

In a seminal contribution, Erickson and Shultz (1977/1981) asked the crucial microethnographic question: “when is a context?” Drawing attention to aspects of interactional behavior whose meaning may be redundant across the different communicative channels, they showed that this redundancy – easily mistaken for interactional noise – is in fact essential for face-to-face interactants to be able to gauge what and “when” the context is and act in socially appropriate ways. Moreover, appropriate displays of this ability can be a determining factor in judgments made about social competence, an issue of paramount importance in educational encounters.

In a series of classroom studies investigating how teacher and minority children learning to read organized their activities and time together, McDermott (e.g., McDermott et al. 1978) built a solid case for the microethnographic notion that “people constitute environments for each other” (McDermott 1976, p. 27; cited in Erickson and Shultz 1982, p. 7; see McDermott and Raley 2011, p. 373). In the situational ecologies where discourse is produced in face-to-face interaction, it is through the monitoring of the effects of her/his performance on the listener that the

speaker can see how effectively she/he is interacting and where she/he must change according to the continuously emerging context.

McDermott and Gospodinoff (1979/1981) puzzled over the conflicting interaction between a white teacher and her Puerto Rican kindergarten student. The boy conspicuously flouted culture-specific social etiquette norms for address, bodily touch, and interactional space in the classroom until the teacher joined him in creating an incident that disrupted her work session with the lowest level reading group. Combining careful scrutiny of the participants' verbal and nonverbal behaviors with attention to the micropolitics of the interaction, McDermott and Gospodinoff showed that student and teacher engaged in *border work*, that is, they were adding a sociopolitical layer onto cultural identity markers. McDermott and Gospodinoff posited that participants often exploit cultural differences – simple *boundaries* of identity which can be crossed over and do not intrinsically constitute impediments to optimal communication, such as norms for bodily touch in interaction – as convenient tools to deal with immediate interactional pressures or to communicate conflicting interests over resources. In the short run, the classroom incident was “to everyone’s advantage” (1981, p. 224). The boy secured the teacher’s attention, while “the teacher and the children in the bottom group [got] a brief rest from their intense organizational negotiations” (p. 224). In the long run, however, occurrences of interactional conflict due to the micropolitical exploitation of small cultural differences sediment what would otherwise be passable *boundaries* of identity into insurmountable interactional *borders*, with lifetime consequences for those like the student mentioned above, as these borders serve as cultural trenches for societal struggle among individuals in competing identity groups.

Erickson and Shultz’ (1982) detailed microanalysis of interethnic counseling interviews in junior colleges is a classic microethnographic investigation of participation structure, interactional rhythm, and listening behavior in relation to speaking. It shows how the local interdigitation of concerted action – the interlocking of interactional gears – enters into the achievement of critical gatekeeping decisions that are consequential in terms of access to social opportunity. Highly significant to the study of cross-cultural communication is Erickson and Shultz’ (1982) empirical finding that, despite the clear relation between culture difference and interactional trouble, when culturally dissimilar student and counselor managed to activate particular “attributes of shared status” (p. 35), or *comembership* (e.g., common interest in Catholic high school sports), their interactions were observed to be significantly less uncomfortable. In addition to providing evidence of the dynamically emergent nature of context in everyday interaction, Erickson and Shultz (1982) brought forth the social-scientific relevance of examining the real-time organization of verbal and nonverbal activities of speakers and listeners. They discuss these issues in terms of *reciprocity* (i.e., “the interdependence of actions taken successively across moments in time,” p. 71) and *complementarity* (i.e., “interdependence of actions taken simultaneously in the same moment,” p. 71), thus emphasizing the microethnographic view that face-to-face interaction is built on actions in physical time and space, rather than simply on the exchange of meaningful utterances.

A concern with real-time, locally appropriate ways of making sense in embodied interaction was also the focus of Shultz and Florio's (1979) work. They showed how a teacher's routine verbal and nonverbal behaviors – outside her own or the students' conscious awareness – were critical to the organization of classroom life. Learning how to make sense of these contextualization cues (Gumperz 1982), they showed, enables students to navigate across the classroom environment appropriately and ultimately reflects on their perceived interactional competence.

Streeck (1983) examined linguistic and kinesic features composing the ecology of communicative processes in “peer teaching” events in a group of five minority schoolchildren. He described the procedures by which the children organize their interaction frame by frame to achieve and sustain a consensus of what their activity is and to seal off their interactional space from the surrounding world, a process in which they “thereby contextualize the linguistic process of giving and receiving instructions” (p. 2).

Shultz et al. (1982) investigated the contrastive social organization of different participation structures for conversation that Italian-American students encountered at home and at school. While some social participation structures found in the classroom resemble the structure and timing for appropriateness of those in the children's homes, mismatches were observed. Participation structures in which the speaker-audience relationships allow for the simultaneous occurrence of more than one *floor* (i.e., access to a turn at speaking that is attended to by others) were routinely found at home. However, when students produced them at school, the same participation structures constituted reason for reproach. This analysis suggested that floor, as an aspect of the ecology of interaction, is not necessarily a unitary phenomenon. In addition, it showed how small children may find it difficult to know what constitutes appropriate communicative behavior at school.

A number of microethnographic studies focused closely on (mis)matches between home and school cultural norms for communicative behavior. Among them, Au (1980) and Au and Mason (1983) argued that cultural congruence in the rules governing participation in classroom activities may facilitate academic learning. These studies showed how native Hawaiian children were more comfortable in a classroom ecology where participation structures similar to the ones they were familiar with at home were used in reading lessons, resulting in improved reading scores in the long run. Michaels (1981) analyzed “sharing time” in an ethnically mixed first-grade classroom and argued that the observed mismatches in teacher/student culturally based discourse strategies and prosodic conventions for giving narrative accounts have potentially adverse effects on the minority students' access to key literacy-related experiences.

In sum, microethnographers have provided, according to Mehan (1998), “a new paradigm for understating inequality” (p. 254) as they “removed social structures from a disembodied external world and relocated them in social interaction” while they also “took cognitive structures out of the mind and related them in interaction” (p. 254). Microethnography's methodological contributions have also been disseminated widely, even if acknowledgement of its early emphasis on what more recently has been referred to as *multimodality* is sometimes lacking. In addition,



microethnography had pedagogical implications in that it called attention to the need to bridge cultural discontinuities in the classroom while exposing the benefits of variety and flexibility in the social organization of classroom talk-in-interaction as a resource in classroom instruction.

---

## Work in Progress

Microethnographic studies are deeply concerned with the elusive nature of context in social interaction (Erickson and Shultz 1977/1981) and the role it may play in the interpretation of utterances and other communicative behavior. Microethnographers have also provided useful heuristics for the analysis of context in face-to-face interaction (Erickson 1992, 2004; Erickson and Shultz 1977/1981; McDermott et al. 1978). There has been a significant contribution to unravel what constitutes social and communicative competence and to connect interactional processes to societal issues such as social opportunity and cultural politics.

The main empirical concerns of early microethnographic work – the relationship of listening behavior in relation to speaking, the nature of contextualization processes in interaction, the construction of situated social identities, and the lability in the foregrounding of aspects of social identity in everyday face-to-face interaction – continued to be the focus of later work (Erickson 1996; Fiksdal 1990; O'Connor and Michaels 1996). In addition, initial microethnographic methods and points of view have been taken in new directions, some of them toward the understanding of how reading and writing are constructed as integrally social processes.

One such direction is research on *the language and culture of classrooms* conducted by the Santa Barbara Classroom Discourse Group, which congregates researchers with special interest in issues of classroom interaction and reading and writing instruction, learning, and practice (see contributions in Green and Dixon 1994; Jennings and Green 1999). An example of such focus can be seen in Castanheira et al.'s (2001) interest in “what counted as literacy” in the practices of teacher and students across five classes in a vocationally oriented secondary school in Australia. Through analysis of what counted as text, as literate practices, and as participation in each class, they illustrated the research approach they term “interactional ethnography” and provided relevant theoretical discussion of the relationships between theory and method. “The interactional ethnographer,” they argued, “must look at what is constructed in and through the moment-by-moment interactions among members of a social group; how members negotiate events through these interactions; and the ways in which knowledge and texts generated in one event become linked to, and thus a resource for, members’ actions in subsequent events” (p. 357). As Green et al. (2007) explain, “this approach involves two interrelated angles of analysis – one focusing on the discourse(s), social actions, accomplishments and outcomes at the level of the collective, and one focusing on individuals within the collective, how they take up (or not) what is constructed at the collective level, and how they use these material resources in subsequent events” (p. 118). Thus building on previous microethnographic work, they emphasize the

connections between social action and the production of artifacts as well as the links among various episodes in the interactional history of a group of people such as a class of students.

Similar concerns are present in the work of David Bloome and his associates on *literacy practices*. Bloome and Egan-Robertson (1993), for example, microanalyzed a first-grade classroom reading event to show the moment-by-moment emergence of intertextuality as a social construction that can be “located in the material of people’s social interaction” (p. 330). In demonstrating this, moreover, the authors interpreted an event in which two students resisted full participation in a reading lesson and seemed off task, when in fact they were making relevant intertextual links, though using intertextuality differently from the rest of the class to “define themselves as readers outside the definition of being students” (p. 330).

Bloome et al. (2005) examined classroom literacy events in the light of increasingly explicit concerns with gender, race, identity, and power relations within and beyond schools. In the tradition of microethnographers, they keep methodological, theoretical, and epistemological issues well united while attending to broad social and cultural processes, always stressing the conception of people as complex, multi-identity actors working together with the tools given by culture, language, social, and economic capital to create new meanings, social relationships, and possibilities within the affordances of interaction in all of its complexity, ambiguity, and indeterminacy.

More recently, Bloome et al. (2009) have looked at “*how* time is socially constructed” and shapes “learning opportunities in a ninth-grade language arts classroom” (p. 313). They develop “grounded theoretical constructs” to support future discussions about the nature and use of time in classrooms, and show that “the processes of socially constructing intercontextuality and building collective memories are two of the processes employed by teachers and students in structuring and organizing time” (p. 331).

Microethnography has also been introduced to new academic environments, where it is shedding light on issues of social identities, schooling, and opportunities to learn crucial literacy skills. By examining how some students were able to participate in classroom literacy events more centrally than others, Jung (2009) showed how students and teacher in a first-grade classroom in a semiliterate multilingual rural community in Brazil reproduce and recreate complex social identities that may be evident in settings throughout the local community. The resulting view shows that a same classroom literacy event may afford different opportunities to participate and learn the literacy practices that are hard to come by outside the school environment. Thus, a “good learner” is expected to emulate the practices associated with the female, Catholic, German-ethnic, and non-German-speaking semiliterate, and students unwilling to participate as such may be challenged.

McDermott and Raley (2011) highlight ingenious agency in a classroom by showing how a young girl who can hardly read at all is able to recruit and arrange just the right people – at the right time and doing the right things for her – to pull off a public display of her success at reading a list of names all by herself. In this

kindergarten classroom actively organized for displays of who can or cannot read independently, the supporting work by two boys in the scene, one of them reading backwards and through paper, is easy to miss. The ability to read is shown to be “the systematic product of real people pointing at, gathering around, interrupting and tugging on other real people and real objects in real time – sometimes with and sometimes without regard for who really can and who really cannot read” (pp. 386–387).

The early developments of microethnographic work focusing on cross-social and cross-cultural encounters in classrooms continue to prove valuable to illuminate analyses of issues brought about by contemporary developments such as transnational flows of people that materialize in displays and struggles around cultural citizenship in classrooms. García-Sánchez (2013), for example, has looked at how Moroccan immigrant children’s ethnolinguistic identities get constructed in their daily classroom interactions in a rural town in Spain. By “analyzing the indexical links between locally-situated acts of cultural citizenship and large scale processes of cultural politics of recognition and belonging in Spain” (p. 491), she documents how teachers orient to a sense of national citizenship predicated on homogeneity while the immigrant manage “to carve an interactional space to counter these rigid structures of belonging, as well as to assert alternative forms of cultural citizenship by claiming belonging to multiple linguistic and national collectivities” (p. 492).

---

## Problems and Difficulties

The insights and contributions of ethnographic microanalysis of interaction to the fields of education, cross-cultural communication, and the organization of face-to-face interaction have long been recognized, and microethnography remains a productive research approach. Yet the relatively limited additional microanalytic work with “the same sort of intensive videotape analysis that was the hallmark of the early research” (Shultz, personal communication) bespeaks of difficulties in its wider application as a research method. As Erickson (1992) pointed out, ethnographic microanalysis of interaction is labor intensive and “should not be used unless it is really needed” (p. 204). It is especially appropriate to investigate social interaction in face-to-face events that are “rare or fleeting in duration or when the distinctive shape and character of such events unfolds moment by moment, during which it is important to have accurate information on the speech and nonverbal behavior of particular participants in the scene” (pp. 204–205).

With digital audio and video technology now widely available, the collection and handling of video records of interaction have been greatly facilitated, but analysts must still become familiar with equipment and procedures which often impose demands of their own. Yet the benefits of microethnographic research can only be fully achieved through careful and continued revisitation of these records, identifying its major constituent parts and the aspects of organization within them, then focusing on the actions of individuals, and finally comparing instances of the

phenomenon of interest across the research corpus. Still this process of “considering whole events, . . . analytically decomposing them into smaller fragments, and then . . . recomposing them into wholes” (Erickson 1992, p. 217) demands great attention and time, inevitably limiting the amount of data that can be processed (thus the case-study nature of microethnographies). Nonetheless, it remains a distinctive strength of microethnography that it can produce deep analyses of phenomena which may be impossible to perceive in real-time observation and which may be too heavily laden with common-sense perceptions for participant observers to even notice (McDermott and Raley 2011). It thus offers tools “to identify subtle nuances of meaning . . . that may be shifting over the course of activity that takes place” and whose verification may enable us to see “*experience in practice*” more clearly (Erickson 1992, p. 205). Bringing a spate of life up close for minute inspection – so that precisely *how* it came about can be understood and described – makes it available for redress or emulation, as in the case of episodes of engagement in a rich intellectual environment giving rise to a learning community. In such cases, documenting skillful educational practitioners and putting their expertise into practice formulate what desirable teaching is all about.

The laborious quality of microethnography makes it especially apt for examining fleeting social processes and establishing their connection to more encompassing processes that ultimately constitute society and history. It is in this light that microethnographers refer to the inadequacy of “micro” as the label for their research work, which can in fact be quite macro (cf. Bloome and Egan-Robertson 1993, p. 331; Bloome et al. 2005; Erickson 1992, pp. 222–223). Since the microethnographic approach to data analysis is largely inductive, a priori concerns with macrostructural formations do not drive the analytic process (cf. Erickson 1992; Gumperz 1982). It is only when substantial emic evidence warrants their treatment, in later stages of the research process, that they become analytically foregrounded. As a result, microethnographers may be seen as ignoring the wider social contexts that shape the interactants’ displayed stances, in what Mehan (1998) refers to as “radical contextualism” (p. 259). However, in showing the subtle ecologies that participants create in face-to-face interaction, as social actors who are both reproducing and altering their “macro” social structures in situated talk-in-interaction, microethnographies in fact describe the co-construction, in and through discourse, of joint social realities which are intimately connected to wider societal processes such as, for example, interethnic struggle and social opportunity (e.g., Erickson and Shultz 1982; García-Sánchez 2013).

Erickson (2004) is directly interested in bridging the gap between microethnographic analytic perspectives and wider concerns which have more typically been addressed by social theorists who favor the view “that the conduct of talk in local social interaction is profoundly influenced by processes that occur beyond the temporal and spatial horizon of the immediate occasion of interaction” (p. viii). By situating minute analyses of interactional episodes (such as a humdrum academic counseling interview in a community college in 1970) within large-scale social phenomena made evident with the benefit of historical hindsight (such as resistance

to the Vietnam War), he is able to speak directly to major works in European social theory, which, while conceptually persuasive, are often thin on empirical evidence. He shows how what happens in the here-and-now of people living their lives in particular situations sediments in larger social phenomena observable with the passing of time and across different settings.

Bloome et al. (2005) also address the connections between local interactional issues and the wider social contexts that shape the interactants' displayed stances. While emphasizing metaresearch issues [e.g., "microethnographic cultural description and the dilemmas of structure and substance" in the analysis of classroom literacy events (pp. 55–56), or the relationship of microethnographic discourse analysis studies of classroom language and literacy events to other types of research and lines of inquiry" (p. 233)], they provide an especially telling analysis of two elementary education classrooms in the USA to show "different formulations of how literacy is implicated in power relations and, more specifically, how literacy events may be implicated in transforming power relations" (p. 220).

---

## Future Directions

Contemporary social theory has restored the notion that the situated communicative activities of flesh-and-blood interactants are critical to the constitution of society and historical experience. Microethnography stands as a discourse-and-interaction analytic research method that can in fact support the empirical characterization of what people do when they interact face to face in everyday life. With video now an accessible data collection resource and with the increasing realization that verbal/speaker discourse is but one aspect of what needs to be attended to for the comprehensive understanding of the embodied and situated activities of human communicative behavior, microethnography keeps offering significant contributions to the description of societal-historical processes constituted in the situated reflexive practice of social agents. Following the criticisms of their radical contextualism that may jeopardize its capacity to illuminate what is going on in educational encounters such as those that happen in classrooms, microethnographers' head-on attempt to improve the field's grasp of the complex "interconnections between social structure, culture and social interaction" while also attending to the need "to reconcile the conflictual and consensual dimensions of learning" (Mehan 1998, p. 264) is proof of the vitality of microethnographic analysis of interaction in educational settings.

---

## Cross-References

- ▶ [Conversation Analytic Approaches to Language and Education](#)
- ▶ [Ethnography and Language Education](#)
- ▶ [Linguistic Ethnography](#)

## Related Articles in the Encyclopedia of Language and Education

Numa Markee and Silvia Kunitz: [Understanding the Fuzzy Borders of Context in Conversation Analysis and Ethnography](#). In Volume: Discourse and Education

Patricia Duff: [Language Socialization, Participation and Identity: Ethnographic Approaches](#). In Volume: Discourse and Education

---

## References

- Au, K. H. (1980). Participation structures in a reading lesson with Hawaiian children: Analysis of a culturally appropriate instructional event. *Anthropology and Education Quarterly*, 11(2), 91–115.
- Au, K. H., & Mason, J. M. (1983). Cultural congruence in classroom participation structures: Achieving a balance of rights. *Discourse Processes*, 6(2), 145–167.
- Bloome, D., & Egan-Robertson, A. (1993). The social construction of intertextuality in classroom reading and writing lessons. *Reading Research Quarterly*, 28(4), 303–334.
- Bloome, D., Carter, S., Christian, B., Otto, S., & Shuart-Faris, N. (2005). *Discourse analysis and the study of classroom language and literacy events: A microethnographic approach*. Mahwah: Erlbaum.
- Bloome, D., Beierle, M., Grigorenko, M., & Goldman, S. (2009). Learning over time: Uses of intercontextuality, collective memories, and classroom chronotopes in the construction of learning opportunities in a ninth grade language arts classroom. *Language and Education*, 23(4), 313–334.
- Castanheira, M., Crawford, T., Dixon, C., & Green, J. (2001). Interactional ethnography: An approach to studying the social construction of literate practices. *Linguistics and Education*, 11(4), 353–400.
- Erickson, F. (1992). Ethnographic microanalysis of interaction. In M. D. LeCompte, W. L. Millroy, & J. Preissle (Eds.), *The handbook of qualitative research in education* (pp. 201–225). New York: Academic.
- Erickson, F. (1996). Going for the zone: The social and cognitive ecology of teacher-student interaction in classroom conversations. In D. Hicks (Ed.), *Discourse, learning and schooling* (pp. 29–62). Cambridge: Cambridge University Press.
- Erickson, F. (2004). *Talk and social theory: Ecologies of speaking and listening in everyday life*. Cambridge: Polity Press.
- Erickson, F., & Shultz, J. (1977). ‘When is a context?’ some issues and methods in the analysis of social competence. *The Quarterly Newsletter of the Institute for Comparative Human Development*, 1(2), 5–10. Also (1981) In Green, J. L., & Wallat, C. (Eds.), *Ethnography and language in educational settings* (pp. 147–160). Norwood: Ablex.
- Erickson, F., & Shultz, J. (1982). *The counselor as gatekeeper: Social interaction in interviews*. New York: Academic.
- Fiksdal, S. (1990). *The right time and pace: A microanalysis of cross-cultural gatekeeping interviews*. Norwood: Ablex.
- García-Sánchez, I. M. (2013). The everyday politics of “cultural citizenship” among North African immigrant school children in Spain. *Language & Communication*, 33, 481–499.
- Goffman, E. (1981). *Forms of talk*. Philadelphia: University of Pennsylvania Press.
- Goodwin, C. (1981). *Conversational organization: Interaction between speakers and hearers*. New York: Academic.
- Green, J. L. & Dixon, C. N. (Eds.). (1994). Santa Barbara classroom discourse group [Special issue]. *Linguistics and Education*, 5(3/4), 231–417.
- Green, J., Skukauskaite, A., Dixon, C., & Córdova, R. (2007). Epistemological issues in the analysis of video records: Interactional ethnography as a logic of inquiry. In R. Goldman,

- R. Pea, B. Barron, & S. Derry (Eds.), *Video research in the learning sciences* (pp. 115–132). Mahwah: Lawrence Erlbaum.
- Gumperz, J. J. (1982). *Discourse strategies*. Cambridge: Cambridge University Press.
- Hellermann, J. (2006). Classroom interactive practices for developing L2 literacy: A microethnographic study of two beginning adult learners of English. *Applied Linguistics*, 27(3), 377–404.
- Jaspers, J. (2012). Interactional sociolinguistics and discourse analysis. In J. P. Gee & M. Handford (Eds.), *The Routledge handbook of discourse analysis* (pp. 135–146). New York: Routledge.
- Jennings, L., & Green, J. (Eds.). (1999). Democratic classroom practices [theme issue]. *Journal of Classroom Interaction*, 34(2), i–iv, 1–52.
- Johnson, S. J., & Amador, L. (2011). A pioneer in the use of video for the study of human social interaction: A talk with Frederick Erickson. *Crossroads of Language, Interaction and Culture*, 8(1), 93–102.
- Jung, N. M. (2009). *A (re)produção de identidades sociais na comunidade e na escola [The (re) production of social identities in the community and at school]*. Ponta Grossa: Editora UEPG.
- Kendon, A. (1990). *Conducting interaction: Patterns in focused encounters*. Cambridge: Cambridge University Press.
- McDermott, R. P. (1976). Kids make sense: An ethnographic account of the interactional management of success and failure in one first-grade classroom. (Unpublished doctoral dissertation). Stanford University.
- McDermott, R. P. & Gospodinoff, K. (1979). Social contexts for ethnic borders and school failure. In A. Wolfgang (Ed.), *Nonverbal behavior: Applications and cultural implications* (pp. 175–195). New York: Academic. Also (1981) In H. T. Trueba, G. Guthrie, & K. H. Au (Eds.), *Culture and the bilingual classroom* (pp. 212–230). Rowley: Newbury House.
- McDermott, R. P., & Raley, J. (2011). Looking closely: Toward a natural history of human ingenuity. In E. Margolis & L. Pauwels (Eds.), *The Sage handbook of visual research methods* (pp. 372–391). London: Sage.
- McDermott, R. P., Gospodinoff, K., & Aron, J. (1978). Criteria for an ethnographically adequate description of concerted actions and their contexts. *Semiotica*, 24(3/4), 245–275.
- Mehan, H. (1979). *Learning lessons: Social organization in the classroom*. Cambridge, MA: Harvard University Press.
- Mehan, H. (1998). The study of social interaction in educational settings: Accomplishments and unresolved issues. *Human Development*, 41(4), 245–269.
- Michaels, S. (1981). “Sharing time”: Children’s narrative styles and differential access to literacy. *Language in Society*, 10, 423–442.
- O’Connor, M. C., & Michaels, S. (1996). Shifting participant frameworks: Orchestrating thinking practices in group discussion. In D. Hicks (Ed.), *Discourse, learning and schooling* (pp. 63–103). Cambridge: Cambridge University Press.
- Shultz, J., & Florio, S. (1979). Stop and freeze: The negotiation of social and physical space in a kindergarten/first grade classroom. *Anthropology and Education Quarterly*, 10(3), 166–181.
- Shultz, J., Florio, S., & Erickson, F. (1982). Where’s the floor? Aspects of the cultural organization of social relationships in communication at home and at school. In P. Gilmore & A. A. Glatthorn (Eds.), *Ethnography and education: Children in and out of school* (pp. 88–123). Washington, DC: Center for Applied Linguistics.
- Streeck, J. (1983). *Social order in child communication: A study in microethnography*. Amsterdam: Johns Benjamins.

---

# Interactional Approaches to the Study of Classroom Discourse and Student Learning

John Hellermann and Teppo Jakonen

---

## Abstract

Although a great deal of research has investigated classroom discourse, just a small subset of this research has studied interaction together with learning. This chapter outlines studies of classroom discourse research that have foregrounded interaction and learning. The survey includes research from theoretical perspectives including Vygotskian sociocultural theory, ethnomethodological conversation analysis, and microethnography. The chapter concludes by outlining issues for the future including interactionally oriented definitions of learning, the use of more technologically sophisticated research tools, and more seamless connections between research and practice.

---

## Keywords

Audio recordings • Classroom discourse and student learning, interactional approaches • Coding system • Constructivist approach • Content and language integrated learning (CLIL) • English as a foreign language (EFL) • Ethnomethodological conversation analysis (EMCA) • Initiation-response-evaluation (IRE) • Second language acquisition (SLA) • Sociocultural theory (SCT) • Video recording

---

J. Hellermann (✉)

Department of Applied Linguistics, Portland State University, Portland, OR, USA  
e-mail: [jkh@pdx.edu](mailto:jkh@pdx.edu)

T. Jakonen (✉)

Centre for Applied Language Studies, University of Jyväskylä, Jyväskylä, Finland  
e-mail: [teppo.jakonen@jyu.fi](mailto:teppo.jakonen@jyu.fi)



## Contents

Introduction .....	450
Early Studies .....	450
Major Contributions .....	452
Classroom Research Influenced by Ethnomethodological Conversation	
Analysis (EMCA) .....	453
EMCA Studies of Learning .....	454
Content and Language Integrated Learning (CLIL) .....	455
Work in Progress .....	455
Problems and Difficulties .....	456
Specifying “Learning” .....	456
Research to Practice .....	457
Technological Limitations .....	457
Future Directions .....	458
Theoretical and Empirical .....	458
Data Collection .....	459
Cross-References .....	460
Related Articles in the Encyclopedia of Language and Education .....	460
References .....	460

---

## Introduction

As the title of this chapter includes the terms interaction, classroom, and learning, we start by delimiting the scope of research that we will review. Our discussion is limited to studies of classrooms in which the focus of the research was on “interaction” and “learning,” two constructs that we define in order to justify what research is included or left out of our survey.

For the research reviewed in this chapter, the concept of “interaction” comes out of functional linguistics’ understanding of meaning making (Halliday 1978) and microanalytic studies and methods (particular conversation analysis) that have investigated how language, meaning, and learning is co-constructed in and as interaction. This contrasts to the use of interaction by researchers focused on linguistic structures produced by individuals (see critiques and definitions in Hall and Verplaetse 2000). Our survey includes research on teacher–students interaction and student–student interaction.

Given the complex nature of this context most research on classroom interaction does not explicitly address learning (Macbeth 2011). The studies we review, for the most part, consider interaction as both a context for, and in, learning. We are considering learning to be observable change in competence for a practice that may be accomplished alone but is more easily seen when accomplished through interaction with other people and mediational tools.

---

## Early Studies

Although classroom interaction had been studied before the late 1960s, it was at that time that accessible technology in the form of electronic recording devices allowed more detailed qualitative inquiry and phenomenological studies. Observation and

field notes allow for rich descriptions of selected interactions that occur in classrooms and before accessible electronic recording, checklist observation protocols were the only way to try to make an account of the variety and number of occurrences of different interactions in the classroom. This method, however, does not allow for a nuanced analysis of many interactions.

The earliest large-scale study to rely on video recording of classroom interaction was Bellack et al. (1966). Grounding their analysis in an action-oriented conceptualization of language (*à la* Wittgenstein, Austin), they developed a complex, data-driven categorical system for coding and analysis of transcripts of classroom talk. This system was an attempt to connect interaction to cognition. The coding system includes four pedagogical moves (two initiating and two responsive actions) which are linked to categories of meaning (substantive, substantive-logical, instructional, and instructional-logical). Although the categories were developed based on analysis of interaction in the classroom, their assessments of learning relied on decontextualized quantitative post-assessments of change in attitudes and subject-matter knowledge.

Research by Barnes (1976) was innovative for focusing on student–student interaction in small groups (in elementary schools) and for the claims and demonstrations about how learning occurs via the talk and interaction that occurred in small-group work. The constructivist approach to understanding learning drew on research by Piaget, Vygotsky, and Schütz defining learning as the students’ reshaping of knowledge and information they get from the instructor and one another. This reshaping is done in a reflexive way through exploratory language that allows students to compare their perspective and working formulations of understanding with the facts and evidence provided by the instructor. The reshaping is also made possible by students bringing their previous experiences into small group interaction. Audio recordings were made of the small group interactions and a microgenetic perspective on learning was taken. Although detailed sequential analysis of the interactions was not made, Barnes’ work was radical for focusing on what students make of the communicative patterns of the classroom and how they learn from that. It was also important in suggestions made that curricula be designed based on students’ understandings of the organization of classroom learning.

Other notable early research includes that of Gordon Wells (1986, 2009). This study is based on an ethnographic design for data collection (including audio and video recordings) from children’s spoken interaction and beginning writing at home and in school. Although there is some quantification of language ability and socioeconomic status, the meat of the work is in the transcript excerpts of the language that show the process of students’ interaction at home with parents and siblings and at school with teachers and peers. Also impressive is the longitudinal aspect. Researchers on this study (The Bristol Study) followed 132 randomly selected students from the age of 15 months until the end of their time in elementary school making periodic recordings of their interaction at home (audio) and at school (video). This research shows that students from a variety of socioeconomic backgrounds are experienced with what researchers think of as “schooled” language practices (e.g., display question sequences) because they participated in those

language practices at home. Wells also showed that it is only at the stage in which students become academically literate (around age 10), that correlations between school success, literacy, and socioeconomic background appear, not before. Those students who were successful in school after academic literacy was introduced were the students whose households had a great deal of print materials and who, in school, were good at test preparation and test taking.

The research also suggests that spoken interaction in schools between teacher and students and among students is an important basic opportunity for learning because from this Vygotskian sociocultural theory (SCT) perspective, it is the student that must be part of the negotiation of meaning in order to learn. Unfortunately, in Wells' data such opportunities for negotiation of meaning were not taken advantage of because of the focus of many classrooms on hearing the "right" answer.

Like Wells and Barnes, Cazden's (1988) work is grounded in sociocultural learning theory. It is a comprehensive overview of different aspects of classroom interaction including teacher talk and peer interaction. A chapter deals explicitly with learning processes (a microgenetic perspective). Like these SCT-grounded studies, the starting point is that learning emerges from interactions. The analysis of the interactions themselves is, from an interactional perspective, minimal. That is, crucial prosodic and sequential aspects of the interaction are not dealt with in a systematic way.

Though they did not focus on learning in the way we have limited our discussion in this chapter, two other early studies of classroom discourse need to be mentioned due to their massive influence on the field. Sinclair and Coulthard (1975) and Mehan (1979) theorized a hierarchical taxonomy of nested language structures that make up classroom discourse, the Initiation-Response-Evaluation (IRE), also known as the Initiation-Response-Feedback (IRF) being the most notable. Each study used electronic recording (audio and video, respectively). Mehan's work was grounded in ethnomethodology while Sinclair and Coulthard's was in functional linguistics. The sequential structures these studies identified became formalized and influential for all classroom discourse research that followed.

---

## Major Contributions

The major contributions after the "early studies" we outline are grounded in different theoretical traditions but can be divided, roughly, into those influenced by Vygotskian Sociocultural Theory (SCT) and those influenced by ethnomethodological conversation analysis. The empirical studies and theoretical work in the late 1990s by researchers using SCT (Hall and Verplaetse 2000 among others) were influential in moving the field of second language acquisition (SLA) to reconceptualize the concept of interaction by showing learners engaged in language-related episodes. Studies of interaction and second language (L2) learning in this line take interaction around language itself as a starting point for analysis rather than identifying and quantifying such interactions. SCT is a fully developed theory of learning, and studies of classroom interaction by L2 learners

have focused on interactional competence in general (see recipient behavior in Ohta 2000) and on how SCT concepts in particular (see private speech in Ohta 2001; scaffolding in Donato 1994) lead to learning.

In a study of naturalistic student–student interaction, Donato (1994) focused on student planning for language-learning tasks in university French foreign language classrooms. He showed how, by sharing their different individual competences in single interactions, students were able to co-construct a “scaffold” for learning. This scaffold of shared knowledge allowed them to collaboratively and then to independently use particular lexico-grammar in French. In this study, Donato stressed the importance of examining interaction for the social construction of knowledge rather than as a catalyst for individual processing of input.

Ohta’s work (2000, 2001) also studied nonelicited data from university-level foreign language instruction (Japanese) resulting in a number of longitudinal case studies. Data collection included microphones on focal students and video cameras to capture the classroom context. She made periodic recordings over the course of 1 year. The series of studies show a shift from pre-theoretical empirical work (2000) to work more explicitly grounded in SCT (2001). The first of these studies showed evidence of learners’ development of interactional competence. Studying response tokens, the data show how the two focal students change their practices for using discourse markers (both the forms themselves and the contexts) over the data collection period. In her 2001 book, Ohta used the SCT framework for explaining learning through classroom interaction. The analysis was of the same longitudinal data set and continued to focus on classroom and interactive practices that reflexively led to interactional competence – corrective feedback, recipient behavior, and private speech. This last phenomenon is a construct in SCT, but Ohta’s focus remains clearly interactional showing how learners’ private speech shows how they are projecting what is to come and co-constructing meaning with an interlocutor even though the interlocutor does not hear the learner’s utterances.

### **Classroom Research Influenced by Ethnomethodological Conversation Analysis (EMCA)**

Building on the tradition established by Mehan (1979), Macbeth’s work (1994, 2011 among others) has taken an ethnomethodological approach to understanding classroom interaction in a number of studies of teacher talk with students in, mostly, plenary contexts. In his 2011 paper addressing “understanding,” he encourages classroom researchers to look to the foundational elements of teaching and learning in classroom interaction via talk. The paper outlines several examples of classroom contexts exhibiting that researchers should not look for and expecting to see students providing the teacher with information she does not have (“authentic” information exchange), as students do not and, indeed, cannot “know” what teachers know nor can they know the curriculum. Though they may not “know” an answer elicited by the teacher, they can “do” interaction with the teacher (often, the three-turn IRE sequence). In other instances, students may know that a particular question calls for a

particular answer (perhaps a yes/no answer) but withhold that answer not because they do not know the preferred response but because they do not know why that is the preferred response. This shows the inseparability of “knowing how” from “knowing that” (Ryle 1945). As Macbeth (2011) puts it, “[students] must produce their lessons before they know them” (p. 449) and teachers must show students what it is they do not know.

## EMCA Studies of Learning

The strength of analytic methods from ethnomethodological conversation analysis (EMCA) has recently been noted for tracing classroom learning longitudinally (Pekarek Doehler 2010). The focus on interaction and participants’ perspectives is the strength of CA. Although research in this area has not emphasized longitudinal data collection, researchers interested in learning have realized the power of detailed interactional analyses of longitudinal data sets. The following are a few exemplary studies of classroom learning (interactional competence) in various contexts.

Cekaite (2007) conducted a longitudinal case study (one school year) of a student in an elementary school classroom for immigrants to Sweden. As part of the ethnographic data collection, she made video recordings (90 h) of the interactions of students and used CA methods to show the socialization of the focal student toward classroom interactional competence. The student was shown developing the competence to interact in different languages and to move from one-on-one talk with peers in one language to be able to do multiparty talk in another language.

In a more microlongitudinal study (over the course of four lessons), Melander and Sahlström (2009a) showed how a sequence of actions is learned by examining a teacher’s interaction with a student as they use embodied language practices for questioning and answering. The authors showed in a step-by-step, lesson-by-lesson, way the increasing proficiency in understanding problems in piloting an aircraft and in the ability to remedy them. The use of gesture with talk was shown to be an important aspect to display learning as was the authors’ illustration of how the student moves from joint to individual accomplishment (similar to SCT) as well as how students move from slow, stepwise to fast and integrated action. In their study of an elementary classroom setting, Melander and Sahlström (2009b) demonstrated how across a sequence of four interactions, students themselves make relevant a point for learning by topicalizing the size of a whale and then entrenching their understanding of the size of the whale by comparing it to what they see in their book and to what they know of their real world.

Recent classroom discourse research on language-learning classrooms that does not fit neatly into one or the other of these two theoretical frames has been carried out by Walsh (2011, among others). Walsh’s book focuses on what teachers can learn from understanding the practices for talk by all participants in classrooms. In this work and others, Walsh is eclectic both theoretically (what constitutes learning) and methodologically (how to discover instances of learning), drawing on theory and techniques from CA, SCT, and traditional second language acquisition studies.

---

## Content and Language Integrated Learning (CLIL)

The research highlighted thus far addressed studies of the learning of languages or other subject matter in classrooms devoted to the teaching of one or the other. Modern theories of language acquisition point to the efficacy of contextualized language use as a prime factor for advanced acquisition of a language, and schools have seen that providing students opportunities for contextualized language use can be done by using the language in other subject-matter classes. The previous research on such content and language integrated (CLIL) classrooms has focused on how teachers and students use language when they negotiate content knowledge. One of the most comprehensive accounts of CLIL classroom interaction is provided by Dalton-Puffer (2007), whose cross-sectional and audio-recorded data comes from 14 classrooms in lower and upper secondary schools in Austria. The study combined different theoretical and methodological perspectives to investigate, among other things, classroom questions and academic language. Dalton-Puffer observed that the construction of academic content is largely accomplished through teacher questions looking for “facts” to which students provide very short responses. Moreover, her data included few examples of students explaining, defining, or hypothesizing scientific phenomena, which led her to question the degree to which CLIL classrooms provide opportunities for learning such academic language skills through participation. Slightly different results were obtained by Nikula (2007), who compared the accomplishment of the three-part teaching exchanges (IRE) in CLIL science and English as a foreign language (EFL) lessons in Finnish secondary education. Nikula found that EFL classes relied more heavily on the IRE format and that the IREs in the CLIL database routinely contained sequence expansions that involved justifications and elaborations of student responses, as opposed to the more constrained sequences found in EFL classes.

Other studies focusing on bilingual classroom interaction have investigated the ways in which the dual instructional goals of teaching content and language are managed by the participants. Through a single-case analysis of teacher–student interaction in an English-language immersion class in biology, Pekarek Doehler and Ziegler (2007) argued that interaction in bilingual classrooms is multilayered by showing how in the focal sequence, participants’ orientation to language-related work, such as the pronunciation and choice of scientific terms functions as a “stepping-stone” for scientific work. On the basis of their observations, the authors suggested that practices of “doing science” and “doing language” are inseparable, so that each practice feeds into the other.

---

## Work in Progress

Research, of course, continues for many of the authors already cited in our review so we can mention just a few recent and innovative areas here. Seedhouse and colleagues (2014) have built a technologically sophisticated design for foreign language learning that incorporates insights from CLIL and task-based learning. The design is

a digitally monitored kitchen in which learners interact with objects in the foreign language as they prepare particular recipes. Kitchen appliances and tools use voice technology to provide language instruction and language input to learners as they accomplish particular cooking tasks. As each tool and appliance used for the making of particular products is digitally monitored, immediate feedback is given to learners in the language they are learning during the process of food preparation. Learners may work together on recipes so there is both human–human interaction as well as human–object interaction during the process.

A recent longitudinal study in a CLIL context is longitudinal and focuses on the interactional nature of learning. Using data from 15 consecutive lessons from a CLIL history classroom, Jakonen (2014) analyzed interactional sequences that begin when a student conveys lack of knowledge toward some aspect of the ongoing instruction or pedagogic task. Finding that most of the time students resolved lack of knowledge in peer interaction as opposed to soliciting the teacher, Jakonen analyzed both the interactional organization of such sequences and how they could be seen to contribute toward learning in the classroom. He argued that students oriented to learning in two different ways. Firstly, students “did learning” when they identified a knowledge object and solicited information from another classroom member in order to become to know it. Secondly, students sometimes invoked information and knowledge states displayed in some previous events in order to make new social actions meaningful and understandable to the recipient at some later point in the course.

Research by Gosen and colleagues (2015) is also longitudinal in scope and uses CA methods to illustrate learning processes of kindergarten children learning to read. Examining the interactional details of interaction by students and their teachers in kindergarten classes in the Netherlands, this study shows how the sequential structure of talk in different participation structures (shared reading and open discussion) led to the co-construction of conceptual knowledge. Participation in these activities is shown to be oriented to quickly and provides opportunities for student participation and learning.

---

## Problems and Difficulties

Despite the heading for this section, we discuss here exciting reconceptualizations of some tricky theoretical and practical issues in the field. These include practice-oriented conceptualizations of learning, the “research to practice” process, and technology shaping research and analysis.

## Specifying “Learning”

We gave our working definition of learning at the start of the chapter, in part, because the concept of learning has been claimed by different epistemological traditions. The distinction of an individual’s decontextualized competence (“know that”) from that

individual's competence in performance with others ("know how") is an artificial separation (Ryle 1945). Research on and the assessment of learning has privileged the former. However, the study of interaction, the study of practice, is the study of public displays of and toward "knowing how." In the past 10 years, some researchers of interaction have attempted to find ways to find comparable contexts of interaction at different points in time to suggest evidence of change or learning, while others have remained focused on descriptions of contextualized learning practices (Koschmann 2011; Pekarek Doehler 2010).

Yet another distinction can be made between "instruction," provided in and through teacher talk, and "learning," in the sense of what students take away from instruction or other interaction in the classroom. This difference has not always been clear in prior empirical studies. Student participation in the same instruction can take very different forms within the same cohort; therefore, teaching objects do not necessarily represent learning objects to every student in the classroom. Moreover, in situations when students work on learning objects among themselves, this can give rise to practices that are quite different from instruction, such as the "indigenous assessment" (Mori and Hasegawa 2009) of each other's level of knowledge in order to determine whether the co-conversant's assistance is actually "worthwhile." This, together with other differences in learner participation in teacher-led instruction and peer interaction, indicates that the two organizations of classroom discourse have different relevance to learners.

## Research to Practice

The dissemination of findings to policy makers remains a challenge as unrealistic notions of efficiency and one-size-fits-all education remains the dominant discourse among policy makers in the USA and other countries. Rather than try to change this theoretical misunderstanding from the top down, that is, by promoting new theory, a more grounded solution may be necessary (Koschmann 2011). Researchers might think of by-passing the research to theory step by making findings from their classroom studies available first-hand to practitioners and supervisors by including practitioners in the design and implementation of research. Rather than simply advocating new theory for policy makers or calling for more action research designs, research faculty can design projects that give practitioners positions on research teams so that analysis and discussion of data are parts of their work. In this way, the research to practice path is seamless and findings from research on classrooms and implications for practice are experienced by site practitioners and, perhaps, their immediate supervisors.

## Technological Limitations

The changing nature of classrooms makes new research methodologies imperative. For video-based research, recording protocols need to be digital and more limber.



The classroom now includes digital virtual information that is connected to the physical space of the classroom. Model pedagogy has long focused on experiential learning, and the use of portable digital tools can now allow students and teachers to be more mobile, physically as well as virtually. Contexts for learning are more easily accessible with the use of portable digital tools and video-based research needs to develop portable systems for capturing mobile learning situations with multiple, synchronized camera views. Seedhouse et al. (2014), as discussed earlier, has presented technological innovations that will help researchers and practitioners reimagine classrooms.

---

## Future Directions

Looking to the future for research on interaction and learning, we want to highlight two themes: (1) the need for continued theoretical elaboration via empirical research and (2) how technologies will change the nature of data collection and locations for learning (classrooms).

## Theoretical and Empirical

Although we noted early that defining learning can be considered a “problem” for interactional classroom research, recent empirical work on classroom interaction has fostered a renewed interest in doing this definitional work (Kasper and Wagner 2011). This is less of an issue for the research grounded in sociocultural theory, a well-defined theory of learning. Sociointeractive approaches to understanding learning have eschewed the strict process-product divide and remained agnostic on whether we can see and know a process of internalization (a construct in SCT). These discussions include, among others, (1) whether we define the focus for learning on symbolic objects or interactional process, (2) whether we define learning as long-term change or synchronic, (3) locating and defining objects or processes that researchers and learners themselves focus on, and (4) to what degree researchers and teachers should consider these foci for learning to be individual, portable, pan-contextual competences. Discussion around these and other questions will continue, as will empirical studies to support that discussion.

The 50 years of study of classroom interaction has established, not surprisingly, that orderly language use for teaching and learning is a complex process. The many empirical studies of interaction, only some of which we could review here, offer examples of how interaction facilitates changes in the ways learners know and perform the subject matter of their learning. There are very general recommendations that can be made for teaching and learning based on this research (e.g., interaction among students is, in most cases, beneficial for learning; language use is not simply a cognitive conduit to learning but is raw material for students to draw on to support

their learning). The most important conclusion one might make from this research is, perhaps, that curriculum and pedagogies need to take advantage of the contingencies of different contexts and participants in those contexts rather than treat them as annoyances to plan around or avoid.

## Data Collection

This survey of the research from the past 50 years also shows that the field can benefit from the use of more thoughtfully planned intensive video recording projects that use digital technologies to construct synchronized data collection systems. Classroom video recording is often periodic and not comprehensive leading to studies of instances in time in the classroom. Ethnographies of classrooms are, of course, an exception but even those studies rarely use intensive, systematic, and longitudinal video recording. One model for such a project, now over 10 years old, is the ClassAction project (Reder et al. 2003) in which 4 years of data from two classrooms (six cameras and five microphones in each classroom) captured longitudinal data of beginning learners of English. The data collection system includes software for displaying the six video and audio channels synchronized for ease of analysis and allows video to be streamed for analysis and dissemination of findings. Along with this intensive recording protocol for capturing physical interaction, technology is also now available for capturing the real-time use of the digital tools (tablets, phones, smart boards) used by students and instructors and those can become part of corpora of intensive video recordings.

One caveat here is that with more intensive recording of video and audio in classroom settings, researchers can find themselves observing an etic discursive landscape. That is, the researcher may be able to observe talk and interaction that occurs in the classroom that may not be observable and, therefore, not relevant for a number of participants in that classroom.

Although educational policy is slow to change, positive changes that have been made can be attributed, in many cases, to the empirical findings from research on classroom interaction. Interaction that occurs in the classroom is not seen as incidental to learning but part of the raw material for learning. The understanding of the role of interaction in classroom learning has also been and will continue to be important for the use of digital and mobile technologies for learning (as discussed earlier). Studies of digital technology must (and usually do) consider the role of human–human or human–digital interaction in their analyses. This is allowing us not only to imagine but to carefully consider the positive and negative roles of digital resources on learning and help shape what learning contexts will be in the future. Digital technology is providing new sites and tools for engaging learners and the role of interaction during and for the use of such technologies is a growing research interest. What is more, the mobility made possible by new digital technologies make that interaction all the more complex for analysis (Thorne et al. 2015) and may radically change what we think of as a “classroom.”

## Cross-References

- ▶ [Conversation Analytic Approaches to Language and Education](#)
- ▶ [Microethnography in the Classroom](#)
- ▶ [Researching Developing Discourses and Competences in Immersion Classrooms](#)

---

## Related Articles in the Encyclopedia of Language and Education

- Judith Green and Janet Joo: [Classroom Interaction, Situated Learning](#). In Volume: Discourse and Education
- Numa Markee and Silvia Kunitz: [Understanding the Fuzzy Borders of Context in Conversation Analysis and Ethnography](#). In Volume: Discourse and Education
- Rémi A. van Compernelle: [Sociocultural Approaches to Technology Use in Language Education](#). In Volume: Language, Education, and Technology
- Silvia Valencia Giraldo: [Talk, Texts and Meaning-Making in Classroom Contexts](#). In Volume: Discourse and Education

---

## References

- Barnes, D. (1976). *From communication to curriculum*. London: Penguin.
- Bellack, A. A., Kliebard, H. M., Hyman, R. T., & Smith, F. L. (1966). *The language of the classroom*. New York: Teachers College Press.
- Cazden, C. B. (1988). *Classroom discourse: The language of teaching and learning*. Portsmouth: Heinemann.
- Cekaite, A. (2007). A child's development of interactional competence in a Swedish L2 classroom. *Modern Language Journal*, 91(1), 45–62.
- Dalton-Puffer, C. (2007). *Discourse in content and language integrated learning (CLIL) classrooms*. Amsterdam: John Benjamins Publishing Company.
- Donato, R. (1994). Collective scaffolding in second language learning. In J. P. Lantolf & G. Appel (Eds.), *Vygotskian approaches to second language research* (pp. 33–56). Norwood: Ablex.
- Gosen, M. N., Berenst, J., & de Glopper, K. (2015). Shared reading at kindergarten: Understanding book content through participation. *Pragmatics and Society*, 6(3), 367–397.
- Hall, J. K., & Verplaeste, L. S. (Eds.). (2000). *Second and foreign language learning through classroom interaction*. Mahwah: Lawrence Erlbaum Associates.
- Halliday, M. A. K. (1978). *Language as social semiotic: The social interpretation of language and meaning*. London: Edward Arnold.
- Jakonen, T. (2014). *Knowing matters: How students address lack of knowledge in bilingual classroom interaction*. Finland: University of Jyväskylä.
- Kasper, G., & Wagner, J. (2011). A conversation-analytic approach to second language acquisition. In D. Atkinson (Ed.), *Alternative approaches to second language acquisition* (pp. 117–142). New York: Taylor & Francis.
- Koschmann, T. D. (Ed.). (2011). *Theories of learning and studies of instructional practice*. New York: Springer.
- Macbeth, D. (1994). Classroom encounters with the unspeakable: “Do you see, Danelle?”. *Discourse Processes*, 17(2), 311–335.
- Macbeth, D. (2011). Understanding as an instructional matter. *Journal of Pragmatics*, 43(2), 438–451.

- Mehan, H. (1979). *Learning lessons: Social organization in the classroom*. Cambridge, MA: Harvard University Press.
- Melander, H., & Sahlström, F. (2009a). In tow of the blue whale: Learning as interactional changes in topical orientation. *Journal of Pragmatics*, 41(8), 1519–1537.
- Melander, H., & Sahlström, F. (2009b). Learning to fly: The progressive development of situation awareness. *Scandinavian Journal of Educational Research*, 53(2), 151–166.
- Mori, J., & Hasegawa, A. (2009). Doing being a foreign language learner in a classroom: Embodiment of cognitive states as social events. *IRAL – International Review of Applied Linguistics in Language Teaching*, 47(1), 65–94.
- Nikula, T. (2007). The IRF pattern and space for interaction: Comparing CLIL and EFL classrooms. In C. Dalton-Puffer, T. Nikula, & U. Smit (Eds.), *Empirical perspectives on CLIL classroom discourse* (pp. 179–204). Frankfurt: Peter Lang.
- Ohta, A. (2000). A longitudinal study of the development of expression of alignment in Japanese as a foreign language. In K. R. Rose & G. Kasper (Eds.), *Pragmatics in language teaching* (pp. 103–120). Cambridge: Cambridge University Press.
- Ohta, A. S. (2001). *Second language acquisition processes in the classroom: Learning Japanese*. Mahwah: Lawrence Erlbaum Associates.
- Pekarek Doehler, S. (2010). Conceptual changes and methodological challenges: On language and learning from a conversation analytic perspective on SLA. In P. Seedhouse, S. Walsh, & C. Jenks (Eds.), *Conceptualising learning in applied linguistics* (pp. 105–127). Basingstoke: Palgrave Macmillan.
- Pekarek Doehler, S., & Ziegler, G. (2007). Doing language, doing science and the sequential organization of the immersion classroom. In H. Zhu, P. Seedhouse, W. Li, & V. Cook (Eds.), *Language learning and teaching as social inter-action* (pp. 72–86). Basingstoke: Palgrave Macmillan.
- Reder, S., Harris, K., & Setzler, K. (2003). A multimedia adult learner corpus. *TESOL Quarterly*, 37(3), 546–557.
- Ryle, G. (1945). Knowing how and knowing that. London: Meeting of the Aristotelian Society at the University of London Club.
- Seedhouse, P., Preston, A., Olivier, P., Jackson, D., Heslop, P., Balaam, M., Rafiev, A., & Kipling, M. (2014). The European digital kitchen project. *Bellaterra Journal of Teaching & Learning Language & Literature*, 7(1), 1–16.
- Sinclair, J. M., & Coulthard, R. M. (1975). *Towards an analysis of discourse: The English used by teachers and pupils*. London: Oxford University Press.
- Thorne, S. L., Hellermann, J., Jones, A., & Lester, D. (2015). Interactional practices and artifact orientation in mobile augmented reality game play. *Psychology*, 13(2–3), 259–286.
- Walsh, S. (2011). *Exploring classroom discourse: Language in action*. Abingdon: Routledge.
- Wells, G. (1986). *The meaning makers: Children learning language and using language to learn*. Portsmouth: Heinemann.
- Wells, G. (2009). *The meaning makers: Learning to talk and talking to learn* (2nd ed.). Bristol: Multilingual Matters.

---

# Conversation Analytic Approaches to Language and Education

Hansun Zhang Waring

---

## Abstract

This chapter documents the impact of conversation analysis (CA) as a research method on language education. Beginning with the earlier crossover between CA and applied linguistics on the campus of UCLA, it proceeds to sketch how conversation analytic findings have enriched our understandings of the nature of interactional competence, the complexity of pedagogical practices, and finally, the very conceptualization of learning and how that learning is accomplished. It also paints in broad strokes the current trends of CA work on language education and highlights such challenges as translating CA insights into the classroom, illuminating teacher expertise, and cultivating a broader view of learning. The chapter concludes by delineating some future directions where some of these challenges may be addressed.

---

## Keywords

Conversation Analysis • Applied Linguistics • Interactional Competence • Language Teaching • Language Learning

## Contents

Introduction .....	464
Early Developments .....	464
Major Contributions .....	466
CA and Interactional Competence .....	466
CA and Language Teaching .....	467
CA and Language Learning .....	468
Work in Progress .....	469

---

H.Z. Waring (✉)

Applied Linguistics and TESOL, Teachers College, Columbia University, New York, NY, USA

e-mail: [hz30@tc.columbia.edu](mailto:hz30@tc.columbia.edu)

Problems and Difficulties .....	470
Future Directions .....	471
Cross-References .....	472
Related Articles in the Encyclopedia of Language and Education .....	472
References .....	472

---

## Introduction

The field of language education has witnessed exponential growth in harnessing the methodological power of conversation analysis (CA) to address issues of teaching and learning, forcing us to reconsider some of the fundamental questions such as what needs to be taught, how teaching is done, and how learning proceeds. To date, aside from its presence in numerous edited volumes as well as special journal issues, CA research has left an indelible mark, if not become a staple, at major conferences such as TESOL (International Association for Teachers of English to Speakers of Other Languages), AAAL (American Association for Applied Linguistics), and IPrA (International Pragmatics Association) as well as in leading journals such as *TESOL Quarterly*, *Applied Linguistics*, *Language Learning*, *Linguistics and Education*, and *The Modern Language Journal*. In this chapter, I charter CA's journey into the field of language education and highlight its major contributions to our understandings of the nature of interactional competence, the nature of language learning, and the nature of language teaching. Throughout the chapter, I emphasize CA's methodological forte that affords these unique contributions that would have otherwise remained inaccessible to intuitions or interviews. Despite this robust growth, conversation analytic work addressed to language education is not without its problems and difficulties, a few of which I shall briefly outline. Finally, I venture to sketch some directions for future research.

---

## Early Developments

Championed by sociologists Harvey Sacks, Emmanuel Schegloff, and Gail Jefferson, CA emerged as a radical approach to sociological inquiry in the 1960s. As a research methodology, it insists on using data collected from naturally occurring interaction as opposed to interviews, field notes, native intuitions, and experimental designs and letting research questions emerge from such data. Analysts work with audio or video recordings along with the transcripts of these recordings, using transcription notations that capture a full range of interactional details such as volume, pitch, pace, intonation, overlap, inbreath, smiley voice, the length of silence as well as nonverbal conduct. It is in such minute details that evidence for the tacit methods of social interaction – those often not subject to easy articulation – is located. This stance toward prioritizing naturally occurring interaction and on-the-scene participant orientations quickly proved attractive to scholars from a variety of disciplines such as anthropology, psychology, and communication studies.

The field of language education was no exception. Early cross-over between CA and applied linguistics/SLA (second language acquisition) took shape on the campus of UCLA during mid 1970s–1980s (Wong 2013), where a series of master theses began to apply CA to the analysis of conversations that involved nonnative speakers and to argue for the relevance of CA for language teaching. In her 1984 thesis (later published as Wong 2002), for example, Wong evaluated telephone conversations in ESL (English as a second language) textbooks based on CA findings on real-life telephone conversations, revealing such surprising facts as the absence of ringing, the irrelevance of voice samples, or the perplexing discrepancy between talk and participant relationships in textbook phone conversations. From the vantage point of CA, Wong sounded the first wake-up call to language teaching professionals regarding the inauthenticity of textbook materials and how such inauthenticity may be assessed and alleviated. This wielding of CA as an assessment tool for textbook dialogs speaks most directly to CA's relevance for and contribution to language education, and it inspired a line of subsequent work addressed to the design of language teaching materials and activities.

Less directly, CA's bearing on language education became manifest in earlier attempts to examine NS-NNS (native-nonnative) or NNS-NNS conversations. Insofar as much of the enterprise of language education hinges upon our understanding of how language is learned, and much of language learning takes place in interactions both in and outside the classroom as learners interact not only with native speakers but also amongst themselves, understanding the nature of those interactions is pivotal to making informed decisions in both designing and implementing language education practices. Schwartz (1980) (based on her 1977 thesis completed at UCLA), for example, analyzed conversations between ESL learners from a CA perspective, and in particular, the repair work involved in negotiating errors and trouble sources. She found that although the ESL learners' repair practices bear much resemblance to those of native speakers, they do deviate in one respect: in the cases of language errors, the preference for self repair is suspended in favor of other repair, which, according to Schwartz, "might suggest that second language learners can learn more from one another than they think they can" (p. 152). Despite such earlier attempts to apply CA to the study of NNS discourse, it was not until almost 20 years later that the urgency of examining such discourse for applied linguists was explicitly articulated by Firth and Wagner (1997), and a programmatic call made to broaden the scope of SLA (second language acquisition) to accommodate both the social and cognitive dimensions of language use and acquisition. Only in so doing, maintained Firth and Wagner, may a better understanding of "how language is used *as it is being acquired through interaction*" be achieved (p. 296, emphasis in original). Although Firth and Wagner made no explicit reference to conversation analysis in their programmatic call, given its potency in describing and detailing the practices of social interaction, CA became the natural candidate for answering that call. As we shall see in the following section, aside from specifying the nature of interactional competence, CA scholars have made important advance in illuminating the nature of language learning as well as that of language teaching.

## Major Contributions

### CA and Interactional Competence

Crystallized in the intersection between CA and language education is their common interest in and commitment to the enterprise of interactional competence. For CA, it is the description of such competence, and for language education, its development. Respectively, CA studies on L1 (first language) and L2 (second language) interactional practices offer crucial insights into the nature of L1 and L2 interactional competencies, answering such foundational questions as: what is entailed in the competence to be developed, and what is the nature of such developing competence?

A useful summary of major CA findings on L1 interactional practices can be found in Wong and Waring (2010), who also show how understanding such practices as turn-taking, sequencing, overall structuring, and repair are relevant, and can be applied, to ESL/EFL teaching. CA findings can, as mentioned earlier, serve as a yardstick for measuring the authenticity of various aspects of interactional competence as represented in language teaching materials (Wong 2002). Barraja-Rohan (2011) relates CA specifically to the teaching of interactional competence to lower to intermediate levels adult ESL students, showing how a CA-informed pedagogical approach can effectively raise students' awareness of the norms of spoken interaction and help them become analysts of, and eventually better participants in, conversations. Huth and Taleghani-Nikazm (2006) make the most explicit connection between conversation analysis and the teaching of pragmatics, positing that CA findings "capture pragmatics in its most natural locus: the conversational encounter" (p. 53). The authors demonstrate how CA-based materials can "effectively enable L2 learners to engage in cross-culturally variable language behavior inside and outside of class" (p. 53).

While findings on L1 interactional practices can clearly benefit the design of language teaching materials and instructional activities, understanding the nature of L2 interactional practices is arguably equally integral to assuming an informed pedagogical stance. Importantly, an emic portrayal of learner behavior can help us develop greater clarity in understanding learner "errors" and devise more profitable pedagogical interventions accordingly. In Carroll's (2005) revealing study of vowel-marking (adding vowels to word final consonants) among Japanese learners of English, for example, what is typically attributed to negative transfer is shown to be deployed by the participants as a resource for managing word search and multiunit turns. Indeed, viewing L2 conversations as an exhibit of achievement rather than deficiencies is a prevailing theme in Gardner and Wagner's (2004) edited volume that brings together a series of CA studies showing second language conversations as normal conversations, where errors and mistakes are rarely consequential, and where L2 users exhibit great sophistication and versatility in managing various interactional contingencies. This reconceptualized view of L2 competencies can ultimately alter some of our deep-seated assumptions and routine practices in language education. In discussing the implications for his finding, for example,



Carroll (2005) advises ESL teachers “intent on ridding their Japanese students of vowel-marking” to “forget pronunciation drills and ridicule, and instead concentrate on training students to use interactionally equivalent conversational micro-practices” (p. 233).

In sum, aside from constituting the foundational repertoire of L1 interactional practices, CA findings have also provided crucial insights that have led to a reconceptualization of L2 interactional practices – a reconceptualization that would not have been arrived at without CA’s deeply emic research stance that prioritizes participant orientations.

## CA and Language Teaching

CA contributes to our understanding of language teaching by portraying in great detail the “amazingly complex and demanding interactional and pedagogical work in the classroom” (Seedhouse 2004, p. 265) as teachers manage “the reflexive relationship between pedagogy and interaction” (p. 263) from one moment to the next. Such complex demands of teaching are usefully captured in the construct of classroom interactional competence (CIC) (Walsh 2006) – the ability to use interaction as a tool to mediate and assist learning. As Walsh writes, “[a]lthough CIC is not the sole domain of teachers, it is still very much determined by them” (p. 130). CA studies in the language classroom have yielded useful descriptions of how participation is promoted (Richards 2006), instructions are given (Seedhouse 2008), and explanations are offered (Mortensen 2011).

A noticeable focus of CA research on language teaching falls under what may be called the contingent management of learner contributions. Yes-no questions in the third position after learner responses to teacher initiations, for example, can be used to “pull into view interpretative resources that are already in the room for students to recognize” (Lee 2008, p. 237). In addition, managing learner contributions frequently involves dealing with problematic learner talk. In the native-nonnative speaker conversation groups, covert third position repair is deployed in response to sequentially inapposite responses as a useful resource for keeping the conversation going (Kasper and Kim 2007). In second language writing conferences, teachers use questions that convey information (Koshik 2010) to promote self-correction.

In sum, what such findings have offered overall is a richer and more nuanced depiction of what the professional work of language teaching entails. Such work, as can be seen, is not limited to asking display vs. referential questions or choosing one corrective feedback technique over another. This richness and nuance is a byproduct of how CA research is approached in the first place. By beginning with a line-by-line analysis of the data without any a priori focus, the investigator is able to remain maximally open to what the participants themselves bring to the scene of the interaction, and as a result, produce reports that privilege interaction as experienced and oriented to by the participants, as opposed to ones that favor the analysts’ interpretive stance driven by their particular sets of theoretical or empirical interests.

## CA and Language Learning

While the issue of whether CA can usefully contribute to answering questions of language learning has been hotly debated (see 1997–1998, 2004, and 2007 special issues of *The Modern Language Journal*), those debates will not be rehashed here. Instead, the reader is invited to consider two bodies of CA work that either (1) describes the local interactional process by which learning as a process is negotiated (i.e., learning opportunities) or (2) documents learning as a product in the short term (Markee 2008) or over a longer period of time (Hellermann 2008). Importantly, for these scholars, the fundamental assumption is that both learning and learning opportunities are embedded and embodied in various interactional practices observed both within and outside the classroom. This particular focus necessarily precludes discussions of work addressed to, for example, patterns of classroom discourse without any explicit reference to learning.

**Learning opportunities.** In mining for learning opportunities in the interactional data, CA scholars have repeatedly drawn our attention to learner practices of repair and various types of searches in contexts ranging from the casual to the institutional (Brouwer 2003; Reichert and Liebscher 2012). In examining casual conversations between L1 and L2 English speakers, for example, Kim (2012) shows how practices for establishing initial recognitional reference when names are not available provide design features that can facilitate learning because, as she argues, such practices exhibit a sensitivity to the learner's ZPD (Zone of Proximal Development) (Vygotsky 1978), and "the juxtaposition of the learner's lengthy and often non-target-like utterance to the single lexical item provided by the L1 speaker increases the saliency for noticing" (p. 726).

The discussion of learning opportunity is often bound up with identity negotiations in learning encounters. Hosoda (2006), for example, shows how different levels of language expertise are made relevant by the participants in second language conversations. In Firth's (2009) study on lingua franca in the workplace, on the other hand, participants go to great lengths to disavow their learner status, which entails, as Firth argues, various types of local learning such as quick assessment of recipient competency and adjustment to that competency.

Aside from identity, task seems to be another locus for investigating learning opportunities. Examining a peer interactive task in a Japanese as a foreign language classroom, Mori (2004) shows how the students shift back and forth between working on an assigned task and managing certain lexical problems, thus transforming "in a moment-by-moment fashion their converging or diverging orientations towards varying types of learning and learning opportunities" (p. 536). On the other hand, Markee (2005) draws our attention to off-task talk and its learning potential by virtue of its attention to learners' real interactional needs. Finally, learning opportunities have also been explored in learner behavior such as learner initiatives. Garton (2012), for example, urges teachers to encourage learner initiatives in teacher-fronted classrooms as they constitute significant opportunities for learning.

**Learning over time.** Some scholars have focused on how learning a particular vocabulary item or grammatical structure is achieved within local interactional contexts in the short term. Using evidence from a training course in an American university for 15 science professors from China, Markee (2008) documents how the word “pre-requisite” is first delivered and glossed by the teacher as part of a powerpoint presentation on developing course syllabi and, 2 days later, oriented to as a learning object by the teacher throughout a repair sequence that results in the learner repeating the word along with an independent gloss.

Others document the development of interactional competence over a longer period of time. Nguyen (2012) demonstrate an ESL learner’s increasing participation in grasping the structural organization of a communicative event during office hour interactions over a period of 5–6 weeks. In a series of studies, Hellermann (e.g., 2008) documents ESL learners’ changing participation in managing task opening and closing, storytelling, repair practices, and literacy events over various periods of up to 27 months.

Notably, because of its methodological focus on members’ management of moment-to-moment interaction, CA has recalibrated our investigative gaze into language learning in at least two ways. It has forced us to recognize and appreciate how participants themselves do learning through managing repairs, navigating tasks, and negotiating identities. It has also, importantly, reminded us that language learning is, to a great extent, learning to become competent in mobilizing a wide range of interactional practices.

---

## Work in Progress

Efforts of documenting learning over time continue to characterize some of the current CA work in the language classroom, which explores, for example, how learners develop negation over a seven-month period (Hauser 2013) or how they develop the ability to manage routine inquiries over the span of 9 weeks (Waring 2013a). Similarly, repair and various types of searches remain a magnet for scholarly attention. The practice of epistemic search sequence (ESS) is the focus of Jakonen and Morton’s (2015) study on content-based language classrooms, where students in peer interaction collectively resolve emerging knowledge gaps while working on pedagogic tasks, which, as the authors argue, showcases the affordances of peer interaction for learning. In the meantime, learning opportunities have also been explored in CA studies on a wider range of learner behavior such as multiple responses to teachers’ questions (Ko 2014) and humorous and playful sequences (Reddington and Waring 2015). Multiple responses to teacher questions, for example, are shown to provide an opportunity for learners to share participation and collaboratively achieve a local learning objective (Ko 2014).

In studies on language teaching, a major object of inquiry remains to be the contingent management of learner contribution, as researchers investigate the use of epistemic status checks (ESCs) in response to student visual cue in the interest of

moving the lesson forward (Sert 2013) and the variable functions of third turn repeats in form-and-accuracy versus meaning and fluency contexts (Park 2014). Also placed under the CA microscope is a broader spectrum of pedagogical work such as maintaining the instructional space via self-talk during moments of trouble (Hall and Smotrova 2013), managing the “chaos” of competing voices (Waring 2013b), and creating space for learning through practices such as increased wait-time, extended learner turns and increased planning time, and managing learner contributions in a positive and open way (Walsh and Li 2013). A useful construct that encapsulates such endeavors to document a broader repertoire of teacher conduct is the *interactional competence for teaching* (ICT) (cf. CIC-classroom interactional competence in Walsh 2006) proposed by Joan Kelly Hall at a 2014 AAAL colloquium.

---

## Problems and Difficulties

The meticulous attention to details celebrated as the hallmark of the CA method also presents, unfortunately, a major obstacle to translating its insights into actual classroom teaching. It is difficult, for example, to explicate and make usable the wealth of CA findings without relying on its transcripts that are highly technical and not necessarily visually inviting – at least not at a first glance. CA scholars are typically not at the same time practicing material developers and classroom instructors, and language teaching professionals are mostly not well versed in conversation analysis as a methodology or familiar with its body of findings on interactional competence. Although Wong and Waring (2010) have taken a first systematic attempt at making those findings available and relevant, and heroic efforts have been made or are underway (Jean Wong, personal communication) to develop CA-informed pedagogical materials and instructional activities, these efforts remain limited in amount and reach as the work demands a special kind of expertise, a great deal of creativity, and a high level of labor-intensive energy. The challenge, for example, of presenting CA discoveries on interaction with appeal and efficiency and yet without losing their richness and depths is a serious one. As such, for some, the impact of conversation analysis on the field of language education remains unimpressive at the moment.

Moreover, in their efforts to explicate the interactional competence for teaching (ICT), CA studies have not been particularly discriminatory in choosing the types of teachers to be studied. While we are not in shortage of CA studies of classroom discourse, few focus specifically on experienced teachers and the development of novice teachers. Studies would typically report data from, for example, *a* classroom or a particular set of classrooms, without particular attention to the level of expertise brought in by the teachers. It is true that even without such a focus, we gain valuable insights into how various aspects of teaching are accomplished and accomplished with great ingenuity at times. Calibrating our lens to specifically capture the interactional development and enactment of teacher expertise, however, could yield greater dividend for strengthening the professional practices of language teaching.

In order to garner truly useful feedback for language teacher education purposes, we are yet to build a strong and comprehensive knowledge base of how novice teacher develop over time and what expert teachers do and do well.

Last but not least, a longstanding challenge also concerns the uneasy partnership between CA and language learning, as most poignantly featured in the CA-for-SLA movement. As Pekarek Doehler (2010) maintains, finding ways to look at language-in-action across time, which involves “tracking language resources used within the same type of practice at (at least) two different moments in time” poses particular challenges given “CA’s uncompromising insistence on naturally-occurring data” (pp. 120–121). Lee (2010) raises a more serious issue regarding the very conceptualization of learning in CA-based studies, observing that the initiative to consider learning issues appears to “take the narrower view of learning than what natural interactional details in CA studies allow us to see” (p. 403). He writes:

[t]he contingency of interaction has to be treated as central if we want to recover learning as the participants experience it. . . .if the contingency of interactional details is treated as being analytically central, CA research can still tell us very useful things about the phenomena of learning because it can recover the participants’ contingent sense-making practices through which the task of learning is discovered, acted on, and realized (p. 403).

---

## Future Directions

Clearly, continuing advancement of the CA and language learning program will entail producing stronger evidence and argument for the in situ nature of learning as it is experienced by the participants. It will also hinge upon our abilities to meet the challenge of documenting language-in-action across time. On a more practical front, to further the impact of conversation analysis on language education, great benefits may be gained from richer dialogs and more fruitful collaborations between CA scholars and language teaching professionals. Given various practical constraints, this is (only) possible if we embark on changes at the level of infrastructure – by fronting the relevance of conversation analysis and making it an integral component of language teacher education. Also crucial is serious collaboration between conversation analysts and language teacher education scholars, which will allow for a richer program of language teacher education that prioritizes the development of not only teachers’ interactional practices but also their pedagogical reasoning (Johnson and Golombek 2011).

Finally, serious theory building around the interactional competence for teaching (ICT) will require disciplined empirical work on a wider range of teacher practices with greater specificity. After all, teachers manage numerous challenges in the classroom, and handling such challenges competently is integral to their ICT. Classroom discourse researchers working within a conversation analytic framework may be compelled to address such practical concerns as:

- (1) How do we encourage “conversation,” which is the essence of interactional competence, in an environment that is not a natural habitat to such conversation?
- (2) How do we encourage play and exploration without undermining necessary control? Or conversely, how do we maintain control without undermining participation?
- (3) How do we assess performance in ways that assist performance?
- (4) How do we resolve the paradox of authenticity, where authentic interaction is often off-task, and where greater participation entails less authentic interaction/pragmatic norms?
- (5) How do we ensure robust and inclusive participation in whole-class settings?

In closing, much may be gained from cultivating an appreciation for descriptive work on pedagogical practices, and by extension, an appreciation for the contingency of interaction that such descriptive work illuminates. Adequate descriptions of such practices, as Lee (2013) reminds us, provide educators with “insightful observational resources for their pedagogical gazes” (p. 864), and in particular, allow analysts to “determine what changes are possible in L2 use and what actually occasions those changes” (p. 864).

---

## Cross-References

- ▶ [Interactional Approaches to the Study of Classroom Discourse and Student Learning](#)
- ▶ [Researching Body Movements and Interaction in Education](#)

---

## Related Articles in the Encyclopedia of Language and Education

- Judith Green and Janet Joo: [Classroom Interaction, Situated Learning](#). In Volume: Discourse and Education
- Marije Michel and Bryan Smith: [Computer-Mediated Communication and Conversation Analysis](#). In Volume: Language, Education, and Technology
- Numa Markee and Silvia Kunitz: [Understanding the Fuzzy Borders of Context in Conversation Analysis and Ethnography](#). In Volume: Discourse and Education
- Silvia Valencia Giraldo: [Talk, Texts and Meaning-making in Classroom Contexts](#). In Volume: Discourse and Education

---

## References

- Barraja-Rohan, A. (2011). Using conversation analysis in the second language classroom to teach interactional competence. *Language Teaching Research*, 15(4), 479–507.
- Brouwer, C. E. (2003). Word searches in NNS-NS interaction: Opportunities for language learning? *The Modern Language Journal*, 87(4), 534–545.

- Carroll, D. (2005). Vowel-marking as an interactional resource in Japanese novice ESL conversation. In K. Richards & P. Seedhouse (Eds.), *Applying conversation analysis* (pp. 214–234). New York: Palgrave Macmillan.
- Firth, A. (2009). Doing not being a foreign language learner: English as a lingua franca in the workplace and (some) implications for SLA. *International Review of Applied Linguistics (IRAL)*, 47, 127–156.
- Firth, A., & Wagner, J. (1997). On discourse, communication, and (some) fundamental concepts in SLA research. *The Modern Language Journal*, 81, 285–300.
- Gardner, R., & Wagner, J. (Eds.). (2004). *Second language conversations*. London: Continuum.
- Garton, S. (2012). Speaking out of turn? Taking the initiative in teacher-fronted classroom interaction. *Classroom Discourse*, 3(1), 29–45.
- Hall, J. K., & Smotrova, T. (2013). Teacher self-talk: Interactional resource for managing instruction and eliciting empathy. *Journal of Pragmatics*, 47, 75–92.
- Hauser, E. (2013). Stability and change in one adult's second language English negation. *Language Learning*, 63(3), 463–498.
- Hellermann, J. (2008). *Social practices for language learning*. Clevedon: Multilingual Matters.
- Hosoda, Y. (2006). Repair and relevance of differential language expertise in second language conversations. *Applied Linguistics*, 27(1), 25–50.
- Huth, T., & Taleghani-Nikazm, C. (2006). How can insights from conversation analysis be directly applied to teaching L2 pragmatics? *Language Teaching Research*, 10, 53–79.
- Jakonen, T., & Morton, T. (2015). Epistemic search sequences in peer interaction in a content-based language classroom. *Applied Linguistics*, 36(1), 73–94.
- Johnson, K. E., & Golombek, P. R. (Eds.). (2011). *Research on second language teacher education*. New York: Routledge.
- Kasper, G., & Kim, Y. (2007). Handling sequentially inapposite responses. In Z. Hua, P. Seedhouse, L. Wei, & V. Cook (Eds.), *Language learning and teaching as social interaction* (pp. 22–41). London: Palgrave Macmillan.
- Kim, Y. (2012). Practices for initial recognitional reference and learning opportunities in conversation. *Journal of Pragmatics*, 44, 709–729.
- Ko, S. (2014). The nature of multiple responses to teachers' questions. *Applied Linguistics*, 35(1), 48–62.
- Koshik, I. (2010). Questions that convey information in teacher-student conferences. In A. Freed & S. Ehrlich (Eds.), *'Why do you ask?': The function of questions in institutional discourse* (pp. 159–186). New York: Oxford University Press.
- Lee, Y.-A. (2008). Yes-no questions in the third-turn position: Pedagogical discourse processes. *Discourse Processes*, 45(3), 237–262.
- Lee, Y.-A. (2010). Learning in the contingency of talk-and-interaction. *Text and Talk*, 30(4), 402–422.
- Lee, Y.-A. (2013). Descriptions of second language interaction: Toward descriptive adequacy. *The Modern Language Journal*, 97(4), 853–868.
- Markee, N. (2005). The organization of off-task talk in second language classrooms. In K. Richards & P. Seedhouse (Eds.), *Applying conversation analysis* (pp. 197–213). New York: Palgrave Macmillan.
- Markee, N. (2008). Toward a learning behavior tracking methodology for CA-for-SLA. *Applied Linguistics*, 29(3), 404–427.
- Mori, J. (2004). Negotiating sequential boundaries and learning opportunities: A case from a Japanese language classroom. *The Modern Language Journal*, 88(4), 536–550.
- Mortensen, K. (2011). Doing word explanation in interaction. In G. Pallotti & J. Wagner (Eds.), *L2 learning as social practice: Conversation-analytic perspectives* (pp. 135–162). Honolulu: University of Hawaii/National Foreign Language Resource Center.
- Nguyen, H. T. (2012). Social interaction and competence development: Learning the structural organization of a communicative practice. *Learning, Culture and Social Interaction*, 1, 127–142.

- Park, Y. (2014). The roles of third-turn repeats in two L2 classroom interactional contexts. *Applied Linguistics*, 35(2), 145–167.
- Pekarek Doehler, S. (2010). Conceptual changes and methodological challenges: On language and learning from a conversation analytic perspective on SLA. In P. Seedhouse, S. Walsh, & C. Jenks (Eds.), *Conceptualising learning in applied linguistics* (pp. 105–127). Basingstoke: Palgrave Macmillan.
- Reddington, E., & Waring, H. Z. (2015). Understanding the sequential resources for doing humor in the language classroom. *Humor: International Journal of Humor Research*, 28(1), 1–23.
- Reichert, T., & Liebscher, G. (2012). Positioning the expert: Word searches, expertise, and learning opportunities in peer interaction. *The Modern Language Journal*, 96(4), 599–609.
- Richards, K. (2006). Being the teacher: Identity and classroom conversation. *Applied Linguistics*, 27(1), 51–77.
- Schwartz, J. (1980). The negotiation for meaning: Repair in conversations between second language learners of English. In D. Larsen-Freeman (Ed.), *Discourse analysis in second language research* (pp. 138–153). Rowley: Newbury House.
- Seedhouse, P. (2004). *The interactional architecture of the language classroom: A conversation analysis perspective*. Malden: Blackwell.
- Seedhouse, P. (2008). Learning to talk the talk: Conversation analysis as a tool for induction of trainee teachers. In S. Garton & K. Richards (Eds.), *Professional discourse encounters in TESOL: Discourses of teachers in teaching* (pp. 42–57). New York: Palgrave Macmillan.
- Sert, O. (2013). ‘Epistemic status check’ as an interactional phenomenon in instructed learning settings. *Journal of Pragmatics*, 45, 13–28.
- Vygotsky, L. S. (1978). *Mind in society: The development of higher psychological processes*. Cambridge, MA: Harvard University Press.
- Walsh, S. (2006). *Investigating classroom discourse*. New York: Routledge.
- Walsh, S., & Li, L. (2013). Conversations as space for learning. *International Journal of Applied Linguistics*, 23(2), 247–266.
- Waring, H. Z. (2013a). ‘How was your weekend?’: Developing the interactional competence in managing routine inquiries. *Language Awareness*, 22(1), 1–16.
- Waring, H. Z. (2013b). Managing competing voices in the language classroom. *Discourse Processes*, 50(5), 316–338.
- Wong, J. (2002). ‘Applying’ conversation analysis in applied linguistics: Evaluating dialogue in English as a second language textbooks. *International Review of Applied Linguistics (IRAL)*, 40, 37–60.
- Wong, J. (2013). A coming of age of conversation analysis and applied linguistics. In T. Greer, D. Tatsuki, & C. Roever (Eds.), *Pragmatics and language learning* (Vol. 13, pp. 5–27). Honolulu: University of Hawaii/National Foreign Language Resource Center.
- Wong, J., & Waring, H. Z. (2010). *Conversation analysis and second language pedagogy*. New York: Routledge.



---

# Researching Body Movements and Interaction in Education

Xiaoting Li

---

## Abstract

It is widely acknowledged that talk is inextricably interwoven with body movements in everyday social interaction. Thus, it is important to take into account both talk and body movements deployed by participants when researching face-to-face interaction. Recent years have seen a growing interest in the study of body movements and interaction in educational settings. This chapter provides an overview of the early developments, major contributions, recent work in progress, and future research directions in the area of body movements in educational interaction. One commonality across these studies is that they provide detailed accounts of how body movements are consequential to the organization of actions in human interaction. Three theoretical approaches provide the foundation for the current research on body movements in educational interaction: the structural approach, conversation analysis, and microethnography. Utilizing these three approaches, recent research has explored the interactional function of body movements in education. Specifically, recent studies have examined the role of body movements in the display of emotions in educational interaction and multiactivity in education. Finally, some possible future research directions are discussed.

---

## Keywords

Body Movement • Educational Interaction • Interactional Function • Conversation Analysis

---

X. Li (✉)

East Asian Studies, University of Alberta, Edmonton, AB, Canada

e-mail: [xiaoting.li@ualberta.ca](mailto:xiaoting.li@ualberta.ca)

---

## Contents

Introduction .....	476
Early Developments .....	476
Major Contributions .....	478
Work in Progress .....	480
Problems and Difficulties .....	482
Future Directions for Research .....	483
Cross-References .....	484
Related Articles in the Encyclopedia of Language and Education .....	484
References .....	485

---

## Introduction

Human face-to-face interaction is by nature multimodal. People deploy a variety of semiotic resources such as syntax, prosody, body movements, and objects in the material world to form and organize actions in interaction. This chapter takes as its focus the multimodal and embodied nature of interaction in educational settings. Researching body movements and interaction in educational settings requires a serious treatment of body movement as an equally potentially relevant semiotic resource as language and a methodology to study its organization and relevance to educational interaction. This chapter discusses the main methodological approaches to the study of body movements and interaction in educational settings. First, I outline the structural approach, conversation analysis, and microethnography as three theoretical approaches that have laid the foundation for the current research on body movement and interaction in education. Second, recent methodological approaches to body movement in educational interaction are discussed. They are the interactional approach, conversation analytical approach, and multimodal analysis. The interactional approach examines how learning takes place in the interactive coordination of interactants in accomplishing joint activities and tasks. Studies in conversation analytical approach focus on how learners organize their turns and actions in a sequential and locally contingent way in and through which learning transpires. The multimodal approach takes as their central question the interplay of language, body movement, and artifacts in the surround in building actions and activities in educational interaction. Finally, the emerging research, challenges and future directions in researching body movements and interaction in education are discussed.

---

## Early Developments

The research on body movements in social interaction has emerged in the past several decades (Goodwin 1979; McNeill 1992; Mondada 2014). Early research on body movements in interaction has been mainly conducted from three methodological approaches: the structural approach (Context Analysis) (Schefflen 1964),

conversation analysis (Schegloff 1984), and microethnography (Erickson and Shultz 1982). Each of these is discussed below.

The structural approach to bodily movements in interaction derives from Ray Birdwhistell's work (1952) in kinesics and Albert Scheflen's research (1964) on the structural units of bodily movements in psychotherapy interaction. It mainly focuses on the description of the organizational orderliness of body movements and their relatedness to the structural units in face-to-face interaction. For example, the organization of gaze, gesture, posture, body orientation, and space of interactants is considered related to and coordinated with speech units and speaking turns in interaction (Kendon 1972). The structural approach has been applied to the study of interaction in educational settings. For instance, it has been documented that students perform certain patterns of leftward and downward body movements at the boundaries of their utterances (De Long 1974). The structural approach provides detailed accounts of the structural units of body movements and how they contribute to the construction of structural units in interaction.

The second approach to body movements in interaction is conversation analysis (CA). Although early CA work mainly focuses on audio recordings of conversation (Schegloff and Sacks 1973), video-based CA research started to appear in the 1980s due to the development of video technology (e.g., Schegloff 1984). CA is interested in not only the organizational structure of body movements but also how the structure shapes the emerging course of talk in interaction. For example, iconic gestures regularly precede the lexical components they depict, which allows them to be used by interactants to project and predict the incipient turn elements (Schegloff 1984). Due to its focus on the relevance of body movements to the temporally unfolding interaction, some recent research on students and teachers' body movements in classroom interaction also adopts the CA methodology (Mortensen 2008; Szymanski 1999).

The third approach to body movements and interaction in education is microethnography. This approach focuses on how courses of actions are co-constructed and socially and culturally organized in particular situational settings (Erickson and Shultz 1982). Two thrusts in microethnography are particularly relevant to researching body movements and interaction in educational settings. One is the attention to not only verbal but also nonverbal behaviors of the participants in situated contexts (McDermott and Gospodinoff 1979; Shultz and Florio 1979). The other is the emphasis on the coordination and influence between speakers and recipients in the co-construction of their identities in particular sociocultural contexts (Erickson and Shultz 1982). Microethnographic studies have shown that teachers use a series of verbal and nonverbal behaviors to signal the change of context in classroom activities (Shultz and Florio 1979) and that different spatial-orientational organizations of the students and teacher's bodies constitute different participation frameworks that contextualize different phases in classroom activities (McDermott and Gospodinoff 1979).

Despite their analytic and methodological differences, the three previous approaches to body movements in interaction share some commonalities. First, those approaches all use recordings of naturally occurring interaction as their

primary data. Second, the research methods are qualitative and observational and are not concerned with what is not observed or observable in interaction, such as interactants' beliefs or intentions. This psychological aspect of the use of gesture has been thoroughly investigated by McNeil and his colleagues at the University of Chicago (e.g., McNeill 1992).

As the main methodologies for the earlier study of body movements and interaction, the previous three approaches established the empirical evidence that talk and body co-occur and jointly build naturally occurring interaction. They inform current work on face-to-face interaction in general and on body movements in educational interaction in particular.

---

## Major Contributions

Embodiment (the involvement of the body) is an inherent feature of (language) learning. Despite the acknowledgement of the integration of language, gesture, and objects in the communicative context and learning environment, researching on body movements and (language) learning in educational setting is still an emerging field of study. The earlier approaches to body movements in naturally occurring interaction provide important concepts and methods for the study of body movements in educational interaction. The emerging field of multimodal analysis also offers a new perspective to the research on body movements in education.

The interactional approach to body movements in educational has been developed in Europe (e.g., Mondada and Pekarek Doehler 2004) and North America (e.g., Hall 1993) since the 1990s. This approach considers learning as derived from learner's interaction and coordination with others in their participation in joint activities and task accomplishment (Ford 1999; Mondada and Pekarek Doehler 2004). In jointly accomplishing tasks, students usually use a variety of resources such as talk, body movements, and objects in the surround. John Hellermann and his collaborators offered detailed accounts of how learners of English collaboratively and interactively enter into and exit from serial dyadic interaction tasks (Hellermann and Cole 2008). They have shown that students may deploy posture shift, gaze (at others), and (smiling) facial expressions to display disengagement from a task. Ford (1999) reports that students mobilize a variety of semiotic resources including gaze and postural shifts to display their shifts of attention and the transformation of participation framework. The interactional approach provides us with a useful perspective and tool to study the interactional and pedagogical significance of body movements for learning in situated interaction.

CA is another important approach in the study of body movements in education. Within the CA framework, turn-taking and repair organization are two fundamental sequential organizations of talk-in-interaction. While turn-taking organization in classroom has been heavily researched (e.g., Sinclair and Coulthard 1975), the body movements involved in turn allocation in classroom has only been the focus of relatively recent attention. Students and teachers deploy not only vocal resources but also body movements to allocate turns in classroom interaction. For example,

students routinely use hand raising to request the floor (Sahlström 2002) and gaze toward the teacher to display willingness to be selected as a next speaker (Mortensen 2008) in classroom interaction. Teachers may deploy head nods and pointing gesture with or without the student's name to allocate turns to students (Kääntä 2010). In small-group interactions, first language (L1) and second language (L2) speakers are observed to produce a turn through both talk and body movements, though with different purposes. Occasioned by small-group projects, L2 speakers may complete an utterance through gesture or other types of body movements (which is called "embodied completion" by Olsher 2004). L1 speakers may also use bodily movements to complete the action initiated in a turn in their interaction with L2 speakers (Mori and Hayashi 2006). However, Mori and Hayashi highlighted that L1 speakers' "embodied completion" has different implication from that of the L2 speakers; it not only facilitates comprehension but also produces an opportunity for the L2 speakers to learn more advanced linguistic forms.

Another sequential organization studied extensively in CA classroom research along with turn taking is repair organization. Teachers and students initiate and perform repairs by using various resources including lexico-syntax, prosody, and embodied actions (Hall 2007; Kääntä 2010). Teachers may use various embodied actions such as cutoff body movements, motionless gaze, and body orientation or diverging gaze trajectories and body movements toward teaching materials or class to project incipient repair initiation (Kääntä 2010). Students may deploy body movements coupled with talk to do repairs. For example, in natural conversation among English as a second language (ESL) speakers, Olsher (2008) documented that they sometimes used repeats accompanied (and arguably enhanced) by gesture to perform repairs. The gesturally enhanced repeats demonstrated the speaker's orientation to problems of both hearing and understanding. Seo (2011) also described that tutors used more complex gesture and material objects together with verbal repeats to perform repair in ESL tutoring. The "repeat plus embodied action" in these studies was shown to be an effective repair strategy with pedagogical implications. Recipients regularly displayed attention to and engagement with the gesturally enhanced repeats. Through this special attention, the semantics of the repeated lexical item was made salient to the learner (Olsher 2008, p. 122). The gesture also served as locally relevant resources in resolving the problems of understanding and achieving intersubjectivity; thus its usage in repair demonstrated that L2 learning was closely related to L2 interaction (Seo 2011).

The copresence of interactants and their body movements is also of significance to the organization of sequences in classroom interaction, for example, to the beginning and closing of tutoring session (Belhiah 2009), to the (re-)engagement and disengagement of turn-by-turn talk in students group work (Hellermann and Cole 2008; Szymanski 1999), and to the negotiation of sequence boundaries for learning opportunities in language classroom (Mori 2004). Students working by themselves in a group setting may stop working and produce postural shift (e.g., leaning away from the table) to display their availability and set the stage for re-engaging talk in activity (Szymanski 1999). Postural shift, gaze, and facial expressions may also be used to display disengagement from the activity

(Hellermann and Cole 2008). Students' gaze shift and change of body orientation are used to mark the boundary of side sequences (e.g., repair and word search) and that of the main assigned task (Mori 2004). The visibility of the students' bodies is essential for their regulating the groups' activities. The body serves as a resource, among others, that students use in managing the (re-)engagement of talk and different activities in group work interaction.

The third approach to body movements and interaction in educational settings is to consider the body as a semiotic system in the "ecology of sign systems" (Goodwin 2003). This approach has also been called multimodal analysis and embodied interaction (Sidnell and Stivers 2005), and it has emerged in the last few years, especially the last decade. It explores how talk and action are constructed by the coordination of resources of different vocal and visual modalities (including lexico-syntax, prosody, gaze, facial expressions, gesture, posture, spatial and orientational arrangement of the interactants, etc.) as well as aspects in the material world (Streeck et al. 2011). CA-informed interactional linguists also contribute to this multimodal inquiry through exploring the working together of vocal and bodily visual modalities (e.g., Selting 2013). Although this type of research has been conducted since the 1970s by the Goodwins (e.g., Goodwin 1979), as far as I know, the name of "multimodal interaction" was first explicitly put forward in Sidnell and Stivers (2005). Multimodal analysis furnishes us with a useful tool for researching body movements and the multimodal construction of interaction in education. Specifically, body movements are used together with talk and objects in the material surround to perform a range of actions in teacher-student and student-student interaction. Applying the multimodal method, Goodwin (2003) explored the interaction between senior archaeologists and graduate students and demonstrated that the arrangements of interactants' bodies were of special significance to the process of education and apprenticeship. The positioning, orientation, and movement of senior and young archaeologists' bodies in relation to each other were important resources to understand and build actions in concert with each other and to recognize relevant structures. Thus, he argued that the students' professional competence was formed in and through the embodied practices and interaction with senior archaeologists in the field. Through the study of body movements together with other multimodal resources (i.e., multimodal analysis) and within situated activities, Goodwin demonstrated the ways in which the body is implicated in the organization of language and interaction in and through which learning is accomplished.

---

## Work in Progress

There has been a growing interest in embodied interaction in education in the past decade with a number of newly developed research projects and activities in this field. There are two main areas of in-progress work: body movements as embodied

displays of emotions or affective stances in educational interaction and the role of bodily movements in multiactivity in education.

Although emotion is an important aspect of language use and human interaction, the study of emotion in interaction from an interactional perspective is a rather recent endeavor. Elizabeth Couper-Kuhlen and Margret Selting co-directed a research project on emotive involvement in conversational storytelling from an interactional linguistic perspective as part of a larger research initiative on languages of emotion at the Freie Universität Berlin since 2008, and they have reported their research findings in multiple publications (e.g., Selting 2013, among others). For example, Selting (2013) reported that complaint story recipients, in addition to or instead of producing assessments or response cries, expressed their affiliation with the teller's affect by offering a complaint story of their own. This interactional linguistic approach to emotion contributes to our understanding of how people use language and the body to construct and display emotions and affects in everyday interaction. Display of emotions is also of great significance and implications to interaction in educational settings. Students may display different emotions to achieve particular purposes in their interaction with the teacher. To make their emotions accessible, students employ a constellation of vocal and visual resources including lexicosyntactic, prosodic, and bodily resources. For example, Cekaite (2012) argued that students use gesture, body posture, and body positioning to display noncompliance to teacher's directives. Teachers may use embodied actions to arrange the students' body into an interactionally appropriate learning posture in response to student's embodied resistance. Cekaite's study on the students' embodied displays of emotions in classroom interaction exemplifies the first area in which more work is in progress.

The second area where new research is emerging is on body movements as resources in managing multiactivity in educational interaction. Doing more than one thing at the same time is pervasive in not only everyday social interaction but also educational interaction. For instance, in a lab, teachers may be explaining knowledge revealed in the process of an experiment to students while conducting the experiment themselves. The newly released book volume on multiactivity in social interaction (Haddington et al. 2014) presented this intricate and complex organization of multiactivity in different types of social interaction and outlined the important concepts in the study of multiactivity in interaction. In this volume, Mondada (2014) demonstrates the complex ways in which the multiple activities (i.e., a surgical operation at the operation theater and its demonstration for medical professional trainees) are interactively organized and intertwined with one another based on their temporal relations. Also, each activity is accomplished through the use of multimodal resources such as talk and body movements. The fine-grained analysis of the locally relevant multimodal resources in the organization of the multiple activities in educational setting exemplified by Mondada (2014) is the other area where work is still in progress.

## Problems and Difficulties

The overview of recent research on body movements and interaction in educational settings has shown that the multimodal approach to educational interaction is gaining vast popularity. Yet a number of challenges remain. One of the main difficulties is the lack of consistent and concrete methods in multimodal analysis. Many are aware of its significance, but not all have systematic understanding of how to conduct multimodal research. This difficulty is largely due to two factors: the broad use of the term “multimodal(ity)” and the wide variety of modalities involved in face-to-face interaction.

First, the notion of multimodality has been applied to many other disciplines (such as multimodal input in computer science) as well as other subfields of linguistics before or concurrent with the use of multimodal analysis in interaction studies. For example, in linguistic research, “multimodal” is used in multimodal discourse analysis (Kress and van Leeuwen 2001) which is built on Halliday’s social semiotic approach to language (Halliday 1978). “Multimodal” is also seen in multimodal communication (Norris 2004) which studies not only the verbal aspects but also other artifacts, objects, and the surround involved in daily communication. Some of the researchers in multimodal communication draw on Scollon’s (1998) study of mediated discourse analysis. “Multimodal” is also used in the term multimodal corpus (or corpora) which refers to the representation of data in the form of textual, audio, visual (images and videos), and discourse-functional information (Gu 2006). The multimodal analysis in interaction studies introduced in the previous sections approaches human interaction from a different angle. It differs from other “multimodal” approaches due to its detailed microanalytical focus on the formation of sequences of actions and the relevant vocal and visual behaviors involved in their formation (Streeck et al. 2011). The use of the notion “multimodal” in each type of study differs from the others and brings a distinctive set of methods with them. Thus, it is not surprising that there is a lack of consistent methodology in the study of multimodality in interaction.

Second, the number and variety of modalities involved in interaction form another difficulty for the multimodal analysis of interaction. Sometimes, there can be a number of practices of different modalities that are relevant to the formation and interpretation of actions in interaction (Selting 2013; Stivers and Sidnell 2005). For example, when a student offers her/his answer to a question asked by a teacher in a classroom (not involving the use of sign languages), she/he would use resources of the vocal modality (including lexico-syntactic construction and prosody), the visual modality (such as gaze, gesture, posture, proxemics, spatial-orientational position of her/his body in relation to those of others in the classroom, and objects in the surround, etc.), and the pragmatic modality (such as the particular task at hand, the sequential position of the student’s utterance in the larger sequence of actions) (Ford 1999; Mondada and Pekarek Doehler 2004). In different interactions, different ensembles of the multimodal resources may be deployed and be made relevant (e.g., Goodwin 1979; Schegloff 1984). In order to conduct in-depth analysis of all relevant multimodal resources involved in a particular interaction, multimodal



analysts ideally shall have training in multiple fields such as morphology, syntax, phonetics/prosody, pragmatics, gesture studies, and interaction studies, among others. Otherwise, a multimodal analysis study may not be “multimodal” in its real sense in that it would have more substantial discussions on particular modalities while less or no discussion on others. The sheer number and variety of modalities that emerge in our daily interaction pose a great challenge to the multimodal analysts.

Finally, the research on body movements and interaction is of particular relevance to the education of deaf students. Sociocultural studies of sign language and deaf education have eloquently shown the importance and challenges of promoting bilingual education involving both a signed and a spoken/written language for deaf children within the school setting (Plaza-Pust and Morales-Lopez 2008). However, compared to the heightened awareness of the importance of sign language in deaf education, our understanding of the relationship between signed and written lexical representations is still rather limited (Carlson et al. 2010). Thus, research on educational linguistics in sign-text bilingualism is still much needed.

---

## Future Directions for Research

Due to the growing interest in multimodality and embodied interaction, body movements and interaction in education will continue to be a popular research area. However, some important research questions have not been fully addressed in the previous studies. These unresolved questions include the divergence of multimodal resources, the role of touch/physical contact in educational interaction, body movements in computer-mediated communication in education, and body movements in educational interaction from a cross-cultural perspective. They together form the future research directions.

First, previous studies on body movements as well as other types of multimodal resources in educational settings have mainly focused on the convergence of these resources, that is, how they work together and mutually elaborate each other in the construction of actions in interaction (Streeck et al. 2011). We still know very little about if body movements diverge with other multimodal resources such as lexico-syntax and prosody. How do interactants orient to the divergence? The implications of the divergence in educational interaction still await future study.

Second, various types of body movements (such as gaze, gesture, posture, body orientation, body position, facial expression) and their interactional functions have been investigated in educational settings (Ford 1999; Mondada and Pekarek Doehler 2004; Szymanski 1999). Surprisingly little research has been conducted on (interpersonal) touch in educational interaction. Touch and physical contact have been shown to be an important practice to display emotions and intimacy in everyday interaction (Field 2001). What is the role of touch in educational interaction? It is hoped that future research could provide answers to these questions.

Third, with the growth of online and distance education, computer-mediated communication (CMC) has become a popular research area in education (for further

explanations on CMC and its research methods in education). Although CMC differs from the traditional face-to-face instruction in many aspects, it is also an important form of interaction in education. As the interaction between the instructor and the students is mediated through a network of computers in CMC, the participants' body movement may (or may not) play a different role from that in face-to-face educational interaction (Witt and Wheelless 1999). Rapid developments in CMC technology and the inquiry into the role of the human body in CMC teaching and learning will offer rich insights into research methodology on body movements in educational interaction as well as educational practices.

Finally, in light of the diversity of languages and cultures in the world, we still know very little about the role of body movements in educational interaction in other cultures and languages relative to the heavily researched Indo-European languages (e.g., Ford 1999; Mondada and Pekarek Doehler 2004; Mortensen 2008). Chen (2013) observes Chinese as Second Language (CSL) classrooms with learners from 12 countries and argues that the use of gestures in Chinese tone instruction enhances students' communication performance. Belhiah (2009) reports that when Korean students communicate with their American tutors in English, they exhibit the same uses of gaze and other body movements as those among native speakers of American English, but different from those among Korean speakers. This type of research on body movements and classroom interaction in less-studied languages is still needed.

Researching body movements and interaction in education is an interdisciplinary undertaking that draws on imports from multiple interrelated disciplines such as linguistics, sociology (ethnomethodology, conversation analysis), gesture studies, communication studies, psychology, etc. The research perspectives may vary, depending on the (inter)disciplinary background of researchers. However, one question that the research on body movements in educational interaction should address is if and how the body movements under investigation are relevant to the interactants themselves (participant's orientation) rather than us analysts.

---

## Cross-References

- ▶ [Conversation Analytic Approaches to Language and Education](#)
- ▶ [Interactional Approaches to the Study of Classroom Discourse and Student Learning](#)
- ▶ [Microethnography in the Classroom](#)
- ▶ [Researching Multimodality in Language and Education](#)

---

## Related Articles in the Encyclopedia of Language and Education

Judith Green and Janet Joo: [Classroom Interaction, Situated Learning](#). In Volume: Discourse and Education

## References

- Belhiah, H. (2009). Tutoring as an embodied activity: How speech, gaze and body orientation are coordinated to conduct ESL tutorial business. *Journal of Pragmatics*, 41, 829–841.
- Birdwhistell, R. (1952). *Introduction to kinesics: An annotation system for analysis of body motion and gesture*. Louisville: University of Louisville.
- Carlson, M. L., Morford, J. P., Shaffer, B., & Wilcox, P. P. (2010). The educational linguistics of bilingual deaf education. In F. M. Hult (Ed.), *Directions and prospects for educational linguistics* (pp. 99–115). New York: Springer.
- Cekaite, A. (2012). Affective stances in teacher-novice student interactions: Language, embodiment, and willingness to learn in a Swedish primary classroom. *Language in Society*, 41, 641–670.
- Chen, C.-M. (2013). Gestures as tone markers in multilingual communication. In I. Kecskes (Ed.), *Research in Chinese as a second language* (pp. 143–168). Berlin: De Gruyter Mouton.
- De Long, A. (1974). Kinesic signals at utterance boundaries in preschool children. *Semiotica*, 11(1), 43–73.
- Erickson, F., & Shultz, J. (1982). *The counselor as gatekeeper: Social interaction in interviews*. New York: Academic.
- Field, T. (2001). *Touch*. Cambridge, MA: MIT Press.
- Ford, C. E. (1999). Collaborative construction of task activity: Coordinating multiple resources in a high school physics lab. *Research on Language and Social Interaction*, 32(4), 369–408.
- Goodwin, C. (1979). The interactive construction of a sentence in natural conversation. In G. Psathas (Ed.), *Everyday language: Studies in ethnomethodology* (pp. 97–121). New York: Irvington Publishers.
- Goodwin, C. (2003). The body in action. In J. Coupland & R. Gwyn (Eds.), *Discourse, the body and identity* (pp. 19–42). New York: Palgrave/Macmillan.
- Gu, Y. G. (2006). Multimodal text analysis: A corpus linguistic approach to situated discourse. *Text and Talk*, 26(2), 127–167.
- Hall, J. K. (1993). The role of oral practices in the accomplishment of our everyday lives: The sociocultural dimension of interaction with implications for the learning of another language. *Applied Linguistics*, 14, 145–167.
- Hall, J. K. (2007). Redressing the roles of correction and repair in research on second and foreign language learning. *The Modern Language Journal*, 91(4), 511–526.
- Halliday, M. A. K. (1978). *Language as social semiotic: The social interpretation of language and meaning*. London: Arnold.
- Hellermann, J., & Cole, E. (2008). Practices for social interaction in language learning classrooms: Disengagement from dyadic task interaction. *Applied Linguistics*, 30, 186–215.
- Kääntä, L. (2010). *Teacher turn-allocation and repair practices in classroom interaction: A multimodal perspective*. Unpublished doctoral dissertation. University of Jyväskylä, Jyväskylä.
- Kendon, A. (1972). Some relationships between body motion and speech. In A. Seigman & B. Pope (Eds.), *Studies in dyadic communication* (pp. 177–216). New York: Pergamon Press.
- Kress, G., & Van Leeuwen, T. (2001). *Multimodal discourse: The modes and media of contemporary communication*. London: Arnold.
- McDermott, R. P., & Gospodinoff, K. (1979). Social contexts for ethnic borders and school failure. In A. Wolfgang (Ed.), *Nonverbal behavior: Applications and cultural implications* (pp. 175–196). New York: Academic.
- McNeill, D. (1992). *Hand and mind: What gestures reveal about thought*. Chicago: University of Chicago Press.
- Mondada, L. (2014). The temporal orders of multiactivity: Operating and demonstrating in the surgical theatre. In P. Haddington, T. Keisanen, L. Mondada, & M. Nevile (Eds.), *Multiactivity in social interaction: Beyond multitasking* (pp. 33–75). Amsterdam: John Benjamins.

- Mondada, L., & Pekarek Doehler, S. (2004). Second language acquisition as situated practice: Task accomplishment in the French second language classroom. *The Modern Language Journal*, 88(4), 501–5181.
- Mori, J. (2004). Negotiating sequential boundaries and learning opportunities: A case from a Japanese language classroom. *The Modern Language Journal*, 88(4), 536–550.
- Mori, J., & Hayashi, M. (2006). The achievement of intersubjectivity through embodied completions: A study of interactions between first and second language speakers. *Applied Linguistics*, 27(2), 195–219.
- Mortensen, K. (2008). Selecting next-speaker in the second language classroom: How to find a willing next-speaker in planned activities. *Journal of Applied Linguistics*, 5(1), 55–79.
- Norris, S. (2004). *Analyzing multimodal interaction: A methodological framework*. London: Routledge.
- Olsher, D. (2004). Talk and gesture: The embodied completion of sequential actions in spoken interaction. In R. Gardner & J. Wagner (Eds.), *Second language conversations* (pp. 221–245). London: Continuum.
- Olsher, D. (2008). Gesturally enhanced repeats in the repair turn: Communication strategy or cognitive language-learning tool? In S. G. McCafferty & G. Stam (Eds.), *Gesture: Second language acquisition and classroom research* (pp. 109–130). Oxford: Routledge.
- Plaza-Pust, C., & Morales-Lopez, E. (2008). Sign bilingualism: Language development, interaction, and maintenance in sign language contact situations. In C. Plaza-Pust & E. Morales-López (Eds.), *Sign bilingualism: Language development, interaction, and maintenance in sign language contact situations* (pp. 333–379). Amsterdam: John Benjamins.
- Sahlström, F. (2002). The interactional organization of hand raising in classroom interaction. *Journal of Classroom Interaction*, 37(2), 47–57.
- Schefflen, A. E. (1964). The significance of posture in communication systems. *Psychiatry*, 27(4), 316–331.
- Schegloff, E. A. (1984). On some gestures' relation to talk. In M. Atkinson & J. Heritage (Eds.), *Structures of social action: Studies in conversation analysis* (pp. 266–296). Cambridge: Cambridge University Press.
- Schegloff, E. A., & Sacks, H. (1973). Opening up closings. *Semiotica*, 8(4), 289–327.
- Scollon, R. (1998). *Mediated discourse as social interaction*. London: Longman.
- Selting, M. (2013). Verbal, vocal, and visual practices in conversational interaction. In C. Müller, E. Fricke, A. Cienki, & D. McNeill (Eds.), *Body-language-communication: An international handbook on multimodality in human interaction* (Vol. 1, pp. 589–609). Berlin: de Gruyter.
- Seo, M.-S. (2011). Talk, body, and material objects as coordinated interactional resources in repair activities in one-on-one ESL tutoring. In G. Pallotti & J. Wagner (Eds.), *L2 learning as social practice: Conversation-analytic perspectives* (pp. 107–134). Honolulu: NFLRC, University of Hawaii.
- Shultz, J., & Florio, S. (1979). Stop and freeze: The negotiation of social and political space in a kindergarten/first grade classroom. *Anthropology and Education Quarterly*, 10, 166–181.
- Sinclair, J., & Coulthard, M. (1975). *Towards an analysis of discourse*. Oxford: Oxford University Press.
- Stivers, T., & Sidnell, J. (2005). Introduction: Multimodal interaction. *Semiotica*, 156(1/4), 1–20.
- Streeck, J., Goodwin, C., & LeBaron, C. (2011). Embodied interaction in the material world: An introduction. In C. Goodwin & C. LeBaron (Eds.), *Embodied interaction: Language and body in the material world* (pp. 1–26). Cambridge: Cambridge University Press.
- Szymanski, M. H. (1999). Re-engaging and dis-engaging talk in activity. *Language in Society*, 28, 1–23.
- Witt, P. L., & Wheelless, L. R. (1999). Nonverbal communication expectancies about teachers and enrollment behavior in distance learning. *Communication Education*, 48(2), 149–154.

---

# Code-Switching in the Classroom: Research Paradigms and Approaches

Angel M. Y. Lin

---

## Abstract

Classroom code-switching refers to the alternating use of more than one linguistic code in the classroom by any of the classroom participants. This chapter provides a review of the historical development of the different research paradigms and approaches adopted in various studies. The difficulties and problems faced by this field of studies and critical reflections on how this field might move forward in the future are discussed.

---

## Keywords

Classroom Code-switching • Disciplinary Plurilinguals • Translanguaging • Discourse Formats • Mode-switching

## Contents

Introduction .....	488
Early Developments .....	489
Early Studies on Relative Amounts of L1/L2 Use Across Activity Types and Settings ...	489
Early Studies on Functional Distribution of L1/L2 Use .....	490
Major Contributions .....	491
Work in Progress .....	494
Problems and Difficulties .....	495
Lack of Design-Interventionst Studies .....	495
Lack of “Disciplinary Plurilinguals” .....	496
Scarcity of Theory-Driven Research Questions .....	496
Lack of Variety in Research Designs .....	496
Future Directions for Research .....	497
Cross-References .....	499
Related Articles in the Encyclopedia of Language and Education .....	499
References .....	499

---

A.M.Y. Lin (✉)

Faculty of Education, The University of Hong Kong, Hong Kong, China

e-mail: [yeonmia@gmail.com](mailto:yeonmia@gmail.com); [angellin@hku.hk](mailto:angellin@hku.hk)

## Introduction

Classroom code-switching refers to the alternating use of more than one linguistic code in the classroom by any of the classroom participants (e.g., teacher, students, teacher aide). In this discussion, both code-mixing (intraclausal/sentential alternation) and code-switching (alternation at the interclausal/sentential level) are referred to by the umbrella term, code-switching, as this is also the general practice in many classroom code-switching studies. However, whether we refer to it as code-mixing, switching, or alternation, this *code-X* terminology begs the question of whether language should, in the first place, be conceptualized as discrete “codes” with stable boundaries. The term, “code,” in linguistics has been borrowed from information theory, and Alvarez-Caccamo (2001) delineates the original and derived usage of the term as follows:

In information theory, a code is a mechanism to pair two sets of signals in non-ambiguous, reversible, and context-free ways. . . . Inferential views of communication propose that most understanding depends on the particulars of the relationship between literal contents and contexts. . . . this has led to a disabling of the applicability of the “code model” to human communication (pp. 23–24).

Recent years have further witnessed increasingly poststructuralist views on language, seeing language not as static “codes” with solid boundaries but rather, as fluid resources in meaning-making practices (Pennycook 2010). These views are captured in the recent use of the terms “code-meshing” (Canagarajah 2011) and “translanguaging” (Creese and Blackledge 2010; García 2009), which seek to take away the “markedness” of the linguistic phenomenon that is traditionally called “code-switching” and reconceptualize it as a social practice that is part and parcel of everyday social life. Lewis et al. (2012) aptly summarized their analysis of the historical development of the term, translanguaging:

A plethora of similar terms (e.g., metrolingualism, polylinguaging, polylingual language, heteroglossia, codemeshing, translingual practice, flexible bilingualism, multilinguaging, and hybrid language practices) makes this extension of translanguaging appear in need of focused explication and more precise definition. Such varied terms are competitive with translanguaging for academic usage and acceptance (p. 649).

Such a vast range of studies presents difficulties in any attempt to achieve a comprehensive review in the limited space of an article. This chapter aims at providing a review of the historical development of the different research paradigms and approaches adopted in various studies. Then I analyze the difficulties and problems faced by this field of studies and share some of my own critical reflections on how this field might move forward in the future.

## Early Developments

While classroom code-switching studies have been diverse, the often-quoted early studies have been conducted in North American settings in two main kinds of contexts: (1) second language contexts (e.g., English as a second language [ESL] classroom) and (2) bilingual education classrooms. Quantitative and functional coding analysis was often used. The research questions usually focused on two aspects: (1) the relative quantities of first language (L1) and second language (L2) use in different activity settings and (2) the functional distribution of L1 and L2. Below is a review of the major types of research methods used in some early studies.

### Early Studies on Relative Amounts of L1/L2 Use Across Activity Types and Settings

This type of research has largely been conducted in North American settings with children in bilingual education programs (e.g., Wong-Fillmore 1980). The main emphasis of such work is to investigate whether linguistic minority children's L1 (e.g., Spanish, Chinese) and the wider, societal language (English) are given equal emphasis by calculating the relative quantities of use in the classroom (in terms of the number of utterances in each code or the time spent on it). Data for such studies is typically collected through class visits and observations with subsequent analysis of field notes and audio/videotapes. For instance, Wong-Fillmore (1980) found a range of L1 use depending on the degree of individualization in teacher-student interaction. In a Cantonese-English bilingual program, the teacher spoke the least L1 (8% of all her utterances) and the most L2 (92%) during whole-class instruction. She spoke more L1 (28%) during interactions with individual students in seatwork. The child chosen for observation, on the other hand, spoke much more L1 (79%) in seatwork than during teacher-directed whole-class instruction (4% L1). This study suggests the preference for the use of L1 in less formal, more intimate participant structures. In another study (Frohlich et al. 1985) on the communicative orientation of L2 classrooms in four different programs in Canada, teacher talk in all four programs was found to reflect very high L2 use (96%). However, the researchers noted that students generally used the target language only while the teacher exercised control over classroom activities. During seatwork, most interaction occurred in the students' L1. Again, this work highlighted students' strong preference for using L1.

While the interactive sociolinguistic notion of "participant structure" (Goffman 1974; Heller and Martin-Jones 2001) was not used in these initial studies, early researchers relied instead on the related notion of activity type or setting (e.g., individual seatwork, group work, whole-class instruction) as an important factor affecting the relative amounts of L1/L2 use in both studies mentioned above. In contrast, other work used functional coding systems in their analysis to develop categories of functions of L1 use.

## Early Studies on Functional Distribution of L1/L2 Use

Many of the functional studies were conducted in bilingual content classrooms in the USA and only a few in second and foreign language classrooms. In these studies, classroom utterances were usually coded by the observer with a functional coding system (e.g., Flanders 1970) yielding frequency counts of distribution of L1 and L2 across different functional categories. For instance, in a study of five kindergartens in Spanish bilingual programs using an adaptation of Flanders' Multiple Coding System, Legarreta (1977) reported on the functional distribution of Spanish (L1) and English (L2) in two different program models: the concurrent translation (CT) and alternative days (AD). She found that the AD model generated an equal distribution of Spanish and English by teachers and children overall, with more Spanish used for "warming" and "directing" functions and English as the primary choice for disciplining children. However, in the CT model, instead of using the L1 (Spanish) of the majority of the pupils to express solidarity (warming, accepting, amplifying), the teachers and aides predominantly used English for these functions.

In another study, Milk (1981) coded teacher talk in a 12th grade civic education lesson according to eight basic pedagogical functions (e.g., informative, directive, humor-expressive) based on Sinclair and Coulthard (1975). English (L2) was found to dominate the teacher's directives (92%) and meta-statements (63%), while there was a greater balance between L1 and L2 in other functions (e.g., elicitation, expressive, reply, informative). In addition, Milk described the skillful manner in which the bilingual teacher employed extensive switching between Spanish and English to create humor, both as a means of social control (via the creation of a sense of solidarity) and as a way to arouse students' interest. Guthrie (1984) used similar research methods in a study of an ESL lesson attended by 11 first-grade Cantonese-American students. Two types of lessons were analyzed: reading in English with a Cantonese-English bilingual teacher and oral language with an English monolingual teacher. Guthrie found that interactions of the English monolingual teacher with the basic-English-proficiency students in the oral lessons had many conversational acts such as "attention-getters," indicating a certain lack of teacher control and a frequent loss of student attention. In contrast, while the bilingual teacher used Cantonese (L1 of the students) very rarely (less than 7% on average) in the English reading lessons, when she did it was for a distinct reason. She told the researcher that she tried to avoid using Cantonese during these lessons and was surprised to find she had used L1 as much as she had. The functions of L1 use reported by Guthrie can be summarized as: (1) to act as a "we-code" for solidarity, (2) to clarify or check for understanding, and (3) to contrast variable meanings in L1 and L2 and to anticipate likely sources of confusion for students. While the functional coding approach dominated early work, in some studies (e.g., Milk 1981; Guthrie 1984) preliminary use of ethnographic interviews and interactional sociolinguistic methods were incorporated, a trend which continued in later work.



## Major Contributions

Many early studies seemed to have worked with the assumption that functional categories were stable, valid categories of classroom speech and that analysts could reliably assign utterances to each category. Yet the functional coding approach in early studies in fact involved a lot of sociolinguistic interpretive work on the part of the coder. This interpretive work was, however, not made explicit but taken for granted in the form of final frequency counts of L1 and L2 distributed across different functional categories (e.g., Legarreta 1977; Milk 1981). Later studies (e.g., Adendorff 1993; Heller 1999; Martin 1996, 2003; Martin-Jones 1995, Heller and Martin-Jones 2001; Merritt et al. 1992; Polio and Duff 1994; Simon 2001; Üstünel and Seedhouse 2005) have, to varying degrees, dispensed with a priori lists of functional categories and drawn on research approaches from interactional sociolinguistics and ethnography of communication (e.g., Goffman 1974; Gumperz 1984); conversation analysis (e.g., Sacks 1965/1992); interpretive research paradigms; critical social theory (e.g., Bourdieu and Passeron 1977); and critical research paradigms to study classroom code-switching (e.g., Heller and Martin-Jones 2001; Li 2011).

Just as interactional sociolinguistics (IS) and ethnography of communication (EC) provide the most useful analytic tools for researching and understanding code-switching in different settings in society, their concepts and methods have been drawn upon in classroom studies on code-switching. For instance, the most frequently and fruitfully used ones are code-switching as contextualization cues (Gumperz 1984) to signal a shift in the frame or footing (Goffman 1974) of the current interaction (e.g., Adendorff 1993). Frame or footing is the definition of what is happening and it is constantly being negotiated, proposed (signaled), and redefined by the speakers engaged in interaction. Different frames or footings that are being evoked (or signaled and proposed by a speaker) involve the simultaneous negotiation of different role-relationships and the associated sets of rights/obligations. Lin's studies (1990, 1996), for instance, drew on these interactional sociolinguistic analytic concepts to analyze code-switching in both English language lessons and content lessons in Hong Kong.

Similar kinds of analysis drawing on IS and EC research methods are offered in Simon's (2001) study of code-switching in French-as-a-foreign-language classrooms in Thailand. Teachers are seen as code-switching for a number of purposes, among which are those of negotiating different frames (e.g., formal, institutional learning frame vs. informal friendly frame), role-relationships, and identities (e.g., teacher vs. friend). Code-switching is seen as having a "momentary boundary-levelling effect" in the classroom (Simon 2001, p. 326). Whether similar effects might be achieved by code-switching in different contexts would, however, seem to depend on different sociolinguistic statuses and values associated with different codes in different societies.

In studies along this line, IS and EC analytical concepts and methods are drawn upon to analyze instances of classroom code-switching. The findings look

remarkably similar across different sociocultural contexts. Code-switching is seen to be an additional resource in the bilingual/multilingual teacher's communicative repertoire enabling her/him to signal and negotiate different frames and footings, role-relationships, cultural values, identities, and so on in the classroom (e.g., Merritt et al. 1992; Ndayipfukamiye 2001). These studies have the effect of uncovering the good sense or the local rationality (or functions) of code-switching in the classroom. To summarize by drawing on the functional view of language from Halliday (1994), code-switching can be seen as a communicative resource used by classroom participants (usually the teacher but sometimes also students) to achieve the following three kinds of purposes:

1. Ideational functions: Providing basic-L2-proficiency students with access to the L2-mediated curriculum by switching to the students' L1 to translate or annotate (e.g., key L2 terms), explain, elaborate, or exemplify L2 academic content (e.g., drawing on students' familiar life world experiences as examples to explain a science concept in the L2 textbook/curriculum). This is very important in mediating the meaning of academic texts that are written in an unfamiliar language – the L2 of the students.
2. Textual functions: Highlighting (signaling) topic shifts, marking out transitions between different activity types or different focuses (e.g., focusing on technical definitions of terms vs. exemplifications of the terms in students' everyday life).
3. Interpersonal functions: Signaling and negotiating shifts in frames and footings, role-relationships and identities, change in social distance/closeness (e.g., negotiating for in-group solidarity), and appealing to shared cultural values or institutional norms.

Apart from the above studies which draw on interpretive research paradigms, there is also a major trend of studies led by Monica Heller and Marilyn Martin-Jones (2001), which draws on both interpretive and critical research paradigms and they relate micro interactional functions of code-switching in the classroom to larger societal issues, such as the reproduction or sometimes contestation of linguistic ideologies in the larger society (e.g., which/whose language counts as standard and valued language, which/whose language counts as inferior or not-valued language). Heller and Martin-Jones provided some examples on how micro ethnographic studies of classroom code-switching are not actually "micro" in their implications if we see the classroom as a discursive site for reproduction or contestation of linguistic ideologies and hierarchies. The discursive construction/negotiation of what counts as front stage and back stage (Goffman 1974) and the legitimation of what goes on in the front stage (largely controlled and set up by the teacher) as legitimate, standard, and valued language, comparing to what gets marginalized, reproduced as inferior, non/substandard language in the back stage. Usually the societal dominant L2 occupies the first position and students' L1 occupies the latter position. For instance, in Ndayipfukamiye's (2001) study of Kirundi-French code-switching in Burundi classrooms, the bilingual teacher is seen to be using Kirundi (students' familiar language) to annotate, explain, and

exemplify French (L2) terms and academic content. While the linguistic brokering functions of code-switching is affirmed (the value of providing students with access to the educationally dominant language, French), the linguistic hierarchy as institutionalized in the French immersion education policy in Burundi is largely reproduced in these code-switching practices.

However, not all studies are about reproduction of linguistic ideologies and practices. For instance, Canagarajah (2001) shows how ESL teachers and students in Jaffna (the northern peninsula of Sri Lanka that has been the political center of the Tamils) negotiated hybrid identities through code-switching between Tamil and English, defying both the Tamil-only ideology in the public domains and institutions, and the English-only ideology from the ESL/TESOL pedagogical prescriptions from the West. Canagarajah argued that both teachers and students, by code-switching comfortably between these two languages, are also constructing their bilingual cosmopolitan identities, refusing to be pigeonholed by essentializing political ideologies (of Tamil nationalism) or English-only pedagogical ideologies. Lin (1999) also showed that by skillfully intertwining the use of L1 (Cantonese) for a story focus with the use of L2 (English) for a language focus, a bilingual teacher in a Hong Kong English language classroom successfully got her students interested in learning English and gaining confidence in reading English storybooks, and thus transforming the habitus of these working class students for whom English had been an alien language irrelevant to their daily life. Drawing on Heap's (1985) notion of discourse format, which was in turn built on Sinclair and Coulthard's (1975) seminal analysis of the Initiation-Response-Feedback (IRF) exchange structure, Lin further offered a fine-grained analysis of how L1-L2 code-switching was built into two kinds of IRF discourse formats to enable the teacher (Teacher D) to engage students in both enjoying the story and in learning English through this process:

Teacher D uses two different IRF formats in the following cycle in the reading lesson:

1. Story-Focus-IRF:
  - Teacher-Initiation [L1]
  - Student-Response [L1]
  - Teacher-Feedback [L1]
2. Language-Focus-IRF:
  - Teacher-Initiation [L1/L2]<sup>1</sup>
  - Student-Response [L1/L2]
  - Teacher-Feedback [L2], or use (2) again until Student-Response is in L2
3. Start (2) again to focus on another linguistic aspect of the L2 response elicited in (2), or return to (1) to focus on the story again

This kind of discourse practice allows the teacher to interlock a story focus with a language focus in the reading lesson. There can be enjoyment of the story, via the use

<sup>1</sup>“L1/L2” denotes “L1 or L2.”

of the story-focus IRF, intertwined with a language-learning focus, via the use of the language-focus IRF. It appears that by always starting in L1, Teacher D always starts from where the student is – from what the student can fully understand and is familiar with. The fine-grained sequential analysis of classroom code-switching drawing on both Sinclair and Coulthard's (1975) IRF analytical tradition and conversation analysis (CA) continued in later work as exemplified in Üstünel and Seedhouse's (2005) study on how learners displayed their alignment or misalignment with the teacher's pedagogical focus in an EFL classroom in a Turkish university. The fine-grained discourse analytic methods were also productively used in conjunction with a stimulated recall procedure in Scott and De La Fuente's (2008) study of the role of L1 when pairs of intermediate-level college learners of French and Spanish are engaged in consciousness raising, form-focused grammar tasks.

---

## Work in Progress

This section examines more recent research that takes slightly different research angles. These include approaches from diverse fields such as cognitive processing perspectives and experimental methodologies.

Macaro (2009) studied the effect of code-switching on students' vocabulary learning. In the study, a sample of 159 Chinese learners of English, aged 16, were randomly assigned to two different conditions. The context was a reading class in which the teacher orally interacted with the whole class around two challenging English texts. There were two sessions, each with a different text, and the conditions were rotated with each text. In the first condition, the teacher provided a first-language equivalent of words in the text that she knew her students were unfamiliar with as determined by a pretest of vocabulary knowledge. In the second condition, the same teacher provided learners with English definitions of the same unfamiliar words. Students in each condition were thus given different *types* of information about unknown words (code-switch vs. paraphrase). A third group was an intact class that acted as a control group, which was given *both* types of information (code-switch and paraphrase). A pretest of receptive vocabulary showed that the target vocabulary items were all unfamiliar to the students that there were no statistically significant differences in their vocabulary knowledge between the three classes, and additionally the three classes were chosen because they did not differ in general English proficiency according to their school proficiency tests. Students were given an immediate posttest and a delayed posttest after 2 weeks. Macaro concluded that there is "no harm" in giving L1 equivalents of words during the teaching activity around the reading texts in terms of long-term vocabulary acquisition and he further hypothesized that giving L1 vocabulary equivalents "lightens the cognitive load freeing up processing capacity to focus on the meaning of the text as a whole" (2009, p. 43).

Continuing with the experimental approach to find evidence on the impact of code-switching on vocabulary learning, Tian and Macaro's (2012) investigated the effect of teacher code-switching on EFL vocabulary acquisition during listening

comprehension activities in a lexical Focus-on-Form context. Eighty first-year students of English as an L2, in a Chinese university, were stratified by proficiency and randomly allocated to a code-switching condition or to an English-only condition, and their performance in vocabulary tests compared to a control group of 37 students that did not receive any lexical Focus-on-Form treatment. Results confirmed previous studies that lexical Focus-on-Form leads to better vocabulary learning than mere incidental exposure. More importantly the results also provided initial evidence that teacher code-switching to L1 may be superior to the teacher providing L2-only information on vocabulary learning.

---

## Problems and Difficulties

In this section I outline the major problems or difficulties that seem to be inhibiting advancement of our work in this area of studies. I hypothesize that these difficulties have arisen in part from the ideological environment that have implicitly pushed researchers towards a “normalizing mission” for their studies. The difficulties include a lack of design-interventionist, theory-driven, and interdisciplinary studies.

### Lack of Design-Interventionist Studies

Researching code-switching in the classroom, unlike researching other kinds of related classroom phenomena (e.g., classroom discourse, classroom interactions), has often been engaged in consciously or unconsciously with a legitimating motive or “normalizing mission” (Rampton et al. 2002, p. 375). Given the official pedagogical prescription of the use of only one language in the classroom in many contexts), many researchers have studied classroom code-switching practices to seek out their “good sense” or local rationality, or their positive impact on teacher-student relationships, students’ interest level, and various aspects of learning. These (implicit) aims have often shaped the research questions and research approaches used in classroom code-switching studies.

Because of these (implicit) legitimating concerns, researchers tend to be descriptive rather than interventionist; they describe existing practices rather than experiment with innovative ways of code-switching practices as ways both to provide access to (content in) L2 and to critique linguistic hierarchies and pedagogical dogmas (e.g., the monolingual principle; see a critique of these pedagogical dogmas by Levine 2011) in the larger society and institutions. Because of the lack of design interventionist research questions, the majority of studies in the classroom code-switching literature tend to offer little new insight into how existing classroom code-switching can be further improved to achieve more, such as more of the transformation of student identities (e.g., Canagarajah 2001; Lin 1999) and more understanding of how L1 can be used with a greater positive impact on specific aspects of learning (e.g., Macaro 2009; Tian and Macaro 2012). The findings of the bulk of the existing research literature thus seem to be variations on similar themes

without providing new research questions and research approaches to achieve new findings beyond what has already been known (and repeated frequently) in the literature on classroom code-switching.

### **Lack of “Disciplinary Plurilinguals”**

Coupled with the above difficulty is the tendency of fragmentation or compartmentalization of researchers from different research paradigms without much cross-fertilization or interillumination. For instance, there is a dearth of research studies that attempts to utilize transdisciplinary perspectives or a combination of research paradigms and approaches, and there is a lack of researchers who are “disciplinary bilinguals” (i.e., researchers who are well versed in multiple research paradigms and methods, both interpretive and experimental) (Rampton et al. 2002, p. 388; and I would add “disciplinary pluralilinguals”). However, to tackle the enormous task of charting out when, how, in what stage of the lesson, with whom, by whom, and in what kinds of tasks, code-switching can be used productively with what kinds of effect would require nothing short of concerted research efforts breaking disciplinary boundaries and drawing on a whole range of theoretical perspectives and research methods.

### **Scarcity of Theory-Driven Research Questions**

Research questions in the field tend to arise from practical classroom concerns (e.g., to uncover the good sense or rationality of the existing practices). While this is a normal source of research questions in education research, if the research literature cannot build up an expanded, diversified repertoire of theoretical frameworks that will motivate the formulation of increasingly sophisticated research questions, the studies would tend to be overly descriptive and repetitive (e.g., the classroom code-switching literature tends to be replete with studies describing the useful classroom functions of existing code-switching practices). Recent studies that draw on cognitive theories of vocabulary learning (e.g., Macaro 2009) would seem to be a welcoming development, although we also need to complement these approaches with approaches from the interpretive and critical paradigms as classroom code-switching involves not only cognitive processing but also identity/ideology reproduction (or transformation).

### **Lack of Variety in Research Designs**

There is a lack of longitudinal studies. Studies in the literature tend to be one-shot or cross-sectional. There is scarcity of studies on students’ code-switching, and also written code-switching (but see Canagarajah 2011). There is a lack of studies conducted by teachers (as teacher-researchers) or students (as student-researchers)

themselves on their own classroom code-switching practices (but see Song and Andrews 2009, for a study of four teachers' own perspectives on their code-switching instances in their classrooms through a stimulated recall procedure; their students' perspectives were also tapped using a similar procedure). There is also a lack of studies on the direct comparison of code-switching in the language and the content classrooms.

---

## Future Directions for Research

There have been very few to no published studies of the longitudinal, design-interventionist type. Also, most studies were conducted by a sociolinguist or a discourse analyst, usually an outsider coming into the classroom studying the interactional practices of classroom participants. These limitations in existing studies make it difficult for us to know what will happen if classroom participants (e.g., teachers, students) themselves become researchers of their own classroom practices, and what will happen if they embark on systematic study of their own practices, getting a deeper understanding of their own practices through their own research and then modify their own practices with systematic action plans and study the consequences, much like the kind of action-research carried out by the teacher-researcher. Below I outline what a future study might look like in order to achieve new insights into classroom code-switching:

1. Longitudinal research: Instead of one-shot classroom video/audiotaping studies, we need to have studies that follow the same classroom for a longer period of time (e.g., a whole course, a whole semester).
2. Design-interventionist studies: We need to integrate the sociolinguistic interpretive and conversation analytic with the action-research approaches so that the teacher becomes conscious of trying out specific bilingual classroom strategies with respect to achieving specific sets of goals. We also need to build into the research design ways of ascertaining the degree to which these goals are achieved. This is similar to the mode of teacher action-research. Close collaboration between teacher and researcher is also needed (e.g., the teacher is the researcher or there is close collaboration between the teacher and the researcher). Likewise, depending on the readiness of the students, students can also be solicited to become researchers in the study of their own bilingual classroom practices.
3. Viewing the whole lesson as a curriculum genre and investigating the role of L1 in different stages of the curriculum genre in different pedagogies: Much of the existing classroom code-switching research tends to look at code-switching instances as individual instances but not as an organic part of specific stages of a particular kind of curriculum genre as a whole. Rose and Martin (2012), for instance, differentiate between different kinds of curriculum genres in different kinds of pedagogies. In some stages of some curriculum genres, L1 might have a greater role than in other stages of the curriculum genres, and the kind of

curriculum genres that are readily acceptable often depends on the kind of pedagogy dominant in the field in different eras (see Mahboob's (2011) analysis of the different roles assigned to L1 in different kinds of L2 pedagogies in different eras).

4. Drawing up specific goals and designing specific bilingual classroom strategies to achieve those goals: This will require the teacher and researcher to understand the specific situated needs and goals of the educational context in which they find themselves. These educational goals need to be set up with reference to the needs and choices of participants in specific contexts, and not taken to mean any universal set of goals.
5. Drawing on research methods of genre analysis of discipline-specific academic discourses and literacies: For instance, we need to know what are the specific genre features and discourse structures of a biology course in order to design bilingual strategies to provide students with access to biology discourses through familiar everyday discourses. There will be frequent interweaving between academic discourses (mostly mediated in a less familiar language to the students such as the L2 or the "standard" dialect) and students' familiar discourses (e.g., everyday life examples and experiences mediated in students' familiar language such as their L1 or a home dialect). How the teacher can provide access to the formal, academic (often L2) discourses through the informal, everyday, familiar (often L1) discourses of the students' will become a key research question (e.g., Lin 2012).
6. Integrating the research of classroom code-switching with that of multimodality: for example, to view code-switching as continuous with mode-switching (e.g., Li 2011), and to investigate how classroom participants engage in classroom code-switching, mode-switching (or analysis of multimodality), and style-switching, all of which constituting an integrated repertoire of the communicative resources of classroom participants.
7. To systematically study the effectiveness of different bilingual classroom strategies, it will require a carefully planned integration of different research paradigms (including interventionist action-research, interpretive, critical) and research approaches (including those from sociolinguistics, academic genre analysis, pedagogical analysis, analysis of students' spoken and written samples of academic work, plus assessment of students' mastery of academic genre features and skills in performing academic tasks using the appropriate registers).
8. Taking a holistic and contextualized approach: We need to situate the classroom in its larger socioeconomic and political contexts and to reexamine the pedagogic goals of the classroom to see if they are really serving the interests of the students. Then we need to explore possible ways to achieve these goals including (but not limited to) bilingual classroom strategies. Both traditional (e.g., teacher whole-class instruction) and progressive pedagogies (e.g., student-inquiry groups) need to be used in conjunction with a consideration of which code-switching patterns can be intertwined with which pedagogical patterns and participant structures. All these require an approach that allows for try-and-see and then document and retry another pattern and see what happens and redesign future action plans that will



progressively better achieve the goals through both bilingual and other pedagogical practices.

The above suggestions might sound like an “unholy” eclectic approach to the linguistic or research methodological purist. However, to have breakthroughs in our current state of affairs in researching classroom codeswitching, we need to be both pragmatic and flexible in our research paradigms and approaches. We also need to concrete designs of bilingual classroom strategies and research studies that can systematically develop these designs and show their effectiveness (with respect to the situated goals of the classroom). When we can break away from the implicit grip of the “normalizing mission,” perhaps we can afford to be more critical of the research methods we have traditionally used to study classroom code-switching.

---

## Cross-References

- ▶ [Conversation Analytic Approaches to Language and Education](#)
- ▶ [Discourse Analysis in Educational Research](#)
- ▶ [From Researching Translanguaging to Translanguaging Research](#)
- ▶ [Research Perspectives on Bilingualism and Bilingual Education](#)

---

## Related Articles in the Encyclopedia of Language and Education

- Frances Christie: [Genres and Institutions: Functional Perspectives on Educational Discourse](#). In Volume: [Discourse and Education](#)
- Jasone Cenoz and Durk Gorter: [Translanguaging as a Pedagogical Tool in Multilingual Education](#). In Volume: [Language Awareness and Multilingualism](#)
- Ofelia García and Angel M.Y. Lin: [Translanguaging in Bilingual Education](#). In Volume: [Bilingual Education](#)

---

## References

- Adendorff, R. (1993). Code-switching amongst Zulu-speaking teachers and their pupils: Its functions and implications for teacher education. *Language and Education*, 7(3), 41–162.
- Alvarez-Caccamo, C. (2001). Codes. In A. Duranti (Ed.), *Key terms in language and culture* (pp. 23–26). Oxford: Blackwell.
- Bourdieu, P., & Passeron, J. C. (1977). *Reproduction in education, society and culture*. London: Sage.
- Canagarajah, S. (2001). Constructing hybrid postcolonial subjects: Codeswitching in Jaffna classrooms. In M. Heller & M. M. Jones (Eds.), *Voices of authority: Education and linguistic difference* (pp. 193–212). Westport: Ablex Publishing.
- Canagarajah, S. (2011). Translanguaging in the classroom: Emerging issues for research and pedagogy. In W. Li (Ed.), *Applied linguistics review* (pp. 1–28). New York: Walter de Gruyter.
- Creese, A., & Blackledge, A. (2010). Translanguaging in the bilingual classroom: A pedagogy for learning and teaching? *The Modern Language Journal*, 94(1), 103–115.

- Flanders, N. A. (1970). *Analyzing teaching behavior*. Reading: Addison-Wesley.
- Frohlich, M., Spada, N., & Allen, P. (1985). Differences in the communicative orientation of L2 classrooms. *TESOL Quarterly*, 19(1), 27–57.
- García, O. (2009). *Bilingual education in the 21st century: A global perspective*. Oxford: Wiley-Blackwell.
- Goffman, E. (1974). *Frame analysis*. New York: Harper and Row.
- Gumperz, J. J. (1984). Ethnography in urban communication. In J. C. P. Auer & A. Luzio (Eds.), *Interpretive sociolinguistics: Migrants, children, migrant children* (pp. 1–12). Tübingen: Narr.
- Guthrie, L. F. (1984). Contrasts in teachers' language use in a Chinese-English bilingual classroom. In J. Handscombe, R. A. Orem, and B. P. Taylor (Eds.), *On TESOL '83: The question of control* (pp. 39–52). Alexandria, Virginia: TESOL International Association.
- Halliday, M. A. K. (1994). *An introduction to functional grammar* (2nd ed.). London: Edward Arnold.
- Heap, J. L. (1985). Discourse in the production of classroom knowledge: Reading lessons. *Curriculum Inquiry*, 15(3), 345–379.
- Heller, M. (1999). *Linguistic minorities and modernity*. London: Longman.
- Heller, M., & Martin-Jones, M. (Eds.). (2001). *Voices of authority: Education and linguistic difference* (pp. 381–402). Westport: Ablex Publishing.
- Legarreta, D. (1977). Language choice in bilingual classrooms. *Journal of Social Issues*, 23, 9–16.
- Levine, G. S. (2011). *Code choice in the language classroom*. Bristol: Multilingual Matters.
- Lewis, G., Jones, B., & Baker, C. (2012). Translanguaging: Developing its conceptualisation and contextualization. *Educational Research and Evaluation*, 18(7), 655–670.
- Li, Wei. (2011). Multilinguality, multimodality, and multicompetence: Code- and modeswitching by minority ethnic children in complementary schools. *The Modern Language Journal*, 95, 370–384.
- Lin, A. M. Y. (1990). *Teaching in two tongues: Language alternation in foreign language classrooms*. (Research Report No. 3). Hong Kong: Department of English, City Polytechnic of Hong Kong. (ERIC Research Document # ED 399799).
- Lin, A. M. Y. (1996). Bilingualism or linguistic segregation? Symbolic domination, resistance and code-switching in Hong Kong schools. *Linguistics and Education*, 8(1), 49–84.
- Lin, A. (1999). Doing-English-lessons in the reproduction or transformation of social worlds? *TESOL Quarterly*, 33(3), 393–412.
- Lin, A. M. Y. (2012). Multilingual and multimodal resources in L2 English content classrooms. In C. Leung & B. Street (Eds.), *“English” – A changing medium for education* (pp. 79–103). Bristol: Multilingual Matters.
- Macaro, E. (2009). Teacher use of codeswitching in the second language classroom: Exploring “optimal” use. In M. Turnbull & J. Dailey-O’Cain (Eds.), *First language use in second and foreign language learning* (pp. 35–49). Bristol: Multilingual Matters.
- Mahboob, A. (2011). *Using local languages in English language classes*. <http://www.nnestblog.blogspot.com/>. Accessed 1 Sept 2011.
- Martin, P. W. (1996). Code-switching in the primary classroom: One response to the planned and unplanned language environment in Brunei. *Journal of Multilingual and Multicultural Development*, 17(2–4), 128–144.
- Martin, P. W. (2003). Bilingual encounters in the classroom. In J.-M. Dewaele, A. Housen, & Li Wei (Eds.), *Bilingualism: Beyond basic principles* (pp. 67–88). Clevedon: Multilingual Matters.
- Martin-Jones, M. (1995). Codeswitching in the classroom: Two decades of research. In L. Milroy & P. Muysken (Eds.), *One speaker, two languages: Cross-disciplinary perspectives on code-switching* (pp. 90–111). Cambridge: Cambridge University Press.
- Merritt, M., Cleghorn, A., Abagi, J. O., & Bunyi, G. (1992). Socializing multilingualism: Determinants of codeswitching in Kenyan primary classrooms. In C. M. Eastman (Ed.), *Codeswitching* (pp. 103–121). Clevedon: Multilingual Matters.
- Milk, R. (1981). An analysis of the functional allocation of Spanish and English in a bilingual classrooms. *California Association for Bilingual Education Research Journal*, 2(2), 11–26.

- Ndayipfukamiye, L. (2001). The Contradictions of teaching bilingually in postcolonial Burundi: From Nyakatsi to Maisons en Etages. In M. Heller & M. M. Jones (Eds.), *Voices of authority: Education and linguistic difference* (pp. 101–115). Westport: Ablex Publishing.
- Pennycook, A. (2010). *Language as a local practice*. New York: Routledge.
- Polio, C. G., & Duff, P. A. (1994). Teachers' language use in university foreign language classrooms: A qualitative analysis of English and target language alternation. *The Modern Language Journal*, 78(3), 313–326.
- Rampton, B., Roberts, C., Leung, C., & Harris, R. (2002). Methodology in the analysis of classroom discourse. *Applied Linguistic*, 23(3), 373–392.
- Rose, D., & Martin, J. (2012). *Learning to write, reading to learn: Genre, knowledge and pedagogy in the Sydney school*. Sheffield: Equinox.
- Sacks, H. (1965/1992). Lectures on conversation. In G. Jefferson (Ed.), *Lectures on conversation* (pp. 30–52). Oxford/Cambridge: Blackwell.
- Scott, V. M., & De La Fuente, M. J. (2008). What's the problem? L2 learners' use of the L1 during consciousness-raising, form-focused tasks. *Modern Language Journal*, 92(1), 100–113.
- Simon, D. L. (2001). Towards a new understanding of codeswitching in the foreign language classroom. In R. Jacobson (Ed.), *Codeswitching worldwide* (pp. 311–342). New York: Mouton de Gruyter.
- Sinclair, J., & Coulthard, R. M. (1975). *Towards an analysis of discourse*. London: Oxford University Press.
- Song, Y., & Andrews, S. (2009). *The L1 in L2 learning: Teachers' beliefs and practices*. Muenchen: Lincom Europa.
- Tian, L., & Macaro, E. (2012). Comparing the effect of teacher codeswitching with English-only explanations on the vocabulary acquisition of Chinese university students: A Lexical Focus-on-Form study. *Language Teaching Research*, 16(3), 367–391.
- Üstünel, E., & Seedhouse, P. (2005). Why that, in that language, right now? Code-switching and pedagogical focus. *International Journal of Applied Linguistics*, 15(3), 302–324.
- Wong-Fillmore, L. (1980). Learning a second language: Chinese children in the American classroom. In J. E. Alatis (Ed.), *Current issues in bilingual education: Georgetown university round table on languages and linguistics* (pp. 309–325). Washington, DC: Georgetown University Press.

---

# Researching the Language of Race and Racism in Education

Danny C. Martinez and Ramón A. Martínez

---

## Abstract

In this chapter, we consider how scholars have examined the relationship between language and race/racism in education. We highlight research that makes clear the language ideologies that circulate in educational settings, the resulting educational practices that privilege and institutionalize “mainstream” language practices while marginalizing and stigmatizing “non-mainstream” language practices, and the ways that race and racism are constructed and performed through language in educational contexts. We also consider the innovative methods introduced to the field as researchers questioned the deficit ways in which theories and methods stigmatized the languages of racialized groups.

---

## Keywords

Language • Race • Racism • Education • Sociocultural perspectives

---

D.C. Martinez (✉)

School of Education, University of California at Davis, California, CA, USA

e-mail: [dcmarr@ucdavis.edu](mailto:dcmarr@ucdavis.edu)

R.A. Martínez

Graduate School of Education, Center for Comparative Studies in Race and Ethnicity, Stanford University, Stanford, CA, USA

e-mail: [ramon.martinez@stanford.edu](mailto:ramon.martinez@stanford.edu)

## Contents

Introduction .....	504
Early Developments .....	504
Major Contributions .....	507
Work in Progress .....	511
Problems and Difficulties .....	512
Future Directions .....	513
Cross-References .....	514
Related Articles in the Encyclopedia of Language and Education .....	515
References .....	515

## Introduction

Language scholars have long conducted research to disrupt deficit perspectives that circulate about speakers of languages that differ from the “mainstream” (Hill 1998). However, we echo Hill, who almost two decades ago lamented how the “education” language scholars engage in has failed to alleviate misconceptions about language. Moral panics about bilingualism, Black English, and any language that “threatens” the hegemony of English are still heard today. Early sentiments of race as a biological trait continue to circulate, marking the cultural and linguistic practices of racialized groups as inferior to Whites. Omi and Winant (1994) have articulated that “race” is a social construct, yet a long history of Western nation states relying on race to stratify individuals continues to shade the experiences of racialized groups.

We consider how notions of race and racism are constructed and performed through language in various educational contexts. We highlight research that makes clear ideologies of language circulating in educational contexts, resulting in practices that deem “mainstream” languages a prerequisite for learning, simultaneously designating speakers of “nonmainstream” languages as resistant to schooling. While language researchers argue that *all* languages are structured and grammatical, references to languages as sloven, broken, and nonstandard have led to new ways of categorizing speakers in schools, indicative of language serving as a proxy for race (Gutierrez and Jaramillo 2006). We comment on methodological shifts and advances made by sociocultural language scholars to move the field away from deficit and ethnocentric perspectives toward more productive and humanizing research. While this chapter is US centric, we recognize that research on language, race, and racism in educational settings is an emerging area of interest in global contexts.

## Early Developments

Early language research treated speakers of non-European languages as lacking intellectual complexity or sophistication compared to speakers of European languages (see Menchaca 1997 for review). Nott and Gliddon (as cited in Menchaca

1997) concluded that, “. . .non-Whites spoke primitive languages reflecting a simplistic mentality,” based on survey research with over 50 non-White societies (p. 27). Menchaca suggests these findings were reached “because [Nott and Gliddon] found these languages difficult to understand in grammar and tone,” therefore erroneously proclaiming speakers “primitive or savage peoples” (p. 27). Perspectives such as these were commonly articulated about Mexicans and African Americans in the US context as well.

Boas (1889) was a prominent scholar who challenged deficit framings of communities, particularly findings characterizing Native American languages as “primitive.” Boas critiqued biological categorizations of individuals into “races,” which he believed supported “. . .political policies of colonialism, segregation of and discrimination. . .” against Blacks and immigrant groups (Lewis 2009, p. xii). Boas’ research documented languages spoken by Eskimo (Inuit) and Kwakiutl Indians of the Northwest United States by recording and transcribing narratives told by bilingual participants (Duranti 1997). He found that Native American languages were different, based on historical variability and not because of biological traits associated with speakers. He critiqued methods that “. . .created static rankings of culture traits according to the very theory [scholars] were trying to prove” (Lewis 2009, p. xi). Boas deemed previous research on Native American languages as empirically unsound suggesting that researchers themselves were limited in their ability to recognize sounds uncommon in their own languages. Sapir and Whorf continued the legacy of their mentor, Boas, debunking notions about “primitive” or “limited” languages (Sapir 1933) or of the existence of “simpler” and more “complex” languages based on surface level judgments of non-Western languages (Duranti 1997).

As language scholars attempted to understand the differences between communities, Bernstein (1964) presented his articulation of *elaborated* and *restricted* codes, arguing that middle-class children demonstrated elaborated codes that signaled higher forms of logic and lower class children engaged in restricted codes signaling less logical language. While widely critiqued, Bernstein brought attention to differences in language practices across social class groups. Labov (1969) challenged this perspective with his foundational piece, *The Logic of Non-Standard English*. He argued, “Bernstein’s views are filtered through a strong bias against all forms of working-class behavior, so that middle-class language is seen as superior in every respect—as ‘more abstract, and necessarily somewhat more flexible, detailed and subtle’” (p. 4). Labov demonstrated through his sustained research in Black communities in New York that there was a logic to the English spoken by Black communities, yet this “logic” was lost to researchers whose codes were different from those they researched.

Complementing this work was Gumperz and Hymes (1972) call for an “ethnography of communication.” Hymes (1964) urged linguists to research languages in the contexts of their use, and anthropologists to include language in their research on the cultural practices of groups. Additionally, he argued that researchers “must take as

context a community, investigating its communicative habits as a whole” (p. 3). He articulated,

When this is done, it will be found that much that has impinged upon linguistics as variation and deviation has an organization of its own. What seem variation and deviation from the standpoint of a single linguistic code emerge as structure and pattern from the standpoint of the communicative economy of the group in whose habits the code exists. (p. 3).

The ethnography of communication differed from previous language research that divorced language from its sociocultural context, particularly Chomskyan notions of linguistic competence. While the ethnography of communication did not explicitly interrogate race and racism, research from this tradition was foundational to treating and shifting attitudes toward the linguistic repertoires of racialized groups, specifically those of Black, Native American, Latina/o, and poor Whites. Methodologically, the ethnography of communication tradition urged researchers to move away from investigating language use in laboratories, and instead encouraged the investigation of language use within “natural” sociocultural contexts in ways that allowed researchers to observe and potentially engage in the everyday communicative activities of their participants. Long-term ethnographic methods were essential to documenting the uses and purposes of language use within a cultural community.

In 1965, the then US president, Lyndon Johnson’s administration received pressure from civil rights organizations over the dismal outcomes of students of color in US schools and convened a group of scholars to investigate potential reasons for this “deficiency” (Cazden et al. 1972 [1985]). During this meeting, Cazden (1972) recalls that all participants agreed “. . .that school problems could be better explained by differences in language use between home and school” (p. vii). This meeting resulted in the publication of *Functions of Language in the Classroom*, which Dell Hymes called a “hopeful book,” given that critiques offered by authors about the “present state of affairs” were followed up with suggestions on how practitioners and educators might make sense of the reported findings in order to address some of the most pressing educational issues that related to language. The authors moved the field toward methodologically sound research on the education of Black, Latina/o, and Native American children and youth in US schools inspired by the ethnography of communication and other interdisciplinary theories and methods from anthropology, sociology, linguistics, and psychology. Previous scholars, utilizing theories and methodologies steeped in deficit thinking placed blame explicitly on students’ culture of poverty and/or to their linguistic deprivation to place them at risk in schooling contexts (see Gutierrez et al. 2009 for review; Valencia 1997). Despite theoretical and methodological advances that will be explored in this chapter, it is still difficult to eradicate research that normalizes “mainstream” language practices, particularly as educational policies inform “standard” and “mainstream” ideologies of language that mediate curricular and instructional practices and discourses. This difficulty is perhaps a result of the power relations indexed through linguistic interactions, resulting in unmarked groups circulating ideologies that uphold their linguistic supremacy.

## Major Contributions

Heath's (1983) research received much praise for its attention to the "ways with words" of African American and White children across three communities in the Carolina Piedmont's with varied classed positions. Drawing on methods from the ethnography of communication, Heath's decade long research combined detailed linguistic and ethnographic analysis about the *differences* in language practices of children from Roadville (a working class White community), Trackton (a working class Black community), and Maintown (a middle-class Black and White community). She found that these children were socialized to and through language and literacy in ways that positioned White Maintown children as more aligned with language and literacy expectations of schools. On the other hand, Trackton and Roadville children were not academically successful, given their "divergent" language and literacy practices that did not align with the language and participation frameworks privileged in schools. While Heath did observe differences across "cultural" groups, the differences in the *ways with words* of children were attributed to their classed differences. It should be noted, however, that African American children in Maintown, while finding alignment in the ways of participating in schools, still did not benefit from all the privileges attained by White children whose ways with words mostly aligned with those of their teachers.

Duranti (1997) argues that ethnographic methods coupled with fine-grained linguistic analysis, such as those employed by Heath (and others reviewed below), allowed researchers to connect micro level communicative interactions with larger macro level phenomenon, such as language ideologies that might index constructions of race, class, and gender. In educational research, ethnographic methods help make clear the continuities and discontinuities existing for children, youth, and their families' from "nonmainstream" linguistic backgrounds, while simultaneously calling into question the validity of deficit approaches to learning.

The identification of these discontinuities were expanded by Philips (1983), who found that Native American children of the Warm Springs Reservation in Oregon were not participating in classroom interactions because of the different *styles of learning* to which they were accustomed. Specifically, Philips found that *participation structures* expected in the classroom by teachers did not align with the ways in which these children were expected to participate in their homes and communities. Similarly, Au (1980) found that participation frameworks used by teachers in Hawaii did not align with the "talk story" participation frameworks of Hawaiian children who were speakers of Hawaiian Pidgin. Both Au and Philips identified discontinuities between "home" and "school" practices. Au suggested that working with teachers to shift their participation frameworks to mirror those of their students helped increase involvement by children in the class, thus working toward denaturalizing mainstream participation frameworks. Reyes (2010) contends: "These studies reveal how ethnic majority groups establish and maintain power by having their speech norms legitimized in institutional settings, such as classrooms. Mainstream practices become accepted as 'normal,' 'proper,' and 'standard'" (p. 413). Au and Philips are often cited together because of their contribution to



the field's understanding of what participation structures are privileged in US schools. Their method of documenting how teachers organize learning, and the ways of participating within learning activities, provided a nuanced representation of how "non-mainstream" students' ways of participating were not considered or leveraged for learning. Rather, it was made evident that "mainstream" ways of participating were privileged.

Zentella's (1997) research examined the code-switching practices of Puerto Rican youth in New York City. These youth had expansive linguistic repertoires including their flexible ability to code-switch between English and Spanish, across varied communities. Educators, however, treated Puerto Rican youth as having incomplete languages. Zentella argued that schools engaged in subtractive educational practices, where Spanish and code-switching language practices of youth were subtracted. Rather, she proposed an additive approach to instruction where students *and* their teachers added languages to their linguistic repertoires. In Zentella's work, race became a much clearer marker as the languages of her youth participants indexed for the listener a racialized subject position. In this work, Zentella employed ethnographic methods supported by quantitative methods to capture both "how the community talks?" and "Why does this community talk this way?" (p. 6). Additionally, Zentella made clear the methodological tensions she faced being a member of the community she researched.

Alim (2004) is also credited with interrogating the racialized Black Language (BL) practices of youth at Sunnyside High, a school located in a Northern California community. While he found that Black Language was a linguistic feature of many Black youth, he also witnessed these youth *style shift* into and out of a range of languages. Specifically, he noted how youth shifted into a range of Englishes when speaking to various individuals associated with a local prestigious university. Specifically, when the university students considered themselves "hip-hop heads," no matter what their race, the youth were more flexible with their language practices when compared to the ways in which these youth spoke to university students who were avid listeners of hip hop. Alim's work highlighted how Black youth *have* the ability to shift but are often treated as having a singular "improper" way of using language. A closer examination of a well-intentioned teacher at these youths' high school highlights this point. The teacher in Alim's research attempts to convince him that the most difficult problem is having students drop the use of double negatives and the habitual *be* paramount to BL practices. In doing so, the teacher fails to follow one of the principal grammatical features of BL. Here it is important to add that Alim extended the sociolinguistic interview method traditionally used and introduced the semistructured conversation (SSC), where he asked his participants to engage in a conversation, in which he did not participate, about topics preselected based on his own ethnographic insights (p. 27). Alim argued that SSCs were methodological advancements that allowed for freer-flowing "natural" interactions to occur. Therefore Alim's work, like Zentella's (1997), benefited from both quantitative and ethnographic methods.

Rampton's (1995) notion of *language crossing*, or the "'code alternation' by people who are not accepted members of the group associated with the second language that they are using (code-switching into varieties that are not generally thought to belong to them)" (p. 485), is essential in research on race and language. Rampton's research, based in London in the UK, explored how speakers can "cross" into a "new ethnicity" or race via their ability to deploy the language associated with another ethnic or racial group. His work specifically detailed "the ways that youngsters of Asian and Anglo descent used Caribbean based Creole, the ways Anglos and Caribbean's used Punjabi, and the way stylized Indian English ('stylised Asian English'-SAE) was used by all three" (p. 489). While Rampton's work did not take place *in* schools, it revealed how cultural and linguistic contact between youth can have implications that affect the ways languages are deployed across racial and ethnic groups to maintain alignment. Importantly, Rampton was another scholar drawing on both sociolinguistic and linguistic anthropological methods. Rampton saw the benefits of quantitative sociolinguistics, yet he believed it was his ethnographic and interactional sociolinguistic methods that "were the most influential, and led to the examination of . . . closely interrelated dimensions of socio-cultural organization" (p. 489). Rampton also introduced the notion of retrospective participant commentaries where he asked participants themselves to comment on recorded interactions.

In the USA, language crossing has been explored in school settings where linguistic contact zones emerge for youth across racial and ethnic groups. In her research on "White kids," Bucholtz (1999, 2001) found that White youth in a San Francisco Bay Area school used "super-standard" English to index a "nerd" identity that distanced them from Black cultural practices that mediated notions of coolness among their White peers. Other White youth, particularly males, crossed into Black English to index an identity that aligned with Black peers. Bucholtz argued, "The operative racial ideology links power and violence primarily to blackness as opposed to whiteness. And the operative language ideology links AAVE both to blackness and to masculinity" (p. 445). Bucholtz admitted that the crossing that is described in her research does not promote "new ethnicities," as described by Rampton (1995). Instead, the crossing detailed in her analysis of Brand One presents his identity as an urban youth influenced by Black cultural and linguistic practices. Yet, instead of creating "cross-racial affiliations that may usher in a 'new ethnic' identity category (Hall [1989] 1996)" (cf., Bucholtz 1999, p. 456), Brand One's crossing suggests racist undertones that does nothing to create racial solidarity and instead promotes racial ideologies that are promoted by the dominant culture (Bucholtz 1999).

Rampton (1995) and Bucholtz (1999) both describe moments of language crossing whose endpoint produces different results in regards to ethnic solidarity and affiliation. In his ethnographic work in a California Bay Area high school, Paris (2011) extends the work on language crossing in his coining of the term *language sharing*, ". . . momentary and sustained uses of the language that are ratified – when use of the language traditionally 'belonging' to another group is ratified as

appropriate by its traditional speakers” (p. 14). Paris’ research examined Latina/o and Pacific Islander students who were speakers of Black Language in youth spaces that were influenced by “. . .demographic shifts coupled with the continued residential segregation of poor communities of color [which] have increased the numbers of Black and Brown students who share the same communities and classrooms” (p. 12). Paris states that methodologically, he engaged in “the qualitative social language work of discourse analysis, the ethnography of communication, and linguistic anthropology” yet he draws on his knowledge of quantitative sociolinguistics as “. . .a descriptive entry point to treat certain linguistic features of [African American Language] AAL.”

Sociocultural language and literacy scholars who draw on language ideological inquiry have also contributed to understanding languages as “raced” during everyday classroom experiences of children and youth. Razfar (2005), for example, draws on conversation analysis and language ideological theories to bring attention to the ways in which teachers of English language learners engage in “other repair,” that is, the correction of the speech of others, as the “normative assistance strategy employed by instructors to facilitate oral literacy skills” (p. 410). “Other repair” practices were deployed by teachers to “correct” youths’ pronunciation in ways that align with speaking and sounding White (p. 411). Godley and Escher (2012) turned to Black youth themselves to discover their own language ideologies. These youth, who attended an urban high school in a Midwestern US city, demonstrated a keen awareness of their code-switching from what they called Standard American English to African American English Vernacular. For these youth, their ability to “code-switch” was important because (1) they feared external judgment based on their use of BL particularly in “professional settings,” (2) they desired clear communication with their varied interlocutors, (3) they also wanted to demonstrate respect for others by using the language deemed appropriate respective of their interlocutor, and (4) there existed an implicit sense of individual and group identity that youth mediated through language.

Other scholars have continued to center their attention on the ideas and beliefs of children and youth of color to explore how their teachers and other educators treat their everyday utterances across their communicative interactions. For example, Souto-Manning (2010) used ethnographic and discourse analytic methods to explore the deficit perspectives children in a head start program indexed in their comments toward children who spoke languages different from their own. Souto-Manning engaged in discourse analytic methods to link these interactions to larger ideologies of language that shape the ways in which children allow access and exclude their peers via their language abilities. In his work with older students, Martinez (2013) explored the contradictory language ideologies of Latina/o middle school youth as they engaged in discussions about their Spanish/English code-switching. He found that students articulated both “dominant language ideologies that framed Spanglish in pejorative terms and counter-hegemonic language ideologies that valorized and normalized this bilingual language practice” (p. 276). He argued these contradictions are part of larger, structural systems of inequity that Latina/o youth are making sense of as they engage in their educational experiences.

## Work in Progress

Close examinations of the intersectional relationship between language, race, and racism are emerging in educational scholarship. Recent scholars clearly acknowledge the racial markedness of language and dominant institutions and groups who benefit from ideologies of language that sustain linguistic supremacy (Alim and Reyes 2011). One notable shift is the move by scholars to decenter the White racialized subject as the unmarked interlocutor (e.g., Baquedano-Lopez et al. 2005; Reyes 2010). Fewer researchers are interested in demonstrating how the language practices of racialized children and youth in schools are *not* like those of their White counterparts. Researchers are also less concerned about resolving discontinuities between the home and community language practices of racialized children and youth and schools (Orellana et al. 2012). Instead, researchers are considering the linguistic ingenuity of racialized children and youth by examining how they do “being” bilingual, multilingual, and/or multidialectal.

An important contribution in this direction is offered by Alim and Reyes’ (2011) who complicate language research in their argument that the field must move away from both “dialect oriented” and “group oriented” studies of language. The former focuses on a specific dialect and the latter centralizes a specific group to detail linguistic practices. Instead, they call for scholarship that “. . .depart[s] from both the dialect and group orientations by highlighting how processes of race and racialization are produced between groups and across multiple linguistic and social dimensions” (p. 380). This methodological shift makes clear that within a respective community, a researcher will encounter many “languages” and speakers with varied racial and ethnic affiliations. Given the increasing diversity of public schools in the USA, schools attended by racialized groups foster the emergence of linguistic contact zones. As Paris (2011) highlights, it may no longer be appropriate to research Black Language by only examining the linguistic repertoires of Black youth in the USA. Doing so would neglect the experiences of other racialized youth who partake in the “crossing” or “sharing” of languages. Martinez (2015) found that urban English language arts teachers in the USA neglected to leverage and treat the home and community languages of Black and Latina/o youth as a resource for learning. Instead teachers marked the racialized languages of these youth through corrective feedback practices, stigmatizing Black languages and other hybridized languages uttered by Black and Latina/o youth.

In another line of inquiry, Alim and Smitherman (2012) challenge indexical connections triggered when Whites characterize the utterances of Blacks as “articulate.” Using President Barack Obama’s discourse as an example, they argue that Black people, or people of color, more generally, who speak in ways that mirror dominant discourses are told they are articulate in ways that positions the speaker as an anomaly to the hearer. That is, you speak well for being Black. Alim and Smitherman argue instead that Obama *is* articulate because of his ability to style shift and engage various audiences via his dynamic and robust linguistic practices, the very practices that many Black youngsters become marked in their using.

Increasingly, linguistic anthropologists and other language scholars have shifted towards a focus on the role that language plays in the processes of *racialization* (Chun and Lo 2015; Malsbary 2014). Rather than examine how racialized groups of speakers use language in distinctive ways or even how individual speakers agentively draw on linguistic features to co-construct particular racialized identities, these scholars have begun to emphasize the ways that racial categories themselves are constructed and reified through language practices, including the role that language ideologies play in these semiotic processes (e.g., Flores and Rosa 2015). Methodologically, this turn towards racialization has prompted a call for increased attention to the ways that educators perceive, interpret, and respond to the language practices of students of color.

---

## Problems and Difficulties

As the language of race and racism in education has developed into an area of scholarly focus, some key tensions have emerged. First, there is a fundamental tension between perspectives that *reify* the everyday language practices of students of color (i.e., by calling them “varieties”) and those that characterize these practices as the *fluid, dynamic, and agentive* use of semiotic resources by speakers. This tension is reflective of broader disciplinary debates between variationist sociolinguistics and linguistic anthropology. From a historical perspective, variationist sociolinguistics was instrumental in progressive efforts to combat deficit discourses and promote multicultural approaches to pedagogy. Beginning in the late 1960s and early 1970s, progressive education scholars began to draw on the growing body of sociolinguistic research to frame stigmatized and marginalized language practices as “dialects” that were logical, rule-governed, and systematic (Conference on College Composition and Communication 1974). It is important to note that, as these scholars have increasingly begun to embrace linguistic anthropological perspectives, they have often moved towards these new perspectives *from* a variationist sociolinguistic perspective. In other words, their starting point for beginning to deconstruct sociolinguistic categories has involved an understanding of language variation – that language varies across time and space and that all language varieties are equal in purely linguistic terms. In contrast, many teachers and students in today’s schools have *not* been exposed to these basic sociolinguistic principles and related terminologies. They have not had time to be steeped in the knowledge that all ways of speaking are inherently equal – to let these basic sociolinguistic understandings sink in. A related question that emerges, then, has to do with the relative merits and usefulness of these two perspectives as part of critical language education. More to the point, if teachers and students have never been told that their ways of speaking are equal to all other ways of speaking, is it strategically important or necessary to reify their everyday language practices – to elevate these practices to the status of “language” or “dialect” or “register” – before proceeding to deconstruct these very categories? Should we begin, instead, with the linguistic anthropological notion that linguistic structure is the emergent

product of social interaction before introducing sociolinguistic perspectives on the relationship between linguistic and social structure? Or might we sidestep the variationist perspective altogether by moving directly towards a deconstruction of reified linguistic varieties? How might moving beyond a focus on dialect or group help us deconstruct reified linguistic categories? How might the reification of linguistic categories be a necessary step towards this deconstruction? These questions are important to consider in light of shifting conceptual paradigms among language scholars.

A second (and related) tension in this burgeoning field has to do with the notion of *adding to* or *expanding* students' linguistic repertoires. As mentioned above, the foundational literature in this area helped us understand the rich and varied ways that students of color use language across interlocutors and contexts. Taken together, this literature has given us a sense of the expansive *linguistic repertoires* (Gumperz 1964) that these students bring to the classroom. The notion of linguistic repertoire relies to a certain degree on the reification of language practices. Nonetheless, it has been a useful metaphor for helping to conceptualize the bundles of semiotic resources that students draw on in their everyday interactions. A key question that emerges is whether or not (and how) teachers should attempt to *expand* students' linguistic repertoires. For example, should teachers provide students with access to *standardized* language practices? Is it coercive to do so? Does providing students with such access contribute to the reification of standardized language practices? Does it contribute to the reproduction and institutionalization of dominant language ideologies? How might teachers give students access to standardized language practices without denigrating students' everyday language practices? How can teachers discern whether or not their students *already* incorporate standardized language practices (or particular features thereof) in their everyday talk? If we assume that students' everyday ways with words necessarily exclude standardized language practices, does this in turn rely on and reproduce essentialist ideas about *how* people from certain racialized groups talk, about how they *should* talk, and about what it means to be an *authentic* speaker of a particular language or dialect? How do students' everyday language practices overlap with the kinds of academic language and literacy privileged in school settings? Is it possible for teachers to both *affirm* and *expand* students' linguistic repertoires? These questions, and the tensions and contradictions that they evoke, will need to be answered as we move towards more culturally responsive language pedagogies. Additional classroom-based research, including ethnographic studies and collaborative design-based research with practitioners, will help us move in this direction.

---

## Future Directions

The field of language research in education must continue to rethink what counts as language in educational contexts with full understandings of the tensions that exist in schools around the teaching of "standard" or "academic" forms of language. We must be clear that asking children and youth of color to stop speaking the languages

of their homes and communities is just as harmful as practices that limited access to education merely decades ago. Future work in the area of race and racism in language research seeks to confront the “White gaze” that has historically framed the ways in which learning operates in schools and society. Paris and Alim (2014) argue that “. . .the goal of teaching and learning with youth of color was not ultimately to see how closely students could perform White middle-class norms but to explore, honor, extend, and problematize their heritage and community practices” (p. 86). Flores and Rosa (2015) also

. . .argue that the ideological construction and value of standardized language practices are anchored in what we term *raciolinguistic ideologies* that conflate certain racialized bodies with linguistic deficiency unrelated to any objective linguistic practices. That is, raciolinguistic ideologies produce racialized speaking subjects who are constructed as linguistically deviant even when engaging in linguistic practices positioned as normative or innovative when produced by privileged White subjects. (p. 150).

Both Paris and Alim, and Flores and Rosa point us to the future of research on the language of race and racism in education. Both papers argue for a shift away from the White gaze and instead ask us, in different ways, to center the experiences of children and youth of color in schools who have for too long existed in and have been subjected to acting and sounding like their White counterparts. Specifically, Flores and Rosa (2015) call for attention to move away from the speaker, particularly minoritized speakers, and instead center attention on the hearer. They argue,

Specifically, a raciolinguistic perspective seeks to understand how the White gaze is attached both to a speaking subject who engages in the idealized linguistic practices of whiteness and to a listening subject who hears and interprets the linguistic practices of language-minoritized populations as deviant based on their racial positioning in society as opposed to any objective characteristics of their language use. (p. 151).

Such a move requires another shift in our methods as we reposition our analysis away from comparing racialized groups in schools to their White counterparts. It also requires that researchers resist powerful ideologies of language that has always mediated educational policy and practice. As noted in this section, future work in this area must attend to race explicitly and address how racist discourse circulates in educational contexts, particularly in schools where children and youth of color are continually marked for their racialized language practices.

---

## Cross-References

- ▶ [Critical Ethnography](#)
- ▶ [Discourse Analysis in Educational Research](#)
- ▶ [Ethnography and Language Education](#)
- ▶ [Linguistic Ethnography](#)
- ▶ [Variationist Approaches to Language and Education](#)

## Related Articles in the Encyclopedia of Language and Education

Arlette Ingram Willis: [Critical Race Theory](#). In Volume: Literacy

---

## References

- Alim, H. S. (2004). *You know my steez: An ethnographic and sociolinguistic study of styleshifting in a Black American speech community*. Durham: Duke University Press for the American Dialect Society.
- Alim, H. S., & Reyes, A. (2011). Complicating race: Articulating race across multiple social dimensions. *Discourse and Society*, 22(4), 379–384.
- Alim, H. S., & Smitherman, G. (2012). *Articulate while Black: Barack Obama, language, and race in the U.S.* New York: Oxford University Press.
- Au, K. H. (1980). Participation structures in a reading lesson with Hawaiian children: Analysis of a culturally appropriate instructional event. *Anthropology and Education Quarterly*, 11(2), 91–115.
- Baquedano-López, P., Solís, J. L., & Kattan, S. (2005). Adaptation: The language of classroom learning. *Linguistics and Education*, 16(1), 1–26.
- Bernstein, B. (1964). Elaborated and restricted codes: Their social origins and some consequences. *American Anthropologist*, 66(6\_PART2), 55–69.
- Boas, F. (1889). On alternating sounds. *American Anthropologist*, 2(1), 47–54.
- Bucholtz, M. (1999). You da man: Narrating the racial other in the production of White masculinity. *Journal of Sociolinguistics*, 3(4), 443–460.
- Bucholtz, M. (2001). The whiteness of nerds: Superstandard English and racial markedness. *Journal of Linguistic Anthropology*, 11(1), 84–100.
- Cazden, C. B., John-Steiner, V., & Hymes, D. H. (1972). *Functions of language in the classroom*. New York: Teachers College Press.
- Chun, E. W., & Lo, A. (2015). Language and racialization. In N. Bonvillain (Ed.), *The Routledge handbook of linguistic anthropology* (pp. 220–233). New York: Routledge.
- Conference on College Composition and Communication. (1974). Students' right to their own language. *College Composition and Communication*, 25(3), 1–32.
- Duranti, A. (1997). *Linguistic anthropology*. New York: Cambridge University Press.
- Flores, N., & Rosa, J. (2015). Undoing appropriateness: Raciolinguistic ideologies and language diversity in education. *Harvard Educational Review*, 85(2), 149–171.
- Godley, A. J., & Escher, A. (2012). Bidialectal African American adolescents' beliefs about spoken language expectations in English classrooms. *Journal of Adolescent and Adult Literacy*, 55(8), 704–713.
- Gumperz, J. J. (1964). Linguistic and social interaction in two communities. *American Anthropologist*, 66(6), 137–153.
- Gumperz, J. J., & Hymes, D. (1972). *Directions in sociolinguistics: The ethnography of communication*. New York: Holt, Rinehart and Winston.
- Gutierrez, K. D., & Jaramillo, N. E. (2006). Looking for educational equity: The consequences of relying on Brown. *Yearbook of the National Society for the Study of Education*, 105(2), 173–189.
- Gutiérrez, K. D., Morales, P. Z., & Martínez, D. C. (2009). Re-mediating literacy: Culture, difference, and learning for students from nondominant communities. *Review of Research in Education*, 33, 213–245.
- Hall, S. [1989] (1996). New ethnicities. In David Morley and Kuan-Hsing Chen (eds.) *Stuart Hall: Critical Dialogues in Cultural Studies*. London: Routledge. 441–449.
- Heath, S. B. (1983). *Ways with words: Language, life, and work in communities and classrooms*. New York: Cambridge University Press.



- Hill, J. H. (1998). Language, race, and White public space. *American Anthropologist*, 100(3), 680–689.
- Hymes, D. (1964). Toward ethnographies of communication. *American Anthropologist*, 66(6), 1–34.
- Labov, W. (1969). The logic of non-standard English. *Georgetown monographs on language and linguistics*, 22(1), 1–31.
- Lewis, H. S. (2009). Introduction. In F. Boas (Ed.), *Anthropology and modern life* (pp. ix–xvi). New Brunswick: Transaction Publishers.
- Malsbary, C. (2014). “Will this hell never end?”: Substantiating and resisting race-language policies in a multilingual high school. *Anthropology and Education Quarterly*, 45(4), 373–390.
- Martínez, R. A. (2013). Reading the world in *Spanglish*: Hybrid language practices and ideological contestation in a sixth-grade English language arts classroom. *Linguistics and Education*, 24(3), 276–288.
- Martínez, D. C. (2015). Black and Latina/o youth communicative repertoires in urban English language arts classrooms. In E. Morrell & L. Scherff (Eds.), *New directions in teaching English: Reimagining teaching, teacher education, and research* (pp. 59–79). New York: Roman & Littlefield.
- Menchaca, M. (1997). Early racist discourses: The roots of deficit thinking. In R. R. Valencia (Ed.), *The evolution of deficit thinking: Educational thought and practice*. Washington, DC: The Falmer Press.
- Omi, M., & Winant, H. (1994). *Racial formation in the United States: From the 1960s to the 1990s* (2nd ed.). New York: Routledge.
- Orellana, M. F., Martínez, D. C., Lee, C. H., & Montaña, E. (2012). *Language as a tool in diverse forms of learning*. *Linguistics and Education*, 23(4), 373–387.
- Paris, D. (2011). *Language across difference: Ethnicity, communication, and youth identities in changing urban schools*. New York: Cambridge University Press.
- Paris, D., & Alim, H. S. (2014). What are we seeking to sustain through culturally sustaining pedagogy? A loving critique forward. *Harvard Educational Review*, 84(1), 85–100.
- Philips, S. U. (1983). *The invisible culture: Communication in classroom and community on the Warm Springs Indian Reservation*. Prospect Heights: Waveland Press.
- Rampton, B. (1995). Language crossing and the problematisation of ethnicity and socialisation. *Pragmatics*, 5(4), 485–513.
- Razfar, A. (2005). Language ideologies in practice: Repair and classroom discourse. *Linguistics and Education*, 16(4), 404–424.
- Reyes, A. (2010). Language and ethnicity. In N. H. Hornberger & S. L. McKay (Eds.), *Sociolinguistics and education*. Buffalo: Multilingual Matters.
- Sapir, E. (1933). Language. In *Encyclopedia of the social sciences* (Vol. 9, pp. 155–169). New York: Macmillan.
- Souto-Manning. (2010). *Teaching English learners: Building on cultural and linguistic strengths*. *English Education*, 42(3), 248–262.
- Valencia, R. R. (1997). *The evolution of deficit thinking: Educational thought and practice*. Washington, DC: Falmer Press.
- Zentella, A. C. (1997). *Growing up bilingual: Puerto Rican children in New York*. Malden: Blackwell Publishers.

---

# Research Approaches to the Study of Literacy, Learning, and Technology

Ilana Snyder and Ekaterina Tour

---

## Abstract

Since desktop computers were introduced into educational settings in the late 1970s, researchers have been trying to find ways to explain the meaning-making processes involved when digital technologies are used that might inform curriculum and pedagogy. Much important work has been done to devise effective ways to investigate the complex connections across literacy, learning, and technology. This chapter provides an international perspective on how researchers in universities and schools, working either independently or collaboratively with teachers, have studied the changes to social and cultural practices associated with the use of technology for educational purposes. As evident here, the history of the approaches to research parallels the trajectory of the wider area of educational studies. The first investigations were most often quantitative; there was a gradual shift to qualitative methods and then multiple perspectives were adopted that drew on methods from both traditions. However, it would be a mistake to represent the history as a process of evolution. Each of the earlier waves is still operating in the present as a set of practices that researchers follow or argue against. An array of choices now characterizes the field with no single approach privileged. Faced by the still largely uncharted landscape of the Internet in which young people are often the navigators, messier, less certain, more reflexive, multi-voiced research is seen as the best way to respond. However, it is likely that making meaning in digital settings will continue to be complicated by the fluid, metamorphosing, unpredictable nature of online worlds.

---

I. Snyder (✉)

Faculty of Education, Monash University, Clayton, VIC, Australia  
e-mail: [ilana.snyder@monash.edu](mailto:ilana.snyder@monash.edu)

E. Tour (✉)

Monash University, Melbourne, VIC, Australia  
e-mail: [katrina.tour@monash.edu](mailto:katrina.tour@monash.edu)

© Springer International Publishing AG 2017

K.A. King et al. (eds.), *Research Methods in Language and Education*, Encyclopedia of Language and Education, DOI 10.1007/978-3-319-02249-9\_40

517

---

**Keywords**

Literacy • Learning • Technology • Research practices

**Contents**

Introduction .....	518
Early Developments .....	518
Major Contributions .....	520
Work in Progress .....	523
Problems and Difficulties .....	525
Future Directions .....	526
Cross-References .....	527
Related Articles in the Encyclopedia of Language and Education .....	528
References .....	528

---

**Introduction**

Since desktop computers were introduced into educational settings in the late 1970s in the economically developed world, researchers have been trying to find ways to explain the meaning-making processes involved when information and communication technologies (ICT) are used that might inform curriculum and pedagogy. Much important work has been done to devise effective ways to investigate the complex connections between literacy, learning, and technology. This chapter provides an international perspective on how researchers in universities and schools, working either independently or collaboratively with teachers, have studied the changes to social and cultural practices associated with the use of technology for educational purposes.

The history of the approaches to research parallels the trajectory of the wider area of educational studies. The first investigations were most often quantitative; there was a gradual shift to qualitative methods and then multiple perspectives were adopted that drew on methods from both traditions. However, it would be a mistake to represent the history as a process of evolution. Each of the earlier waves is still operating in the present as a set of practices that researchers follow or argue against. An array of choices now characterizes the field with no single approach privileged.

---

**Early Developments**

Investigating written composition, pioneering researchers asked if computers used as word processors improved writing (Daiute 1986). Although survey and case study methods were employed to examine students' attitudes and responses to computers, these early studies were most often experimental or quasi-experimental in design. They assessed whether the quality of texts produced with computers was better than those produced with pens. Not surprisingly, the findings were equivocal: some

studies produced evidence of enhanced quality but just as many found no improvement. The research question asked about the “impact” of computers “on” writing. It attributed too much power to the technology and not enough to the social and cultural contexts in which the computers were used. There was a short answer to the question: Do students write better with computers? It depends – on the writers’ preferred writing and revising strategies, keyboarding skills, prior computer experience, teaching interventions, the teachers’ goals and strategies, the social organization, and culture of the learning context.

Largely from the perspective of cognitive psychology, early research also examined the effects of the use of computers on composing processes, particularly prewriting and revising (e.g., Daiute 1986). Other studies concentrated on writing pedagogy, often a process approach that teachers adopted when introducing the technology, examining the computer as a felicitous tool that might facilitate and enhance a process approach (e.g., Sommers 1985).

By the mid-1980s, sociocultural understandings of literacy became more widely accepted and provoked different kinds of questions and orientations. With the gradual shift to a view of reality as socially constructed, the approach became more ethnographic; researchers examined “computer-mediated” contexts from multiple perspectives (Hawisher and Selfe 1989). The field was in transition: some researchers were operating in the current-traditional paradigm, concerned with correctness and error; some were operating in the writing-process paradigm; and some were beginning to adopt the social view.

At the end of the 1980s, feminist criticism, cultural criticism, and critical pedagogy were all invoked to inform the research. There was a hiatus in the war between quantitative and qualitative approaches and the researcher was increasingly understood as implicated in research processes. The emphasis on context made gender issues central to discussion of literacy, learning, and technology, and there was a growing recognition that computers in classrooms appear “unlikely to negate the powerful influence of . . . social class and its effects on . . . success or failure in school” (Herrmann 1987, p. 86).

In the 1990s, researchers began to ask different kinds of questions. Qualitative methods, including participant observation and interview, seemed the best way to investigate the nexus between literacy, learning, and technology. Cochran-Smith et al. (1991) worked with teachers and students in five elementary classrooms over two years to explore how computers made learning to read and write different. In a case study that involved active participant observation, Miller and Olson (1994) found that the existence of innovative practice associated with the introduction of computers in the classroom had less to do with the advent of technology than with the teacher’s pre-existing conception of practice.

Some researchers continued to investigate the influence of word processing on writing quality and revision strategies but took into account variables that had confounded the earlier studies. These included the students’ word processing experience, their writing ability, and the effects of teacher interventions or bespoke software (e.g., Joram et al. 1992; Owston et al. 1992). The findings were correspondingly more persuasive.

Researchers have also examined the use of electronic forums to support student-centered learning by comparing face-to-face with electronically mediated exchanges. They concluded that the use of networked communication shaped and was shaped by the curriculum and that the interaction between the two modes may lead to better academic performance (e.g., Palmquist 1993). By contrast, other researchers argued that computer-mediated peer review had many of the drawbacks of distance learning. A comprehensive review of the first decade of research addressed the difficulties of interpreting studies that reflect contrasting conceptual frameworks and which differ in design, methods of data collection, variables examined, and modes of analysis (Bangert-Drowns 1993).

Hypertext, electronic text that contains links to other text, became a research focus in the 1990s (Snyder 1996). Using qualitative approaches, such as observation, semi-structured interviews, and student journals, researchers described hypertext's potential to improve teaching and learning. By transferring to students the responsibility for accessing, sequencing, and deriving meaning from information, hypertext provided an environment in which discovery learning might flourish. In the teaching of writing, the use of hypertext promoted associative thinking, collaborative learning, synthesis in writing from sources, distribution of traditional authority in texts and classrooms, and the facilitation of deconstructive reading and writing.

---

## Major Contributions

Increasingly, the Internet, including the Web after 1992, has become a site for research. Informed by the understanding of literacy as a set of social practices, key investigations have focused on issues of identity (Turkle 1995), class and access (Burbules and Callister 2000), the maleness of the Web (Takayoshi et al. 1999), multimodality (Kress and van Leeuwen 2001), and new literacy practices (Lankshear and Knobel 2011). The research findings emphasize the need to teach students how to critically assess the reliability or value of the information they find on the Internet by understanding not only its textual but also its nontextual features such as images, links, and interactivity.

In addition to social approaches, critical and poststructuralist perspectives have also garnered researchers' interest, suggesting a further range of methods and modes of analysis. Rather than blaming technology for the failure of schools or the end of books and reading, more measured approaches (e.g., Selfe 1999) have suggested the importance of critical engagement with digital technologies in the context of education. Researchers have criticized short-sighted policy efforts that have spent large amounts of money on technology without first asking questions about use, support, and learning (Cuban 2001). Others have pointed to the nonneutrality of computing technologies and how over time they tend to become naturalized (Burbules and Callister 2000). Yet others have represented digital technologies, not as the harbingers of strengthened democracy, increased freedom and more support for educators, but as instruments of social control and dependence, both in wider society and for teachers and students in schools (Selwyn and Facer 2013).

The *Digital Rhetorics* study (Lankshear et al. 2000) exemplifies qualitative research informed by the understanding of literacy as social practice. This relatively large-scale study of eleven research sites across Australia argues that in the age of the Internet, education must enable young people to become proficient in the operational, cultural, and critical dimensions of literacy. The analysis suggested five principles for practice when ICT are used: teachers first, complementarity, workability, equity, and focus on trajectories.

In an ethnographic study of Internet use in four language classrooms in Hawaii, Warschauer (1999) illustrates the complex relationship between literacy, learning, technology, and culture. Drawing on interviews, classroom observations, and examples of students' work, Warschauer argues that "electronic literacies" are destined to become a vital component of literacy education; print-based reading and writing are only one element of the repertoire of literacy capabilities students require to participate fully in civic society. Whether they are called electronic literacies, digital literacies, multiliteracies, or new literacies, they comprise significant ways of making meaning in the contemporary world.

Popular culture has also received attention. Research has highlighted the benefits of using "nonschool" literacies in schools for consolidating and extending students' understandings of how texts are read. Often perceived as antithetical to mainstream print-based literature, using case study and discourse analysis, researchers have demonstrated how video and computer games require complex literacies that extend students' knowledge and teach a degree of multimodal visual and linguistic sophistication often ignored in curriculum design (Gee 2003). After examining the learning theory underpinning "good" video games, Gee concludes that it resembles the best kind of school science instruction.

In a similar way, Warschauer's (2006) large-scale, multi-site study examined laptop programs in ten US schools using observation, interview, survey, and document review. The research reported that literacy practices in the laptop programs were more autonomous, student-centered, audience-based and collaborative and, thus, more engaging, authentic, and meaningful for students. However, the findings were not consistent across all the participating schools and classes. Warschauer's study provides insight into the complex relationships between school and out-of-school practices. It highlights the need to teach students to engage with digital technologies effectively and critically, while identifying the constraints that might limit achieving this goal.

*The Handbook of Research on New Literacies* (Coiro et al. 2008) comprises a comprehensive collection of studies which are informed by multiple theoretical perspectives, employing different research designs. The volume demonstrates the range of approaches that have been used to study digital literacies and practices, but it does not represent the last word on such research. Systematic inquiry in the field of literacy, learning, and technology continues to flourish.

Building on studies that had begun to reconceptualize literacy in digital times, researchers have attempted to document the distinctive characteristics of digital literacies and practices. Using interview as the main research technique, Sheridan and Rowsell (2010) examined the practices, stories, and products of 30 digital media

producers to understand the logic of marketplace production. They characterize digital literacy practices as multimodal, hybridized, recombinative, constantly arranging, and rearranging themselves from the available designs, modes, genres, and resources of the digital medium. In these ways, they are both creative and innovative.

In their analysis of social networking and remixing, Lankshear and Knobel (2011) describe digital literacy practices as participatory, collaborative, shared, and distributed. In a study of Flickr, the photo-sharing website, Barton and Lee (2013) used an online survey, observation, interview, and user-generated photography to identify the characteristics of participants' digital literacy practices. They describe these practices as dynamic, fluid, creative, and stance-taking.

Ethnographically oriented studies, as distinct from full-blown ethnographies, have enabled researchers to conceptualize how opportunities for literacy learning are shaped by the sociocultural, political, and economic contexts in which they are located. Social class is one of the most significant influences identified by researchers operating in this tradition. Using semi-structured interviews with children and their parents, Marsh (2011) argued that children's literacy practices in a virtual world were shaped by the material contexts of their lives. The more privileged children in the study had greater opportunities to extend their repertoires of digital literacy practices. Drawing on analysis of a survey of the mobile phone practices of people living in a remote Indigenous community in northern Australia and a video of a literacy event in which a young boy and his mother used a mobile phone, Auld, Snyder, and Henderson (2012) identified significant sociocultural influences at play. The study found that the use of mobile phones, designed for individual and private use, was shaped by community values that privilege the sharing of resources.

Ethnographically oriented studies have also produced illuminating examples of how technology travels locally, nationally, and internationally, how it is adopted by people within particular communities, but also how it is exposed to the inescapable influences of globalization (Barton and Lee 2013). Such empirical work has contributed a translocal and transnational perspective on digital literacies and practices.

Of the many research overviews (e.g., Mills 2010), Andrews' work *The Impact of ICT on Literacy Education* (2004) remains thought-provoking in the context of this chapter's focus. The analysis concludes with a mixed set of findings. For some learners, it seems that ICT bring no improvement in educational outcomes and, in some instances, their use actually makes things worse. As a caution against technological optimism, Andrews proposes that randomized trials should precede further investments in ICT for literacy education. His recommendation is significant as it reflects the growing demand by governments for "hard" evidence to inform the policy directions they have sometimes already chosen. However, Andrews' confidence that rigorously designed randomized trials evaluating the impact of ICT will attach scientific evidence to direct future policy settings is optimistic. As discussed, experimental designs do not capture the interactive, iterative, and dialogical character of literacy learning and teaching. By contrast, research approaches, informed by broader understandings of literacy as social practice, provide more nuanced accounts of the use of digital technologies in education.

Drawing on large-scale surveys of young people's engagement with legacy and new media, Livingstone (2002, 2012) has investigated the relationships between the media and childhood, the family and the home. As a useful counterpoint to such survey studies, in-depth case studies of young people both at school and at home provide deeper understanding of how technology is used in the real world of inequitable distribution. Snyder, Angus, and Sutherland-Smith (2002) investigated the ways in which four families used computers to engage with formal and informal literacy learning in home and school settings. The findings drew together issues of access, equity, and cultural capital in the context of school success and failure. However, there is still a relative lack of studies that combine large-scale surveys with detailed case studies in the field of literacy, learning, and technology (e.g., Warschauer 2006).

Exploring the possibilities for creative changes to pedagogical and institutional practices when digital technologies are used, researchers have argued that understanding the history of digital literacies and practices is essential. They have asked how literacies, technologies, and social circumstances have co-evolved and what changes in literacy practices mean for young people. They conclude that literacy is inextricable from community, from the ways that communities and society change, and from the material means by which knowledge is negotiated, synthesized, and used. Valuing the lessons to be learned from history, Lankshear and Knobel (2011) describe how the field has moved from the study of "reading" to the New Literacy Studies, reminding readers that just 30 years ago the term literacy hardly featured in formal educational discourse.

Like the earlier research, recent work has found that digital technologies, particularly social media, offer learning opportunities for young people. In her large-scale survey and interview study, Ito (2010) concluded that interest-driven networked communities encourage peer-based learning. This finding overlaps with Lankshear and Knobel's (2011) notion of "social learning," illustrated in their two case studies of new literacies in formal education contexts. Gillen (2009) and Marsh (2011) used virtual ethnography to examine young children's and teenagers' literacy practices in virtual worlds. Both concluded that participation in virtual worlds promotes the learning of sophisticated literacy capabilities. Barton and Lee (2013) also observed voluntary, informal, and purposeful learning amongst multilingual adults who used Facebook, Flickr, and instant messaging. Their research highlighted that interacting online is embedded in people's everyday social practices and can provide important opportunities for learning.

---

## Work in Progress

Although the trend has been there since the first decade of research, researchers continue to acknowledge the need to pay attention to the social, cultural, and political changes associated with the use of digital technologies in educational settings. Finding ways to use the technologies' affordances in productive ways but at the same time helping students to become capable, critical users remains a major



preoccupation. Often implicit in research proposals and reports is the understanding that the relationship with technology is never one-way and instrumental: it is always two-way and relational.

Finding the language to talk about digital literacies and practices and discerning how meanings are made with them continue to be a research focus. Researchers are examining young people's literacy practices in the context of online culture, highlighting the fusion of visual, textual, and structural elements. They are exploring how different semiotic modes contribute to meaning-making in digital spaces and that what goes on behind the screen is just as important for users as what is visible on it. Concerned with what it is not immediately apparent to users, Manovich (2013) argues that the world is no longer defined by heavy industrial machines that change infrequently but by software that is always in flux. As software has replaced the diverse array of physical, mechanical, and electronic technologies used to create, distribute, and access digital artifacts, Manovich's work has profound implications for literacy education: understanding the design of the software that shapes contemporary cultural practices has become essential.

Contemporary studies employ a range of different methods to investigate research questions in naturalistic settings: participant observation, interview, focus groups, document review, and analysis of participants' digital products. However, with the exponential growth of online spaces and the increasingly important role trans-media experiences play in people's everyday lives, changes in research methods continue to emerge. Virtual ethnographies or studies that use elements of virtual ethnographies are becoming more prevalent. The digital texts generated and used by people in different online contexts for different purposes are now a research focus. These digital texts take multiple forms: blogs, online discussions, social media, photos, profiles, websites, wikis, music, videos, memes, emails, chat logs, and many more. Researchers such as Sheridan and Rowsell (2010) and Barton and Lee (2013) have explored such texts. Their work demonstrates how understanding of online literacy practices is enhanced when researchers become both producers and consumers of the texts they are examining.

Participatory action research is also emerging as a popular approach. Concerned about the slowness of change (if at all) in educational settings when digital technologies are used, some researchers have attempted to take an active role in the inquiry (e.g., Apperley and Beavis 2011). The researchers work together with teachers in schools to systematically study their classrooms, students, and teaching methods to enhance understanding, develop a plan for action, and improve the quality and impact of their work. As in the broader field of educational studies, it is increasingly argued that action research is the only ethical way to do research because it treats participants as collaborators rather than subjects. As it aims to demystify the research process, it enables teachers to do their own research. Action research places responsibility on the teacher participants and involves reflexivity as the inquiry unfolds. However, there are inherent challenges when teacher participants are considered less as subjects and more as research partners. These include the power relationship between participants and researchers, organizational politics, anonymity and confidentiality, negotiating time-consuming demands of professional and research practices, and the validity of data.

## Problems and Difficulties

The literacy landscape is changing, as it has always done, but more rapidly and more fundamentally. As new sites for research emerge, sites that are virtual and boundless, researchers are faced with the challenge of how to investigate them effectively. Researchers require flexible, sensitive frameworks for understanding and portraying the complex phenomena of technology-mediated literacy settings. At the same time, researchers find themselves pressured to work within the constraints of a positivist paradigm as funding bodies increasingly provide support mainly for “evidence-based” research (Lather 2004). The kinds of questions asked and the kinds of studies carried out are directly affected by this trend. More than ever, researchers need to “think outside the box” and to resist automatically adopting approaches to research dictated by conservative funding regimes.

Another difficulty with research in this area is that technological determinism – the assumption that qualities inherent in the technology itself are uniquely responsible for changes in social and cultural practices – continues to permeate academic discourse. Digital technologies are credited with transforming education systems and democratizing schools. Electronic forums are represented as open spaces in which issues related to gender, race, and socioeconomic status are minimized. Such claims, however, need to be interrogated as they overlook the human agency integral to all technological innovation. No technology can guarantee any particular behavior simply by its nature, as its use and effect are closely tied to the social context in which it appears. Technology succeeds or fails not only by its intrinsic design but also as a result of how it is used by people and institutions that take it up. Researchers need to assume a critical perspective to explore the implications of the cultural and ideological characteristics of technology use in educational settings.

Some challenges have emerged with the move by researchers to the investigation of online spaces. Informed by the logic of traditional methodologies, researchers in digital environments have tended to simply transfer ethnographically oriented methods to the Internet. While many of these research approaches appear to be effective, a number of ethical dilemmas specific to online spaces have emerged. First, both researchers and participants might have created online identities that are different from their real-life ones. These practices throw into question the authenticity of data and the validity of findings. Second, it is not clear if it is ethical for researchers to use extracts published publically online without the authors’ consent. Third, it is near impossible to gain the informed consent of participants in online environments as the communities in virtual worlds and social media are often heavily populated and constantly changing. Ethical concerns associated with privacy, identity authentication, informed consent, authenticity of data, and validity of findings still remain unresolved for researchers. They represent very complex matters for researchers to think about and require some adjustment of research methods in the context of online research.

Unfortunately, the dynamics of doing research in digital spaces, especially the difficulties that researchers inevitably face, are often sanitized in the literature. There is too often minimal reflection on how the research was conducted and complex

issues dealt with. This absence provides little guidance for other researchers. Reflection on research processes is integral to developing and sustaining researchers' knowledge and capabilities. Analyzing complex situations, reporting how issues were negotiated and resolved, and explaining how decisions were made extend the body of knowledge related to planning, designing, and conducting research in this field. Researchers who reflect on their studies in their publications and presentations encourage more informed and critical research practices (e.g., Tour 2012).

Although some researchers still rue the cultural cost of the rise of digital technologies, a further difficulty for the field is the privileging of "newness." However, the so-called "new" literacy practices associated with the use of digital technologies do not simply represent a break with the past – old and new practices interact in far more complex ways, producing hybrid rather than wholly new practices. Indeed, the current tendency is not displacement but rather convergence – a coming together of previously distinct technologies, cultural forms, and practices, both at the point of production and reception. Just how a range of different forms of communication – writing, visual and moving images, music, sound and speech – are converging represents a serious challenge for researchers.

---

## Future Directions

The research agenda is rich with possibilities. Researchers should build on previous investigations, adding to the growing knowledge base about the connections between literacy, learning, technology, curriculum, and culture. In the first instance, a longitudinal approach to the study of young people immersed in online culture, in all the dimensions of their lives, would produce deeper understandings of digital literacies and practices. Attention also needs to be directed towards the intersection between languages and the different modalities of digital technologies. There are many educational settings in which multiple languages are used both inside and outside classrooms. Researchers need to investigate the place of multilingualism and multiculturalism in digitally mediated educational contexts.

In the context of constantly changing technologies, literacies, and practices, future research needs to draw on multiple perspectives: the visual arts and craft; music, film, and the performing arts; advertising and communication; linguistics and language studies; social semiotics; and graphic design and computer science. These disciplinary fields are likely to generate new understandings of the intimate connections between literacy, learning, and technology.

The need for further research investigating the complexity of digital literacies and practices in online spaces is manifest. Trans-media digital literacy practices have become more and more common as people engage in social, political, and professional activities in many different online environments. These literacies and practices are complex because they spin through multiple remixed modes, in various genres, in the context of different communities and digital environments. While virtual ethnographies often examine a particular online environment or community, there is a need for an integrated methodological approach that examines how literacy activities

developed on the Internet materialize in everyday life. Such research requires detailed, systematic analysis of online communications, discussions, and artifacts.

Further research aimed at investigating the complex relationships between the verbal and the visual in communication and representation would also provide opportunities to examine at close hand digital literacy practices in real contexts: to observe different online users, to discuss technology-mediated communication practices, and to apply to those practices understandings that draw on the work of theorists such as Gee (2003), Kress and Van Leeuwen (2001), Lankshear and Knobel (2011), and Sheridan and Rowsell (2010).

More research investigating the complex relationships between literacy, technology, and disadvantage is required. Research needs to keep up with technological and market developments in relation to access – to track shifting and diversifying contexts of use, including the institutional and social influences on young people’s Internet use, and to critically examine causes and consequences of exclusion. Systematic, detailed, ethnographically oriented studies of individuals, communities, and institutions continue to represent a valuable approach for researchers in this field.

As the use of digital technologies in the literacy curriculum is a contextual change that encourages alterations in the political, social, and educational structures of systems, it is important to look closely at how it is carried out. There needs to be more research into how language and literacy teachers integrate technology into curricula. Questions include: How does pedagogy change? Do teachers’ expectations alter? What are the implications for teachers’ professional development and for the training of pre-service literacy teachers? More research on patterns of resistance to the use of digital technologies is required. Why do teachers who work in environments that have technology facilities remain wary of its use in their classrooms, despite the fact that the world is increasingly dominated by the digital? There also needs to be care in ascribing to the technology powers it does not possess. If digital technologies are used in innovative ways, caution about inferring a cause and effect relationship between adopting them and effective teacher practice is essential.

Faced by the still largely uncharted landscape of the Internet in which young people are often the navigators, messier, less certain, more reflexive, multi-voiced research is the way to respond. However, it is likely that making meaning in digital settings will continue to be complicated by the fluid, metamorphosing, unpredictable nature of online worlds.

---

## Cross-References

- ▶ [Arts-Based Approaches to Inquiry in Language Education](#)
- ▶ [Researching Computer-Mediated Communication](#)
- ▶ [Researching Multimodality in Language and Education](#)
- ▶ [Visual Methods in Researching Language Practices and Language Learning: Looking at, Seeing, and Designing Language](#)

## Related Articles in the Encyclopedia of Language and Education

James Gee: [The Unity of Language, Literacy, Learning, and Digital Media](#).

In Volume: Language and Technology

Kevin M. Leander and Cynthis Lewis: [Literacy and Internet Technologies](#).

In Volume: Literacies and Language Education

---

## References

- Andrews, R. (Ed.). (2004). *The impact of ICT on literacy education*. London: Routledge Falmer.
- Apperley, T., & Beavis, C. (2011). Literacy into action: Digital games as action and text in the English and literacy classroom. *Pedagogies: An International Journal*, 6(2), 130–143.
- Auld, G., Snyder, I., & Henderson, M. (2012). Using mobile phones as placed resources for literacy learning in a remote Indigenous community in Australia. *Language and Education*, 26(4), 279–296.
- Bangert-Drowns, R. L. (1993). The word processor as an instructional tool: A meta-analysis of word processing in writing instruction. *Review of Educational Research*, 63(1), 69–93.
- Barton, D., & Lee, C. (2013). *Language online: Investigating digital texts and practices*. London: Routledge.
- Burbules, N. C., & Callister, T. A., Jr. (2000). *Watch IT: The risks and promises of information technologies for education*. Boulder: Westview Press.
- Cochran-Smith, M., Paris, C. L., & Kahn, J. L. (1991). *Learning to write differently: Beginning writers and word processing*. Norwood: Ablex Publishing Corporation.
- Coiro, J., Knobel, M., Lankshear, C., & Leu, D. (Eds.). (2008). *Handbook of research on new literacies*. New York: Lawrence Erlbaum Associates.
- Cuban, L. (2001). *Oversold and underused: Computers in the classroom*. Cambridge, MA: Harvard University Press.
- Daiute, C. (1986). Physical and cognitive factors in revising: Insights from studies with computers. *Research in the Teaching of English*, 20(2), 141–159.
- Gee, J. P. (2003). *What video games have to teach us about learning and literacy*. New York: Palgrave Macmillan.
- Gillen, J. (2009). Literacy practices in Schemes Park: A virtual literacy ethnography. *Journal of Research in Reading*, 32(1), 57–74.
- Hawisher, G. E., & Selfe, C. L. (Eds.). (1989). *Critical perspectives on computers and composition instruction*. New York: Teachers College Press.
- Herrmann, A. (1987). Ethnographic study of a high school writing class using computers: Marginal, technically proficient and productive learners. In L. Gerrard (Ed.), *Writing at century's end: Essays on computer-assisted instruction* (pp. 79–91). New York: Random.
- Ito, M. (2010). *Hanging out, messing around, and geeking out: Kids living and learning with new media*. Cambridge, MA: MIT Press.
- Joram, E., Woodruff, E., Bryson, M., & Lindsay, P. H. (1992). The effects of revising with a word processor on written composition. *Research in the Teaching of English*, 26(2), 167–193.
- Kress, G., & Van Leeuwen, T. (2001). *Multimodal discourse: The modes and media of contemporary communication*. London: Arnold Publishers.
- Lankshear, C., & Knobel, M. (2011). *New literacies: Everyday practices and classroom learning* (3rd ed.). Maidenhead: Open University Press.
- Lankshear, C., Snyder, I., & Green, B. (2000). *Teachers and technoliteracy: Managing literacy, technology and learning in schools*. Sydney: Allen & Unwin.
- Lather, P. (2004). This is your father's paradigm: Government intrusion and the case of qualitative research in education. *Qualitative Inquiry*, 10(1), 15–34.

- Livingstone, S. (2002). *Young people and new media: Childhood and the changing media environment*. London: Sage.
- Livingstone, S. (2012). Critical reflections on the benefits of ICT in education. *Oxford Review of Education*, 38(1), 9–24.
- Manovich, L. (2013). *Software takes command*. New York: Bloomsbury Academic.
- Marsh, J. (2011). Young children's literacy practices in a virtual world: Establishing an online interaction order. *Reading Research Quarterly*, 46(2), 101–118.
- Miller, L., & Olson, J. (1994). Putting the computer in its place: A study of teaching with technology. *Journal of Curriculum Studies*, 26(2), 121–141.
- Mills, K. A. (2010). A review of the “digital turn” in the New Literacy Studies. *Review of Educational Research*, 80(2), 246–271.
- Owston, R. D., Murphy, S., & Wideman, H. H. (1992). The effects of word processing on students' writing quality and revision strategies. *Research in the Teaching of English*, 26(3), 249–276.
- Palmquist, M. E. (1993). Network-supported interaction in two writing classrooms. *Computers and Composition: An International Journal for Teachers of Writing*, 10(4), 25–58.
- Selfe, C. L. (1999). *Technology and literacy in the twenty-first century: The importance of paying attention*. Carbondale: Southern Illinois University Press.
- Selwyn, N., & Facer, K. (Eds.). (2013). *The politics of education and technology: Conflicts, controversies, and connections*. London: Palgrave Macmillan.
- Sheridan, M. P., & Rowsell, J. (2010). *Design literacies: Learning and innovation in the digital age*. New York: Routledge.
- Snyder, I. (1996). *Hypertext: The electronic labyrinth*. Melbourne: Melbourne University Press.
- Snyder, I., Angus, L., & Sutherland-Smith, W. (2002). Building equitable literate futures: Home and school computer-mediated literacy practices and disadvantage. *Cambridge Journal of Education*, 32(3), 367–383.
- Sommers, E. A. (1985). *The effects of word processing and writing instruction on the writing processes and products of college writers*. ERIC Reproduction Service No. 269 762.
- Takayoshi, P., Huot, E., & Huot, M. (1999). No boys allowed: The world wide web as a clubhouse for girls. *Computers and Composition*, 16(1), 89–106.
- Tour, E. (2012). Cross-cultural journey into literacy research. *English Teaching: Practice and Critique*. Special Issue, 11(2), 70–80.
- Turkle, S. (1995). *Life on the screen: Identity in the age of the Internet*. New York: Simon and Schuster.
- Warschauer, M. (1999). *Electronic literacies: Language, culture, and power in online education*. Mahwah: Lawrence Erlbaum.
- Warschauer, M. (2006). *Laptops and literacy: Learning in the wireless classroom*. New York: Teachers College Press.

---

# Researching Computer-Mediated Communication

Wan Fara WanMansor and Mohamad Hassan Zakaria

---

## Abstract

This chapter describes computer-mediated communication (CMC) research within the contexts of current and emerging CMC sites (referred to as technologies), the role of CMC researchers, and the scope of language and education. As evident here, currently available CMC media allow researchers to explore research in varied settings and to address a broad scope of issues in the field. The development of CMC research has led to various methodological innovations which contribute to the complex, dynamic, and eclectic nature of research in language and education. While much educational research has been plagued by the oft-cited problems of the lack or absence of “good data,” data collected from CMC sites is normally abundant and, hence, richer. The rapid emergence of new technologies and changing ways of interactions on CMC sites calls for research paradigm shifts among traditional researchers. Research in language and education are not only multidisciplinary but also require multiple perspectives. The discipline, thus, demands specific problem formulation as well as the identification of conceptual and methodological gaps. Many CMC researchers have complemented or even challenged the “traditional” research in language and education, opening up new possible uncharted territories. CMC researchers, thus, need to understand the technologies, employ appropriate research design, and conduct research activities. The sections in this chapter highlight how CMC has (1) served as a rich research site for language and education, (2) offered methodological innovation as a result of its rapid research development, and (3) continued to present solutions and challenges to educational researchers.

---

W.F. WanMansor (✉) • M.H. Zakaria (✉)  
Foreign Language Department, Faculty of Arts, Taif University, Taif, Saudi Arabia  
e-mail: [farawm@gmail.com](mailto:farawm@gmail.com); [hassanutm@gmail.com](mailto:hassanutm@gmail.com)

---

**Keywords**

Multimodal CMC • Virtual ethnography • Social network sites • Mobile learning • Game-based learning • Multiple perspectives research

**Contents**

Introduction .....	532
Early Developments .....	533
Major Contributions .....	534
Current Work .....	537
Problems and Difficulties .....	538
Future Directions .....	540
Cross-References .....	541
Related Articles in the Encyclopedia of Language and Education .....	541
References .....	541

---

**Introduction**

Computer-mediated communication (CMC) (sometimes referred to as internet-mediated communication or simply technology-mediated communication) refers to human-to-human communication through the Internet, intranet, and extranet. It also includes text-based interaction between or among communication technology devices (e.g., text-messaging, text chat, email, blogs, wiki environment, twitter). Recent research in CMC has focused on the social aspects of CMC through the many mushrooming social network sites (SNS), mobile learning platforms, and webpages or web-based documents. Researching CMC in language and education, in particular, is concerned with the social networking, interaction, relationships and how they affect the learning and teaching of second or foreign languages, learning about other cultures around the world, forging friendships, and building communities that would motivate the users/learners to learn better. Due to the opportunities to collect data in various settings and the availability of rich data, ethnographic and qualitative methodologies, for instance, are gaining in popularity where researchers have become more innovative with collecting and analyzing data. Thus, many new technologies or platforms have been examined as well as new research methodologies.

Rapid developments in communication technologies and the need for inquiry into its influence on educational practices and values have offered rich insights into theoretical frameworks, research designs, and methodologies and have challenged researchers to be more innovative and adaptive. The wide-ranging scope of CMC research in language and education includes investigations of the effectiveness of the CMC tools on learners and learning, social interactive nature among individuals through CMC, the effects of the social networking, acquisition of specific skills, culture and intercultural competence, academic literacy, vocabulary development, collaboration, and pragmatic competence.



## Early Developments

Early developments in researching CMC in education began with the use of purely quantitative design which evolved into qualitative method with various mixed methodologies and research tools. The focus of the CMC research also were varied in which not just students' responses were analyzed but also teachers' opinions, evaluation on the teaching methods and computer programs, students' participation and interactions with each other as well as with the teachers, and on the process of learning.

One of the early developments in researching CMC was ENFI, first used in network-based classroom for teaching English composition (Bruce et al. 1993). ENFI was initially used among hearing impaired students learning English as a second language. These students learned to write compositions by interacting through ENFI, a local area network (LAN), with other students in the class. They were instructed to interact through ENFI to discuss their composition topics before they began to compose.

To evaluate the ENFI, students' responses to questionnaires were collected and analyzed quantitatively (Batson and Peyton 1986). Later, comparative studies, between ENFI and non-ENFI students and teachers, were also conducted qualitatively, such as interview and samples of writing, while questionnaires were analyzed quantitatively. Findings confirmed that the CMC interaction among the students played a positive role in the composing process and on their motivation to write. The use of ENFI marked the beginning of research in network-based classrooms (e.g., CMC in composition classes). The CMC environment of ENFI continues to be reevaluated while new and innovative research tools were built into the computer and the network.

The increasing use of CMC for E-Learning and distance education also encouraged research into, for example, the effectiveness of Internet communication on learners and learning (Berge and Collins 1995) and examining the experiences of students and course facilitators in courses delivered via CMC (Rohfeld and Hiemstra 1995). The qualitative methodology utilized the researchers' own perspectives and familiarity when examining their students' learning in their distance education program. It revealed the nature of participation in the learning and teaching and the adequacy of training and support on the electronic system. Through online mentoring, peer-review of writing or peer learning, simulations, personal networking, and course management, researchers were able to gather rich data for critical analysis and subsequently make further improvements on E-Learning and distance education as well as preparing the teachers and the learners.

With the growth of online and distance education programs, there is a need to evaluate the system design (the basis for developing CMC tools) in order to examine the requirements for the systems and its usage. An evaluation of the system design in E-Learning or distance education is crucial since a good system ensures effective communication via the different CMC tools being used in the study. Several works

on the evaluation of the online system design (Harasim 1990; Kerr and Hiltz 1982) have managed to capture the intricacies of CMC research and offered useful insights into the conceptualization of variables and research design. Kerr and Hiltz (1982), for example, in investigating the virtual classroom at the New Jersey Institute of Technology, provided comprehensive perspectives on researching CMC. In their attempt to investigate educational technology and educational effectiveness, they examined a variety of courses, students, and implementation environments through pre- and postcourse questionnaires, behavioral data, qualitative observations, and interviews. Many of these studies describe the process and outcomes of online education as well as measure the students' performance and effectiveness.

Kerr and Hiltz (1982) were pioneers in innovative methodological tools, described how the computer medium could capture and save interactions, such as computer conferencing among the participants for later evaluation and analysis. Since then, this technology continues to evolve becoming more user-friendly, error-free, and inexpensive and thus "permits greater research flexibility and potential productivity than do traditional methods" (p. 170). This encourages more CMC researchers to further examine the CMC environment.

Comparative approaches are also popular CMC research. Early on, many studies attempted to compare face-to-face (FTF) conversations to computer-assisted classroom discussion or CACD (Chun 1994; Kern 1995; Warschauer 1996). These studies compared CMC interactions with FTF, often examining the effects of such interactions on the development of participants' interactive competence, motivation, and participation. Among the methodologies used are field experiments (Benbunan-Fich and Hiltz 1999) and longitudinal and quasi-experimental (Kerr and Hiltz 1982). These comparative studies offer useful perspectives on the process and outcomes of traditional FTF courses versus online learning.

Thus, the dynamic development in CMC research reflects the diversity and complexity of research in language and education. CMC researchers have employed varied methodologies, explored diverse research settings, and analyzed many aspects of language and education. Herring (1996) saw the potential of CMC research, stressing that "the goal is to bring together a variety of approaches to CMC so that their insights might inform one another and direct future research" (p. 2). Her empirical observations addressed wide-ranging perspectives of CMC, which are linguistic, social, and cross cultural. The linguistics perspective questions the comparison of CMC with speaking and writing and describes its structural characteristics, while the social perspective discusses the groups, interests, and issues that emerged online. And finally the cross-cultural perspective examines the benefits and risks of communication across cultures through CMC.

---

## Major Contributions

Research in CMC has introduced many indispensable tools and methods for various disciplines in language and education due to its effectiveness, efficiency, and flexibility of its data collection methods and analysis. Experienced CMC researchers

would admit that online data has the potential to serve as valid and reliable data due to the greater control the researchers have on online research sites as well as the convenience of addressing specific research contexts or changing the necessary variables. In addition, CMC research normally yields rich data, the quantity that is needed in educational research, especially for qualitative studies. The contributions of CMC research can be discussed with regard to the (1) emphasis on qualitative and ethnographic methodology as well as multimodal CMC, (2) diverse CMC platforms explored, and (3) useful scope of language and education.

CMC researchers have utilized qualitative and ethnographic methodology using various research tools. A number of researchers examine EFL students' interaction in online discussion forum to provide them opportunities to develop intercultural communicative competence (Hanna and de Nooy 2009; Mollering and Levy 2012; Zourou and Loiseau 2013). Hanna and de Nooy (2009), for example, utilized qualitative research methods that include ethnography and discourse analysis of online texts.

Garcia et al. (2009), in their review of several CMC and Internet ethnographic research, stressed on the role of ethnographers in CMC environment, noting that "ethnographers must learn how to translate observational, interviewing, ethical and rapport-building skills to a largely text-based and visual virtual research environment" (p. 78). The change from FTF environment to online research sites requires researchers to adapt to the norms of CMC and the online community. For example, online interview, normally punctuated by emoticons and abbreviations, contains CMC-rich cultural nuances that would pose challenges to traditional interview analysts.

In terms of addressing the depth of analysis for CMC research, attempts were made by researchers to employ virtual ethnography as well as multiple data collection techniques or using multimodal CMC, synchronous and asynchronous. Hawkes (2009), for example, utilized action-research ethnography to investigate language learners' use of blogs, video, and email and collected data through classroom observation and students and staff interviews. Clark and Gruba (2010) went further in CMC research by exploring auto-ethnography by taking the role of language learners themselves and reflecting on their experience learning the target language online in *Livemocha*.

More recently, Sadler and Dooly (2013) utilized an ethnographic case study in their research on the virtual world *Second Life*, wherein recurrent patterns were found in the analysis of the language use within the virtual world context. This is due to the built-in capability of the Internet to interlink pages that contain history of interaction and previous writing behavior, which could also be used to support online collaboration and learning. Current technology is, thus, capable of providing CMC environment that allows creative and engaged participation during data collection, application of multimodal CMC Dooly and Hauck (2012), for instance, using synchronous (Instant Messaging and Chatting) and asynchronous (email, forum) as well as in-depth analysis of online data.

Another major contribution of research in CMC is the researchers' explorations of diverse CMC platforms, websites, or communities. Social network sites (SNS) such

as *Facebook*, *Livemocha*, *Busuu*, *Babbel*, and many others have been of interests of current CMC researchers. *Livemocha*, for instance, is a web-based language learning community (e.g., English, Spanish, Korean, Arabic, Mandarin Chinese, Japanese, and many other languages) that has online instructional content (drill and practice) wherein the community members (the native speakers of the language) could offer feedback to any members learning the particular language as well as have online chatting with the language learners. A number of studies have focused on *Livemocha*, for example, Harrison (2013) analyzed the “user profile” feature and the role it plays in the interactions of learners and “peer experts” and the effects on the learners’ language learning.

Blogs and wikis are also other popular platforms being investigated through the interactive media (Dooly and O’Dowd 2012; Kabilan et al. 2011) as well as virtual worlds (Panichi and Deutschmann 2012; Sadler and Dooly 2013). Within the various CMC sites, the social media tools for interaction were also evaluated, the social networking and interaction patterns that promote learning, as well as intercultural understanding and competence.

Another advancement of CMC research is its ability to capture various useful topics in language and education, for example, second and foreign language learning in Southeast Asia (Kabilan et al. 2012), mobile learning (Litchfield et al. 2007; Looi et al. 2010; Thomas et al. 2013), intercultural learning (Hanna and de Nooy 2009; Mollering and Levy 2012; Thomas et al. 2013), and teacher training (Hurtado and Llamas 2014; Kabilan et al. 2011; Whyte 2014). These wide-ranging topics are capable of addressing the multidisciplinary knowledge that language and education propagates.

Research in acquisition and development of skills and literacy within CMC (Cheng 2010; Kakh 2014) are important contributions since these research cover the scope of language and education. In developing students’ academic literacy, Cheng (2010) used qualitative analysis on the multiple sources of data she gathered: questionnaires, online discussion posts, students’ written assignments, and discourse-based and general interviews. Similarly, Kakh (2014) attempted to develop four nonnative students’ skills of writing through active revising of their literature review by scrutinizing the Google Docs environment. Through qualitative design and tools (Kakh 2014; WanMansor 2012) utilized virtual participant observation, focus-group interviews, learners’ journal entries, interactions, learners’ drafts, and the content subject e-moderator’s reflections as her sources of data through wiki (Google Docs). These are examples of studies that examine the influence of CMC on the students’ development of the skills within the social context of the online community.

With the rapid expansion and powerful capability of the computer network, new state-of-the-art data collection tools and analysis have also emerged as mentioned earlier in this section. Furthermore, the interactive nature of the CMC environment has certainly encouraged a multitude of CMC researchers to (1) explore the environment further, (2) generate (and combine) new research methods and tools, and (3) redefine their roles as researchers.

## Current Work

This section highlights current research projects that have managed to address gaps in current work and have the potential to generate further research. First, the studies captured the critically needed topics in language and education such as second or foreign language and culture learning, developing academic literacy and skills, and exploring on classroom literacy practices. Second, the research employed effective methodologies that may not be possible in FTF settings suggesting the opportunity for future extension or replication. A few recent and significant CMC research projects will be discussed here within two major areas in language and education: (1) the telecollaboration project for intercultural competence and foreign language learning (e.g., Ware and Kessler 2014; Park 2014) and (2) social network and online discussion to promote knowledge and skills among teachers or teacher trainees within teacher education program (e.g., Hurtado and Llamas 2014; Whyte 2014). In addition to the two areas, current CMC research have effectively exploited a variety of approaches: rich case study (e.g., Park 2014; Ware and Kessler 2014), qualitative approach with multiple data collection tools, and analysis (e.g., Kakh 2014; Park 2014).

Ware and Kessler (2014), for example, in their intercultural telecollaborative project in the second language classroom among public middle school adolescents between a US classroom and a class in Spain engaged multiple research tools, including interviews with teachers and students who participated in open-ended intercultural discourse questionnaire (IDQ). They use qualitative analysis software NVivo to analyze all the data such as students' transcripts through Google Blogger. They manage to provide rich case study description in their effort to investigate how technology might be used to support the adolescents' language use in the telecollaboration project. The objective of the study was to "offer the students opportunities to engage in international online communication in the context of school-based learning ... in shaping ... the students' use of and interaction with new technologies" (p. 21). Similarly, Park's (2014) research on intercultural telecollaborative learning made use of "multiple qualitative analytic methods ... including constant comparison, discourse analysis and case studies analysis" (p.vi). Data sources include the transcripts of naturally occurring online interaction, interviews with students and teacher on the Korean side of the telecollaboration, and students' course assignments such as reflective journals and papers.

Research among teachers and teacher trainees are also worthy of discussion here, particularly research that promotes teaching, technological, social, and language competences (Hurtado and Llamas 2014; Whyte 2014). In Whyte's (2014) research on social media use among preservice language teachers to develop their technopedagogical competences, she analyzed qualitatively and quantitatively her three types of data: students' group project work, reflective feedback (individual reaction papers and final group presentation), and a postcourse questionnaire. What is unique about Whyte's research is the use of multiple CMC sites including Scoop.it, Facebook, Tweeter, and Wiki (Google Sites) and the tasks assigned to the students.

In another research, Hurtado and Llamas (2014) experimented with Facebook as a resource to promote the teaching and learning process of a group of preservice teachers. They examined the influence of social networking on knowledge building to create closer links among the students and between the students and the teachers. By using a hands-on approach (utilized within the multi-method approach) and by utilizing CMC technologies to the fullest in order to optimize data collection and analysis, these projects illustrate an invaluable research design that should be useful for future CMC research.

Qualitative approaches and the use of multiple data collection tools and analysis allow the researchers to explore further with their data which is necessary in the acquisition of second or foreign language writing skills among nonnative students (Aydin and Yildiz 2014; Kakh 2014). While Aydin and Yildiz (2014) investigated the use of wiki in a foreign language learning classroom, three different wiki-based collaborative writing tasks, focus-group interviews, and questionnaires were their sources of data. More recently, Zheng et al. (2015) further investigated on wiki for collaborative learning in higher education.

Further exploration showed how research methodologies in CMC research can be innovatively modified, harnessed, and utilized to achieve the research goals. Besides attempting to capture the complexity of this CMC research, a multi-method approach is necessary for the purpose of triangulating whereby researchers need to cross-validate analysis from various data collected.

Although the categorization of qualitative, quantitative, and mixed approaches describes current CMC research, it may not capture the “hybridity” of approaches utilized in many studies. Loncar et al. (2014), in their analysis of 43 journal articles on asynchronous online discussion, discuss the presence of four dominant research paradigms: argumentative, comparative, relational, and analytical. Such categorization allows researchers to focus on the actual research problem and scope of investigation in order to benefit from the eclectic and hybrid nature of CMC research.

---

## Problems and Difficulties

The growing popularity and the abundance of CMC research should be viewed as a positive development but with caution. Traditional FTF researchers would argue that even with the presence of innovative research design such as those described above, we have yet to understand certain nuances of cultural or social phenomena that may affect research on language and education. For instance: how do CMC tools function compared to those of their FTF counterparts? In what ways do CMC tools complement them and richly contribute to research and knowledge in general?

As in traditional FTF methodological issues in education, CMC methodologies will continue to be debated as CMC research continues to flourish. Major concerns in traditional FTF research – validity, generalizability, and authenticity, which have influenced CMC research – have been duly addressed. Authenticating participants interacting on the Internet, for example, poses one of the main challenges in

researching CMC. Notions of participation and authenticity of tasks have been reconceptualized within CMC research. For instance, while participation in FTF studies can be simply confirmed through physical presence of the participants, participation in CMC research is complicated by the issues of participants' identity and genuine participation. Similarly, the authenticity of tasks in CMC research can be constrained by the technology and participants' unfamiliarity with the technology.

Even though researching CMC in education should be viewed in its own right, methodological comparisons to FTF research may be inevitable due to the socially driven and interdisciplinary nature of research in education. Thus, a potential challenge for those who use ethnographic approach in this field need to provide the necessary methodological rationale for using CMC tools and determines how it influences the principles and practice of data collection and data analysis. Garcia et al. (2009), however, cautioned:

Due to the continual state of transformation and development of the online environment, i.e. IM and blogs, "... ethnographers will need to be alert to such shifts as they search for topics for research, define their research setting, choose and adjust methods of data collection, and use appropriate strategies for gaining access to research settings and subjects." (p. 78).

In seeking naturalistic data in a CMC environment, the methodology must take into account the nature and degree of participation of both the researcher and the participants interacting in the technology-mediated environment. The natural elements of CMC interaction must be accompanied by the description of the interactive tools of the CMC environment and whether or how those features are fully utilized. With multiple participants interacting using various CMC tools simultaneously, research methodology must be flexible enough to make sense of the interaction.

CMC researchers who use previously established FTF methods or instruments to investigate CMC may overlook the absence or hidden social and cultural cues in the CMC environment. Since the instruments are originally meant for FTF investigation, CMC tools must be sufficiently versatile and data analysis must be holistic in order for the researcher to capture the meanings.

CMC research design that may overlook the participants' computer and technical skills as well as the atmosphere of the research site may seriously affect the research validity. The skills, atmosphere, and attitudes towards technology may pose as moderating variables and must be properly addressed at the outset of the research. This can be a problem stemming from improper sampling or insufficient training of those skills.

CMC researchers may not be conversant with CMC technology and therefore may not fully utilize both the CMC tools and its environment in the research design. This is natural since the researchers are education practitioners or professionals who may not be technologically savvy. Or the research task could very well be delegated to the technical professionals or administrators who are without strong conceptual framework with minimal help from education practitioners or professionals. This challenge, however, can be overcome if educational researchers collaborate closely

with technical professionals when planning the research design. The potential negative effects of the CMC environment on CMC research participants have been one of the main issues in data collection. For example, participants disappear from CMC interaction because they lose interest in the interaction, quitting due to the overwhelming nature of CMC technology, or sometimes disruptiveness or playfulness during the interaction (through flaming, spamming, etc.). To maintain desirable participation, researchers may need to ensure that tasks given are manageable and interesting, and voluntary participation would lead to a degree of self-fulfillment.

---

## Future Directions

The CMC environment, due to its versatility and flexibility, will continue to be a popular research site where CMC researchers or mere enthusiasts will take advantage of its convenient features, produce original research, or replicate existing traditional FTF research. Consequently, future directions for researching CMC in education may need to: (1) assert an active role of the researcher (for example, through participant observation), and (2) utilize the popular and emerging CMC research sites (SNS, game-based learning, and virtual reality worlds and VLE).

Future research may wish to impose various degrees of involvement or increased role of the researcher while on the online medium in order to ensure sufficient interaction and produce desirable outcomes. Kakh (2014), for instance, played an active role of a mentor to ensure the full process of writing on Google Docs would take place. Auto-ethnography (Clark and Gruba 2010) is another approach that calls for a full participation of the researcher in the setting. Similarly, research on online learning will demand for active participation of the researcher. There is a need to continue addressing, for instance, teacher absence in online courses through the notion of teaching presence. Deris et al. (2012) maintained that in ensuring such presence in online courses “careful planning of a course, and effective discourse facilitation and direct instruction, with emphasis on teacher’s personal presence, are fundamental in making presence felt in the online classroom” (p. 266). However, such participation requires both the researcher’s willingness to work with others and skills in establishing rapport with the participants. Hence, the increased role of the researcher seems to be the future trend of CMC research as researchers get more involved by “virtually” being present in the online community or the social network sites under investigation.

CMC research in language and education have started venturing into the virtual reality worlds, VLE, and or communities that have been rapidly growing on the Internet as well as game-based learning. Sadler and Dooly (2013), for example, examine *Second Life*, a virtual reality world for language learning. In recent years, teachers and educators have started experimenting with game-based learning such as SimCity EDU (Farber 2013). Others explored the medium to develop STEM skills (Science, Technology, Engineering, Mathematics) (Lodaya 2013). These virtual worlds and game-based learning environments could be fertile grounds for CMC researchers to challenge themselves and perhaps bring CMC research to a new level systematically examining these highly synchronized interactions or through



“gamifying ... of the classroom” (Farber 2013, p. 1) and following Sadler and Dooly’s (2013) suggestion that future research should be on how these environments could be used for language learning. In discussing educators and teachers’ use of online platforms for teacher professional development, Kabilan et al. (2011) adds that “future research should also focus on the use of these popular online platforms as tools that educators can utilise for their online professional development projects” (p. 112).

Social network sites, such as *Livemocha*, *Busuu*, *Facebook*, etc., will attract more CMC researchers to continue to investigate, for example, the effects of the users’ social interactions and relationships on language and culture learning, academic literacy, and acquisition of skills. This is because in recent years CMC practices have expanded to the use of smartphones, tablets, and *iPads* in various social media where users socially interact with other users (and content) from wherever they are through the use of blogs, wikis, instant messaging, Skype, Viber, and popular SNS as effective platforms for learning and teaching (Dooly and O’Dowd 2012; Kakh 2014; Thomas et al. 2013).

CMC researchers continue to productively work with existing and emerging technologies. These are fertile research sites which offer useful data through various innovative methodologies and research tools. Their commitment to research will continue to contribute to our understanding of language and education and the important role of technology therein.

---

## Cross-References

- ▶ [Ethnography and Language Education](#)
- ▶ [Researching Multimodality in Language and Education](#)
- ▶ [Second Language Acquisition Research Methods](#)

---

## Related Articles in the Encyclopedia of Language and Education

Carey Jewitt: [Multimodal Discourses Across the Curriculum](#). In Volume: Language and Technology

Kevin M. Leander and Cynthis Lewis: [Literacy and Internet Technologies](#). In Volume: Literacies and Language Education

Mat Schulze: [Complexity Approaches to Intelligent Computer-Assisted Language Learning \(ICALL\)](#). In Volume: Language and Technology

---

## References

- Aydin, Z., & Yildiz, S. (2014). Using Wikis to promote collaborative EFL writing. *Language Learning & Technology*, 18(1), 160–180. Retrieved from <http://llt.msu.edu/issues/february2014/aydinyildiz.pdf>

- Batson, T., & Peyton, J. K. (1986). ENFI Project Report 1985–1986, Unpublished manuscript available from the ENFI Project, Gallaudet University, Washington, DC.
- Benbunan-Fich, R., & Hiltz, S. R. (1999). Impacts of asynchronous learning networks on individual and group problem solving. *Group Decision and Negotiation*, 8, 409–426.
- Berge, Z. L., & Collins, M. P. (1995). *Computer-mediated communications and the online classroom*. Cresskill: Hampton Press.
- Bruce, B. C., Peyton, J. K., & Batson, T. (1993). *Network-based classrooms: Promises and realities*. Melbourne: Cambridge University Press.
- Cheng, R. (2010). Computer-mediated scaffolding in L2 students' Academic Literacy Development. *CALICO Journal*, 28(1), 74–98.
- Chun, D. M. (1994). Using computer networking to facilitate the acquisition of interactive competence. *System*, 22(1), 17–31.
- Clark, C., & Gruba, P. (2010). The use of social networking sites for foreign language learning: An autoethnographic study of Livemocha. In C. Steel, M. Keppell, P. Gerbic, & S. Housego (Eds.), *Curriculum technology transformation for an unknown future. Proceedings ascilite Sydney 2010* (pp. 164–173). Sydney, Australia.: The University of Queensland.
- Deris, F. D., Zakaria, M. H., & Mansor, W. F. A. W. (2012). Teaching presence in online course for part-time undergraduates. *Procedia – Social and Behavioral Sciences*, 66, 255–266. doi:10.1016/j.sbspro.2012.11.268.
- Dooly, M., & Hauck, M. (2012). Researching multimodal communicative competence in video and audio telecollaborative encounters. In M. Dooly & R. O'Dowd (Eds.), *Researching online foreign language interaction and exchange: Theories, methods and challenges* (pp. 135–162). Oxford: Peter Lang.
- Dooly, M., & O'Dowd, R. (Eds.). (2012). *Researching online foreign language interaction and exchange: Theories, methods and challenges*. Oxford: Peter Lang.
- Farber, M. (2013). Game-based learning in practice. Retrieved from <http://www.edutopia.org/blog/game-based-learning-in-practice-matthew-farber>
- Garcia, A. C., Standlee, A. I., Bechhoff, J., & Cui, Y. (2009). Ethnographic approaches to the internet and computer-mediated communication. *Journal of Contemporary Ethnography*, 38(1), 52–84. doi:10.1177/0891241607310839.
- Hanna, B. E., & de Nooy, J. (2009). *Learning language and culture via public internet discussion forums*. New York: Palgrave Macmillan.
- Harasim, L. M. (1990). *Online education: Perspectives on a new environment*. New York: Praeger Publishers.
- Harrison, R. (2013). Profiles in social networking sites for language learning- Livemocha revisited. In M.-N. Lamy & K. Zourou (Eds.), *Social networking for language education* (pp. 100–116). New York: Palgrave Macmillan.
- Hawkes, R. (2009). Digital technology as a tool for active learning in MFL: Engaging language learners in and beyond the secondary classroom. In M. Evans (Ed.), *Foreign language learning with digital technology* (pp. 80–103). London: Continuum Books.
- Herring, S. C. (Ed.). (1996). *Computer-mediated communication: Linguistic, social, and cross-cultural perspectives*. Philadelphia: John Benjamins Publishing.
- Hurtado, I. G., & Llamas, J. M. C. (2014). Social networks in university classrooms: An experience of teaching and learning with pre-service teachers through Facebook. *Online Pedagogy and Course Design*, 4(3). doi:10.4018/ijopcd.2014070103.
- Kabilan, M. K., WanMansor, W. F. A., & Embi, M A. (2011). Online collaboration of English language teachers for meaningful professional development experiences. *English Teaching: Practice and Critique*, 10(4), 94–115. Retrieved from <http://education.waikato.ac.nz/research/files/etpc/files/2011v10n4art6.pdf>
- Kabilan, M. K., Wei, K. T., & Widodo, H. P. (2012). ICT and ELT in South East Asia: Identifying the research agenda and practices. In M. K. Kabilan, K. T. Wei, & H. P. Widodo (Eds.), *ICT and*

- ELT: Research and practices in South East Asia* (pp. xi–xviii). Penang: Universiti Sains Malaysia Publishers.
- Kakh, S. Y. (2014). *Developing non-native postgraduate students' academic writing skills in English using Google Docs*. Johor Bahru: Universiti Teknologi Malaysia.
- Kern, R. (1995). Restructuring classroom interaction with networked computers: Effects on quantity and characteristics of language production. *The Modern Language Journal*, 79(4), 457–476.
- Kerr, E. B., & Hiltz, S. R. (1982). *Computer-mediated communication system: Status and evaluation*. New York: Academic.
- Litchfield, A., Dyson, L. E., & Lawrence, E. (2007). Directions for m-learning research to enhance active learning. In R. Atkinson, C. McBeath, S. K. A. Soong, & C. Cheers (Eds.), *ICT: Providing choices for learners and learning. Proceedings ascilite Singapore 2007* (pp. 587–596). Singapore: Centre for Educational Development, Nanyang Technological University.
- Lodaya, H. (2013). More than just play: game-based learning environments are powerful tools for STEM. Retrieved from <http://stemwire.org/2013/07/15/more-than-just-play-game-based-learning-environments-are-powerful-tools-for-stem/>
- Loncar, M., Barrett, N. E., & Liu, G.-Z. (2014). Towards the refinement of forum and asynchronous online discussion in educational contexts worldwide: Trends and investigative approaches within a dominant research paradigm. *Computers & Education*, 73(10), 93–110.
- Looi, C.-K., Seow, P., Zhang, B., So, H.-J., Chen, W., & Wong, L.-H. (2010). Leveraging mobile technology for sustainable seamless learning: A research agenda. *British Journal of Educational Technology*, 41(2), 154–169. doi:10.1111/j.1467-8535.2008.00912.x.
- Mollering, M., & Levy, M. (2012). Intercultural competence in computer-mediated-communication: An analysis of research methods. In M. Dooly & R. O'Dowd (Eds.), *Researching online foreign language interaction and exchange: Theories, methods and challenges* (pp. 233–265). Oxford: Peter Lang.
- Panichi, L., & Deutschmann, M. (2012). Language learning in virtual worlds: Research issues and methods. In M. Dooly & R. O'Dowd (Eds.), *Researching online foreign language interaction and exchange: Theories, methods and challenges* (pp. 205–232). Oxford: Peter Lang.
- Park, M. (2014). *An ecological perspective on intercultural telecollaborative learning between Korean learners of English and American learners of Korean*. University of Texas at Austin. Retrieved from <http://hdl.handle.net/2152/26946>
- Rohfeld, R. W., & Hiemstra, R. (1995). Moderating discussions in the electronic classroom. In Z. L. Berge & M. P. Collins (Eds.), *Computer mediated communication and the online classroom* (pp. 91–104). Cresskill: Praeger Publishers.
- Sadler, R., & Dooly, M. (2013). Language learning in virtual worlds: Research and practice. In M. Thomas, H. Reinders, & M. Warschauer (Eds.), *Contemporary computer-assisted language learning* (pp. 159–182). London: Bloomsbury.
- Thomas, M., Reinders, H., & Warschauer, M. (Eds.). (2013). *Contemporary computer-assisted language learning*. London: Bloomsbury.
- WanMansor, W. F. A. (2012). Introduction to research in online language teaching and learning. In W. F. A. WanMansor (Ed.), *Research in online language teaching and learning* (pp. 1–6). Johor Bahru: Universiti Teknologi Malaysia Publishers.
- Ware, P., & Kessler, G. (2014). Telecollaboration in the secondary language classroom: Case study of adolescent interaction and pedagogical integration. *Computer Assisted Language Learning*. doi:10.1080/09588221.2014.961481.
- Warschauer, M. (1996). Comparing face-to-face and electronic discussion in the second language classroom. *CALICO Journal*, 13(2), 7–26.
- Whyte, S. (2014). Bridging the gaps: Using social media to develop techno-pedagogical competences in pre-service language teacher education. *Researching and Teaching Languages for Specific Purposes*, 33(2), 143–169.

- Zheng, B., Niiya, M., & Warschauer, M. (2015). Wikis and collaborative learning in higher education. *Technology, Pedagogy and Education*, 5139(July 2015), 1–18. doi:10.1080/1475939X.2014.948041.
- Zourou, K., & Loiseau, M. (2013). Bridging design and language interaction and reuse in Livemocha's Culture Section. In M.-N. Lamy & K. Zourou (Eds.), *Social networking for language education* (pp. 77–99). New York: Palgrave Macmillan.

---

# Index

## A

Acceleration of globalization, 116  
Acculturation, 221  
    model, 172  
Action ethnography, 383  
Actor network theory, 320  
'Acts of identity' model, 257  
Additive dialect model, 147  
Afrikaans, 138  
Alsace, 133  
Alternative days (AD) model, 490  
Anthropolitical linguistic approach, 275  
Arabic language, 136  
    and Jewish schools, 42  
Arizona, 131  
Arts-based approaches  
    art for scholarship's sake, 358–360  
    description, 354  
    early developments, 354–355  
    future research, 362–364  
    hybrid forms, 357–358  
    music theory and technique, 356  
    problems and difficulties in, 360–362  
Attitude Towards Japan and the West  
    Questionnaire (AJWQ), 259  
Audio-lingual method (ALM), 46  
Audio recordings, 451  
Autobiographical memory, 246  
Autobiographical notes, 178  
Autoethnography, 357, 386, 540

## B

Bahasa Meleyu policy, 45  
Baratz champions, 148  
Basque census and identity, 90  
Basque language preschool, 77  
Basque literacy, 90

Basque Street Survey, 94  
Behaviorist model, 423  
Belgian law, 89  
Big Data, 191  
Bilingual and immersion education policies, 41  
Bilingual Education program, 49  
Bilingual-intercultural education, 57  
Bilingualism and bilingual education  
    classroom code-switching, 224  
    community language education, 223  
    compound bilinguals, 216  
    coordinative bilinguals, 216  
    educational programme, 224  
    European languages programmes, 224  
    fused system hypothesis, 218  
    intellectual development, 218  
    lexical and syntactic development, 217  
    linguists and psychologists, 216  
    modern linguistics, 216  
    psycholinguistic approaches, 219–221  
    semilinguals, 219  
    sociolinguistic approaches, 221–223  
    subordinative bilinguals, 216  
Biliteracy content, 130  
Biliteracy contexts, 128  
Biliteracy development, 129  
Biliteracy media, 129  
Bioscientific model, 388  
Black Language (BL), 508, 510, 511  
Bloomington seminar, 4  
Body movements, educational interaction  
    CMC, 484  
    conversation analysis, 477, 478  
    emotion, 481  
    first language and second language  
        speakers, 479  
    joint activities and task accomplishment, 478  
    microethnography, 477

- Body movements, educational interaction (*cont.*)  
 multimodal analysis and embodied  
 interaction, 480  
 structural approach, 477
- Bolivia, 130
- British Association of Applied Linguistics  
 (BAAL), 346
- Broadcast media, 114
- C**
- Cambodian, 126
- Canada's reports of language statistics, 89
- Canadian census, 86, 88, 92
- Canadian immersion programmes, 327
- Cantonese-English bilingual programme, 489
- Carger's research methods, 412
- Carspecken's five stage approach, critical  
 ethnography, 383
- Catalytic validity, 387
- Celtic languages, 20
- Censuses  
 description, 84  
 difficulties, 92–93  
 early, 85  
 ideologies and politics, 88–90  
 language questions, 87–88  
 role of, 85  
 in United States, 85
- Cherokee Nation, 131
- Child's home language variety, 68
- Chinese, 132
- Chinese as Second Language (CSL), 484
- Chomskyan approach, 197
- Chomskyan model, 74
- Civil rights organizations, 506
- Classroom activity, 149
- Classroom-based social research (CBSR), 258
- Classroom code-switching, 224  
 academic discourses and literacies, 498  
 AD model, 490  
 bilingual classroom strategies, 498  
 critical research paradigms, 491  
 critical social theory, 491  
 CT model, 490  
 curriculum genre, 497  
 definition, 488  
 design-interventionist studies, 495–497  
 disciplinary pluralinguals, lack of, 496  
 EFL vocabulary acquisition, 494  
 first language (L1) and second language  
 (L2) use, 489–490  
 focus-on-form, 495
- French-as-a-foreign-language classrooms,  
 491  
 ideational functions, 492  
 interpersonal functions, 492  
 interpretive research paradigms, 491  
 IRF, 493  
 longitudinal research, 497  
 micro ethnographic studies, 492  
 multimodality, 498  
 quantitative and functional coding  
 analysis, 489  
 research designs, 496–497  
 students' vocabulary learning, 494  
 textual functions, 492  
 theory-driven research questions, 496
- Classroom discourse and student learning,  
 interactional approaches  
 audio recordings, 451  
 CLIL, 455  
 data collection, 459  
 EMCA, 453–454  
 ethnographic design, 451  
 IRE, 452  
 language-learning tasks, 453  
 SCT, 452, 453  
 SLA, 452  
 technological limitations, 457–458  
 video recording, 451, 459
- Classroom interactional competence (CIC), 467
- Classroom literacy, 442
- Code-mixing, 488
- Code-switching, 333–334, 508
- Coding system, 451
- Cognitive psychology, 87, 243, 519
- COLE project, 209
- Coloniality, 416
- Communicative orientation of language  
 teaching (COLT), 423
- Communicative repertoires, 126, 134, 135
- Competition model (CM), 207
- Complementarity, 439
- Complexity theory, 374
- Compound bilinguals, 216
- Computer-assisted survey administration, 86
- Computer mediated communication (CMC)  
 data collection and data analysis, 539  
 definition, 532  
 E-Learning, 533  
 ENFI, 533  
 FTF, 534, 535, 537, 538, 540  
 hands-on approach, 538  
 intercultural telecollaborative project, 537  
 internet, 540

- in language and education, 532
  - linguistics perspective, 534
  - negative effects of, 540
  - qualitative and ethnographic methodology, 535
  - research projects, 537
  - SNS, 535
  - social media, 536, 537
  - techniques, 117
  - Concurrent translation (CT) model, 490
  - Connaissance inutile, 47
  - Constellation-of-dimensions approach, 160
  - Constructivist approach, 451
  - Content and language integrated learning (CLIL), 209, 455
    - immersion pedagogy, 329
    - learner perspectives on learning, 331
    - sociocultural and political factors, 331–332
    - teacher beliefs and practices, 329–330
    - use of ethnography, 328–329
  - Contextualization cues, 299
  - Continua of biliteracy, 126
    - diaspora and linguistic borderlands, 133–134
    - and ecology of language, 136–137
    - ethnic, immigrant and heritage languages, 132–133
    - and ethnography of LPP, 137
    - evolution, environment, and endangerment, 128
    - global spread of English, 131
    - implementational and ideological spaces, 138–139
    - indigenous language revitalization, 131–132
    - intersecting relationships, 128
    - nested relationships, 127
    - power relations, 129
    - and translanguaging, 135–136
  - Conversation analysis (CA), 299, 477, 478, 480, 494
    - applied linguistics/SLA, 465
    - conversation analytic framework, 471
    - ESL learners, 465
    - ICT, 470, 471
    - and interactional competence, 466–467
    - and language teaching, 467
    - learning opportunities, 468
    - learning over time, 469
    - NS-NNS/NNS-NNS conversations, 465
  - Convey a ‘theory’ of groupness, 90
  - Coordinative bilinguals, 216
  - Correlational study, 186
  - Critical discourse analysis, 73, 302, 303, 317
  - Critical ethnography
    - and action research/participatory action research, 386
    - Anderson’s dialogical process, 385
    - Carspecken’s five stage approach, 383
    - Conquergood’s research, 385
    - description, 382
    - in educational research, 383
    - future research, 389–390
    - issues in, 387–388
    - Madison process, 384
    - variants of, 386
  - Critical language awareness, 149
  - Critical pedagogy, 519
  - Critical race theory (CRT), 260
  - Critical social theory, 491
  - Critical studies of discourse, 302, 304
  - Critical White Studies, 261
  - Cross-cultural narrative inquiry, 411
  - Cross-linguistic influence (CLI), 198
  - Cultural criticism, 519
  - Cultural determinism, 270
  - Cultural/ethnic nationality and identity, 86
  - Cultural identity, 259
  - Culturist approach to identity, 165
  - Cummins’ linguistic interdependence hypothesis, 198
  - Cumulative-enhancement model (CEM), 199
  - Curator’s exhibitionism, 385
  - Curriculum, 232
  - Custodian’s rip off, 385
- D**
- Deficit approach, 148
  - Deficit theory, 162
  - Democratic validity, 387
  - Dialect rights position, 147
  - Diary-based identity research, 178–179
  - Diaspora, 133
  - Digital Rhetorics* study, 521
  - Digital technology, 119
  - Discourse analysis, 16, 347, 422
    - anthropological investigations of, 300–301
    - classroom-based studies, 302–303
    - contextualization cues, 299
    - definition, 298
    - interactional sociolinguists, 300
    - MDA, 304
    - MMDA, 303–304
    - narrative analysis, 301
  - Discourse analytic method, 510
  - Discourse-centered online ethnography, 119
  - Discourse ethnographic project, 397

Discursive and material oppression of U.S.-  
Mexican students, 411

*Domesday Book*, 85

Dominican, 134

Dutch National Programme, 42

Dying language, 103

Dynamic systems theory, 208, 230, 374

## E

Ecology of language, 130, 136–137

Education, 6

Educational anthropology, 55

E-Learning, 533

Electrophysiology, 208

Embodiment, 478

Enculturation, 285

Endangerment, 128

English as a foreign language (EFL), 424, 427, 455

English as a second language (ESL), 424, 427,  
465, 466, 469, 479, 490, 493

“English for the Children” initiatives, 76

English language learners (ELL), 257, 264, 510

English-language performance, 56

‘English-only’ language policies, 76

English-speaking Canada, 57

Entertainment industry, 114

Enthusiast’s infatuation, 385

Environment, 128

Epistemic search sequence (ESS), 469

Epistemic status checks (ESCs), 469

Erickson, Fredrick, 344–345

Ethics, 120

Ethnicity, 75

Ethnodrama, 358

Ethnography, 7, 176

aptitude, 7

bilingual-bicultural program, 57

bilingual education, 56

bilingual-intercultural education, 57

complex multiscale realities, 59, 62

concern with cultural interpretation, 54

contrastive insight, 58

educational anthropology, 55

emic perspective, 54

family language policy, 61

globalism, 59

ideological and implementational spaces, 57

ideological and institutional mechanisms, 56

indigenous cultural practices, 55

language endangerment, 59

language policy, 54, 137

linguistic anthropology, 55

Māori-English bilingualism, 61

methods, 425, 427, 507

monitoring, 62

multilayered contexts and processes, 55

New Language Policy Studies, 61

nondominant languages, 63

nonparticipant and participant observation, 54

phonetics, 54

policy-oriented linguistic-educational

ethnographic research, 56

problems and difficulties, 62

progressive-political commitment, 58

Quechua-language maintenance, 57

Rakaumangamanga School, 61

research, 317

sensitivity, 7

studies, 243

social constructivism, 56

sociocultural process, 54

super-diversity, 58

super-diversity and language endangerment, 59

translanguage, 60

way of seeing policy, 62

Ethnography and language education

communicative function, 271

cultural determinism, 270

ethnography of speaking, 272–274

federal regulations and funding sources, 278

language socialization, 277

language use, 277

linguistic anthropology of education,  
274–275

methodological principles, 272, 276

multi-sited ethnographic research, 275

qualitative research, 277

reciprocity, 277

recording interaction, 277

socializing function, 271

Ethnography of communication (EC), 299, 491,  
505, 506

Ethnomethodological conversation analysis  
(EMCA), 453–454

Ethnopoetics, 354

European Commission’s (EC) Eurobarometer, 91

European languages programmes, 224

Event-related potentials (ERPs), 208

Evolution, 127

Exploratory practice, 426



**F**

- Facebook, 538
- Face-to-face (FTF) conversations, 534
- Family language policy (FLP), 61, 108
- Feminist criticism, 519
- Fine-grained discourse analytic methods, 494
- Fine-grained linguistic analysis, 507
- Flickr, 522
- Focus-on-form, 495
- Ford foundation language, 44
- Formal education, 284
- Formal schooling, 68
- France, 133
- Functional coding approach, 491

**G**

- Geographic information systems (GIS)
  - technology, 94
- Geosemiotics, 395
- Globalization of English
  - description, 28
  - early developments, 29–30
  - future research, 35–36
  - grammar, 33
  - ideologies, 32–33
  - issues, 35
  - linguistic form, 30–31
  - shifting function, 31–32
  - significance, 28
- Goffman, Erving, 343–344
  - studies, 437
- Graded Intergenerational Dislocation Scale (GIDS), 104
- Guarani, 131
- Gumperz, John, 343

**H**

- Halo effect, 176
- Hawthorne effect, 176
- Hebrew, 133
- Heritage, 132–133, 229, 234
- Heterochrony, 369
- Heteroglossia, 385
- High Academy of the Quechua Language, 61
- High-point microanalysis, 249
- Home language, 42
- Hymes, Dell, 341–342
- Hypertext, 520

**I**

- Identity research
  - diaries and journals, 178–179
  - early developments and contributions, 172–174
  - ethnography, 176
  - future research, 180
  - interview, 176–177
  - narrative inquiry and analysis, 172–174
  - problems in, 180
  - questionnaires, 178
- Ideological and implementational spaces, 130, 138–139
- Ideologies of language
  - array of technologies of government, 75
  - child's home language variety, 68
  - critical discourse analysis, 73
  - discourse analysis, 71
  - early developments, 69–70
  - ethnicity, 75
  - formal schooling, 68
  - future directions, 78
  - ideology of English monolingualism, 71
  - ideology of individualism, 71
  - linguistics and educational research, 70
  - multicultural and multilingual settings, 68
  - poststructuralist/postmodern paradigms, 73
  - problems and difficulties, 76–78
  - social inequality, 70
  - standard language ideology, 72
  - syntax' paradigm, 74
  - Tanzanian socialist government, 76
- Ideology of English monolingualism, 71
- Ideology of individualism, 71
- Immersion
  - and CLIL (*see* Content and language integrated learning (CLIL))
  - code-switching and classroom language use, 333–334
  - language acquisition and development, 332
  - literacy development, 333
  - and non-immersion students, 327
- Immersion pedagogy, 329
- Immersion programs, 197
- Immigrant, 132–133
- Immigrant language learners, 260
- Indigenous language revitalization, 131–132
- Information and communication technologies (ICT), 518, 521, 522
- Information theory, 488

- Initiation-response-evaluation (IRE), 452  
 sequences, 299
- Initiation-response-feedback (IRF)  
 analytical tradition and conversation  
 analysis, 494  
 language-focus-IRF, 493  
 story-focus-IRF, 493
- Instrument reliability, 190
- Instruments for research into second language  
 learning (IRIS), 189
- Interactional competence, 466–467
- Interactional competence for teaching (ICT),  
 470, 471
- Interactional ethnography, 441
- Interactional sociolinguistic (IS), 34, 300, 491  
 approach, 343
- Intercultural Discourse Questionnaire (IDQ), 537
- International Corpus of English (ICE), 31
- Interaction analysis, 422
- International Statistical Congress, 85
- Internet, 115
- Interpretive research paradigms, 491, 492
- Interrater reliability, 190
- An Island Called Home*, 357
- Israeli law, 42
- J**
- John Dewey's theory, 358
- K**
- Korean, 132
- Kurdish, 136
- L**
- Laboratory for the Study of Interaction and  
 Discourse In Educational Research  
 (L-SIDER), 276
- Labovian approach, 114
- Language acquisition, 332
- Language awareness, 133
- Language ecology, 18
- Language education policy  
 bilingual and immersion education policies, 41  
 definitions, 40  
 Dutch National Programme, 42  
 ecological models, 41  
 future directions, 49  
 government institutions, 42  
 home language, 42  
 improvement, 45–47
- Māori language, 44, 45
- Modern Standard Arabic, 42
- monolingualism, 44
- Pacific languages, 45
- Philippines parliament, 41
- plurilingual proficiency, 44
- problems and difficulties, 48–49
- Qur'anic Arabic, 42
- research, 47
- social unit, 41
- sociolinguistic ecology, 43
- Thelot committee, 43
- UNESCO, 41
- Language Identity Awareness and Development  
 (LIAD), 264
- Language loss and revitalization  
 community & hyphen based language  
 maintenance, 102  
 cultural autonomy, 104  
 dying language, 103  
 early developments and major  
 contributions, 101–102  
 endangered languages, 103  
 ethnic identities, 108  
 ethnic revival movements, 103  
 minority language situations, 108  
 monoculturalism, 103  
 monolingualism, 103  
 multilingual repertoires and abstinence,  
 108  
 multilingual speakers, 108  
 neutral research to advocacy, 105  
 new technologies, 104–105  
 personal language ideologies, 107  
 positive language shift, 103  
 researchers and communities, 106  
 speaker's choice, 100  
 success vs. failure, 107
- Language Loyalty in the United States, 101
- Language Policy Unit of the Council of  
 Europe, 19
- Language portraits, 396
- Language, race and racism  
 biological categorizations, 505  
 Black Language, 508  
 code-switching practices, 508  
 discourse analytic methods, 510  
 ethnographic methods, 507  
 ethnography of communication, 506  
 literacy, 507  
 Native American languages, 505  
 non-European languages, 504

- participation frameworks, 507
  - participation structures, 507
  - racial and ethnic groups, 509
  - sociocultural language and literacy, 510
  - SSCs, 508
  - standard/academic forms of language, 513
  - styles of learning, 507
  - Language shift, 101
  - Language socialization
    - acquisition of language, 285
    - aspect of, 284
    - bilingual working-class community, 286
    - classroom-based interaction, 286
    - definition, 284
    - ethnographic perspective, 287–288
    - field-based collection and analysis, 287
    - formal education, 284
    - Hasidic community, 289
    - home-based and school-based practices, 290
    - longitudinal study design, 287
    - micro and macro levels of analysis, 288
    - social interactions, 284
    - sociocultural reproduction, 290
  - Language teacher research methods
    - COLT, 423
    - discourse analysis, 422
    - EFL, 424
    - ESL, 424, 425
    - ethnographic analysis, 422
    - exploratory practice, 426
    - interaction analysis, 422
    - psychometric analysis, 422
    - qualitative methods, 422
    - reconceptualization, 424, 428
    - sociocultural perspective, 428
    - teacher cognition, 424, 425
    - teacher decision-making, 424
    - TESOL, 426, 428, 429
    - think aloud (TA) study, 425
  - Language teaching, 467
  - Language variation and education
    - arguments for non-intervention, 151
    - challenges, 155
    - classroom solutions, 151–152
    - nonstandard dialects, literacy and policies, 149–150
    - sociolinguistic views and prescriptivist traditions, 151
    - teachers and teachers' attitude, 151
  - Language variation and education early developments, 151
  - Latino, 133
  - The Latin Project, 207
  - Lemke's theory of timescales, 368
  - Life Language Restoration Workshop, 106
  - Limpopo, 138
  - Linguistic anthropology, 55
  - Linguistic borderlands, 134
  - Linguistic ethnography
    - BAAL, 346
    - emergence and development of, 340
    - Erickson, Fredrick, 344–345
    - Goffman, Erving, 343–344
    - Gumperz, John, 343
    - Hymes, Dell, 341–342
    - interdisciplinary agenda, 346–347
    - LEF, 346
    - post-modernity, 347–348
  - Linguistic Ethnography Forum (LEF), 346
  - Linguistic legitimacy, 29
  - Linguistic profiling, 16
  - Linguistic repertoires, 513
  - Literacy
    - education and narrative (*see* Narrative)
    - socio-cultural communities, 243
  - Local area network (LAN), 533
  - The Logic of Nonstandard English, 69
- M**
- Madison's model, 384
  - Maori language, 44
  - Material culture, 319
  - Maya, 131
  - Media research, 116, 120
  - Mediated discourse analysis (MDA), 304
  - Metalinguistic awareness, 228
  - Mexico, 137
  - Microanalysis of interethnic counseling
    - interviews, 439
  - Microdevelopment approach, 375
  - Microethnography, 344, 477
    - context analysis, 436
    - contributions, 437–441
    - description, 436
    - digital audio and video technology, 443
    - ethnography of communication, 437
    - future research, 445
    - interactional sociolinguistics, 437
    - literacy practices, 442
    - social interaction, 441
    - studies, 302
  - Micropolitics, 344

- Minority languages, 101  
 Modern language aptitude test (MLAT), 210  
 Modern Standard Arabic, 42  
 Māori, 131  
     English bilingualism, 61  
     language, 45  
 Morpheme order study, 184  
 Mother tongue, 88  
 Multi-competence, 230  
 Multicultural identities, 261  
 Multicultural London English, 164  
 Multilingual internet, 117  
 Multilingual language acquisition  
     cognitive and psychopedagogic approaches, 209  
     contributions, 199–208  
     definition, 196  
     early developments, 197–199  
     event-related potentials, 208  
     future research, 211  
     problems in, 209–211  
     study/stay abroad language acquisition, 209  
 Multilingualism, 114, 116, 118, 121  
 Multimodal analysis, 480, 482  
 “Multimodal discourse analysis (MMDA)”, 303–304  
 Multimodality, 440, 498  
     aesthetic perspectives, 319  
     design literacies, digital literacies and visual literacies, 320  
     emotions and embodiment, 318  
     ethnographic research, 317  
     immersive and virtual worlds perspectives, 319–320  
     material cultural perspectives, 319  
     mobility perspectives, 320  
     modes and non-linear representation, 321  
     multiple modes and equity research, 316  
     pedagogy of multiliteracies, 315–316  
     social semiotics, 313–314  
     translingual perspectives, 319  
     transmediation, 315  
 Music theory and technique, 356
- N**
- Narrative, 261  
     abilities and features, 249  
     analysis, 301  
     assessment procedures, 249  
     assessment profile, 249  
     basic skills, 244  
     children’s socio-cognitive skills, 248  
     cognitive psychology, 243  
     cross-sectional and longitudinal studies, 244  
     definition, 242  
     ethnography of communication approach, 243  
     individual, linguistic and cultural variations, 244–245  
     linguistic approach, 243  
     multiculturalism, 410  
     narrative-based interventions, 250  
     oral narrative, 242  
     predictive value of, 246–247  
     socialization, 243  
     written narrative, 242  
 Narrative inquiry  
     autoethnographic perspective, 414  
     Carger’s research methods, 412  
     cross-cultural, 411  
     definition, 408  
     early developments, 409–410  
     future research, 416–417  
     key features, 408  
     from Latin America, 413  
     multicultural education, 410  
     problems in, 415–416  
 Native North American languages, 55  
 Navajo Reading Study, 41  
 Netherlands, 136  
 NetSpeak, 121  
 New Delhi, 131  
 New Language Policy Studies, 61  
 New London Group, 315–316, 322  
 New York City, 134  
 New Zealand, 131  
 No Child Left Behind Act, 130  
 Non-Hasidim, 289  
 Nonstigmatized standard dialect, 147  
 Novelty, 361
- P**
- Pacific Islands, 131  
 Pacific languages, 45  
 Pakistan, 137  
 Pan Africa Media Research Organization (PAMRO), 91  
 Participant structure, 489  
 Pedagogical practice, 228, 229, 234  
 Peer teaching, 440  
 Performance ethnography, 386  
 Personal language ideologies, 107  
 Personal narratives, 246  
 Peru, 132  
 Pew Center Hispanic Trends Project, 91

- Philippines parliament, 41  
 Positive language shift, 103  
 Post-modernity, 347–348  
 Pragmatics, 199  
 Prestigious and immigrant bilingualism, 133  
 Prestigious bilingual education, 133  
 Preventive linguistics, 105  
 Probability theory, 86  
 Process validity, 387  
 Progressive-political commitment, 58  
 Psycholinguistic approaches, 219–221  
 Psychometric analysis, 422  
 Puerto Rican, 126
- Q**  
 Québec, 131  
 Quechua, 131  
 Quechua-language maintenance, 57  
 Questionnaires, 178  
*Quipus*, 85  
 Qur’anic Arabic, 42
- R**  
 Racialization, 512  
 Radical contextualism, 444  
 Rakaumangamanga School, 61  
 Reading road, 151  
 Reciprocity, 439  
 Recognition and redistribution, 165  
 Reformed linguistics, 105  
 Refugee, 130, 133  
 Reliability, 190  
 Replicability, 190  
 Research approaches  
   computer-mediated peer review, 520  
   critical and post-structuralist perspectives, 520  
   ethnographic study, 521  
   evidence-based research, 525  
   internet, 520, 527  
   participant-observation and interview, 519  
   participatory action research, 524  
   semi-structured interviews, 522  
   social networking and remixing, 522  
   technology-mediated communication  
     practices, 527  
   word processing, 519  
   written composition, 518  
 Responsible linguistics, 105  
 Restricted code, 162  
 Russian, 137
- S**  
 Saami language, 78  
 SALA-project, 209  
 Sampling theory, 86  
 Scale jumping, 376  
 Schol-ARTists, 358  
 School language, 70  
 Science, technology, engineering and math  
   (STEM), 247  
 Scotland, 132  
 “Seal of Bilingualism”, 76  
 Second language acquisition (SLA), 184, 256,  
   452, 465  
   acts of identity, 257  
   attitude and motivation, 259  
   CBSR, 258  
   composition studies, 261  
   CRT and Critical White Studies, 261  
   diasporic communities, 262  
   interdisciplinary approach, 263  
   IRIS, 189  
   morpheme order study, 184  
   motivation in language learning, 258  
   problems in, 189–191  
   qualitative research, 187–188  
   quantitative research, 185–187  
   race and ethnicity, 260  
   translanguaging and moment analysis, 262  
 Second language (L2) learners, 259  
 Self-portrait, 400  
 Semilingual(s), 219  
 Semilingualism, 219  
 Semi-structured conversation (SSC), 508  
 Sepedi, 138  
 Singapore language policy, 44  
 Skeptic’s cop-out, 385  
 SLA and identity. *See* Second language  
   acquisition (SLA)  
 Slovak-Hungarian bilingual program, 77  
 Sámi, 132  
 Sámi language shift, 102  
 Social class, language education research  
   communicative activity of London  
     secondary school students, 164  
   constellation-of-dimensions approach, 160  
   early developments, 161–164  
   Eckert’s research, 164  
   problems in, 165–167  
   Rampton’s work, 164  
 Social identity, 258  
 Social learning, 523  
 Socially realistic linguistics, 55  
 Social media, 118

- Social network sites (SNS), 535, 541
- Social problems, 5
- Social realism, 20
- Social semiotics, 313–318
- Societal language conflict, 18
- Sociocultural and political factors, 331–332
- Sociocultural studies, 483
- Sociocultural theory (SCT), 452, 453, 458
- Sociolinguistic(s), 4, 509, 512
  - approaches, 221–223
  - ecologies, 60
  - phenomena, 16
- Sociology of language, 118
  - analysis of variance, 9
  - Bloomington seminar, 4
  - connections to education, 6
  - contributions, 5
  - key research approaches, 7–9
  - social problems, 5
  - verstehende research to rescue, 10–12
  - verstehende versus erklärende sciences, 10–12
- Sociology of language and education (SLE)
  - challenges and problems, 21–22
  - contributions, 19–21
  - deficit model, 17
  - educational institutions, 16
  - “emancipatory” approach, 18
  - future research, 22
  - language conflict research, 18
  - language ecology, 18
  - language-related issues and phenomena, 18
  - language use and language attitudes, 17
  - medium-of-instruction, 17
  - post-colonial societies, 16
  - sociolinguistic phenomena, 16
- South Africa, 130
- South African Advertising Research Foundation (SAARF), 91
- South American Andes, 131
- Spatio-temporal visualisations, 400
- Standard language ideology, 72
- Stanza analysis, 249
- Stephanie Springgay, 359
- Story grammar analysis, 249
- Structural approach, 477
- Structuralism, 271
- Study/stay abroad language acquisition, 209
- Stylisation, 164
- Subordinative bilinguals, 216
- Surveys
  - carried out at, 84
  - categories, 84
  - description, 84
  - difficulties in, 92–93
  - European Commission residents, 91
  - history of, 85
  - household, 91
  - on language knowledge, 87–88
  - Manchester Statistical Society, 85
  - methodology, 86–87
- Swedish classrooms, 136
- T**
- Tanzanian socialist government, 76
- Teachers of English to Speakers of Other Languages (TESOL), 426, 428, 429
- Teacher’s reception of language variation, 153
- Technological changes, 229
- Technological determinism, 525
- Thelot committee, 43
- Theory of linguistic relativity, 354
- Theory-of-mind (ToM), 248
- Think aloud (TA) study, 425
- Three main message systems, 162
- Timescales
  - definition, 368
  - ecosocial systems, 368
  - in education research, 368–370
  - future research, 376
  - problems and difficulties in, 368–370
  - and social identification, 370–373
- Tollefson’s historical-structural approach to language policy, 31
- Traditional sociolinguistic approaches, 117
- Translanguaging, 60, 134–136, 261, 488
  - cognitive processing, 229
  - creativity and criticality, 232
  - definition, 231
  - metacognitive and metalinguistic awareness, 228
  - pedagogical practice, 228, 229, 234
  - student-to-student interactions, 235
  - trans-disciplinary consequences, 233
  - trans-formative nature, 233
  - trans-system and trans-spaces, 233
  - in Welsh classroom, 229
- Translation, 95
- Trans-media digital literacy, 526
- Transmediation, 315
- Transnational schooling, 137
- Trilingual and quadrilingual language programmes, 19

Turkish, 136  
Typological primacy model (TPM), 199

**U**

Ukrainian, 137  
UNESCO, 41  
Urdu, 136, 137  
US law, 42  
U.S. southwest, 134

**V**

Validity, 189  
Video recording, 451, 459  
Vienna-Oxford International Corpus of English  
(VOICE), 31  
Virtual ethnographies, 524  
Visual language diary, 400  
Visual methods, in language research  
  designing language, 395–396  
  development, 395–396

  future research, 403  
  looking at language, 399–401  
  seeing language, 399–401  
Vygotskian theory, 244

**W**

Web 2.0, 118  
Weinreich's typology, 217  
Welsh, 134  
Welsh laws, 42  
White Prestige Ideology (WPI), 259  
Word processing, 519

**X**

Xhosa, 138

**Z**

Zone of proximal development (ZPD), 468